

AT Commands Interface Guide for AT x41

Revision : **005**
Date : **29th September 2004**
Reference : **WM_ASW_OAT_UGD_010**

29th September 2004

Overview

The aim of this document is to provide WAVECOM customers with a full description of the AT commands associated with AT software release X41c and upper until further notice.

29th September 2004

Trademarks

®, WAVECOM®, WISMO®, MUSE Platform®, and certain other trademarks and logos appearing on this document, are filed or registered trademarks of Wavecom S.A. in France or in other countries. All other company and/or product names mentioned may be filed or registered trademarks of their respective owners.

29th September 2004

Document History

Revision	Date	History of the evolution	
001	16 Sep 2003	Creation from AT Commands Interface Guide rev 11, adaptation for X41 AT software. Updates, Creation of an Abbreviation table	
002	6 Nov 2003	Add SPI bus table for P51xx module, various corrections	
003	3 Dec 2003	Minor corrections: +WBHV execution conditions, autocharging process for P51xx modules,	
004	7 jun 2004	Additional minor corrections: line setting, operator names update, integration of X41a and X41b specific documents	
005	29 Sep 2004	+CSSD evolution Minor enhancements for Phonebook commands (CPBR, CPBW, CPBS, CPBF)	

Contents

1	INTRODUCTION	15
1.1	Scope of this document.....	15
1.2	Related documents.....	15
1.3	Abbreviations and Definitions.....	16
1.4	Presentation rules	17
2	AT COMMANDS FEATURES	19
2.1	Wavecom line settings	19
2.2	Command line	19
2.3	Information responses and result codes	19
3	GENERAL BEHAVIORS	20
3.1	SIM Insertion, SIM Removal.....	20
3.2	Background initialization	21
3.3	Length of phone numbers	22
4	GENERAL COMMANDS	23
4.1	Manufacturer identification +CGMI	23
4.2	Request model identification +CGMM.....	24
4.3	Request revision identification +CGMR	25
4.4	Product Serial Number +CGSN.....	25
4.5	Select TE character set +CSCS	27
4.6	Wavecom Phonebook Character Set +WPCS.....	28
4.7	Request IMSI +CIMI	29
4.8	Card Identification +CCID	30
4.9	Capabilities list +GCAP.....	30
4.10	Repeat last command A/	32
4.11	Power off +CPOF.....	32
4.12	Set phone functionality +CFUN	33
4.13	Phone activity status +CPAS.....	35
4.14	Report Mobile Equipment errors +CMEE	36

29th September 2004

4.15	Keypad control +CKPD	37
4.16	Clock Management +CCLK.....	38
4.17	Alarm Management +CALA	39
4.18	Ring Melody Playback +CRMP	41
4.19	Ringer Sound Level +CRSL.....	43
4.20	Generic Sim Access : +CSIM.....	44
4.21	Restricted SIM access +CRSM	47
5	CALL CONTROL COMMANDS	50
5.1	Dial command D.....	50
5.2	Hang-Up command H.....	53
5.3	Answer a call A.....	54
5.4	Remote disconnection	54
5.5	Extended error report +CEER.....	55
5.6	DTMF signals +VTD, +VTS	56
5.7	Redial last telephone number ATDL.....	57
5.8	Automatic dialing with DTR AT%Dn	59
5.9	Automatic answer ATSO	60
5.10	Incoming Call Bearer +CICB	61
5.11	Single Numbering Scheme +CSNS.....	63
5.12	Gain control +VGR, +VGT.....	64
5.13	Microphone Mute Control +CMUT	67
5.14	Speaker & Microphone selection +SPEAKER	68
5.15	Echo Cancellation +ECHO	69
5.16	SideTone modification +SIDET	74
5.17	Initialize Voice Parameters +VIP	75
6	NETWORK SERVICE COMMANDS	76
6.1	Signal Quality +CSQ.....	76
6.2	Operator selection +COPS	77
6.3	Network registration +CREG	80
6.4	Read operator name +WOPN	82
6.5	Selection of Preferred PLMN list +CPLS.....	84
6.6	Preferred operator list +CPOL.....	85
6.7	Read operator name +COPN	89

29th September 2004

7	SECURITY COMMANDS	90
7.1	Enter PIN +CPIN	90
7.2	Enter PIN2 +CPIN2	92
7.3	PIN remaining attempt number +CPINC	95
7.4	Facility lock +CLCK	96
7.5	Change password +CPWD	100
8	PHONEBOOK COMMANDS	102
8.1	Select phonebook memory storage +CPBS	102
8.2	Read phonebook entries +CPBR	104
8.3	Find phonebook entries +CPBF	106
8.4	Write phonebook entry +CPBW	107
8.5	Phonebook phone search +CPBP	110
8.6	Move action in phonebook +CPBN	111
8.7	Subscriber number +CNUM	114
8.8	Avoid phonebook init +WAIP	116
8.9	Delete Calls Phonebook +WDCP	117
8.10	Set Voice Mail Number +CSVM	118
9	SHORT MESSAGES COMMANDS	119
9.1	Parameters definition	119
9.2	Select message service +CSMS	120
9.3	New Message Acknowledgement +CNMA	121
9.4	Preferred Message Storage +CPMS	125
9.5	Preferred Message Format +CMGF	126
9.6	Save Settings +CSAS	129
9.7	Restore settings +CRES	129
9.8	Show text mode parameters +CSDH	130
9.9	New message indication +CNMI	131
9.10	Read message +CMGR	134
9.11	List message +CMGL	136
9.12	Send message +CMGS	138
9.13	Write Message to Memory +CMGW	140
9.14	Send Message From Storage +CMSS	141
9.15	Set Text Mode Parameters +CSMP	143
9.16	Delete message +CMGD	145

29th September 2004

9.17	Service center address +CSCA	146
9.18	Select Cell Broadcast Message Types +CSCB	147
9.19	Cell Broadcast Message Identifiers +WCBM	149
9.20	Message status modification +WMSC	150
9.21	Message overwriting +WMGO.....	151
9.22	Un-change SMS Status +WUSS.....	153
9.23	More Messages to Send +CMMS	154
10	SUPPLEMENTARY SERVICES COMMANDS	156
10.1	Call forwarding +CCFC.....	156
10.2	Call barring +CLCK.....	158
10.3	Modify SS password +CPWD.....	159
10.4	Call waiting +CCWA.....	160
10.5	Calling line identification restriction +CLIR.....	162
10.6	Calling line identification presentation +CLIP.....	162
10.7	Connected line identification presentation +COLP	164
10.8	Advice of charge +CAOC.....	165
10.9	Accumulated call meter +CACM	166
10.10	Accumulated call meter maximum +CAMM.....	168
10.11	Price per unit and currency table +CPUC.....	168
10.12	Call related supplementary services +CHLD	170
10.13	List current calls +CLCC	171
10.14	Supplementary service notifications +CSSN.....	173
10.15	Unstructured supplementary service data +CUSD.....	174
10.16	Closed user group +CCUG.....	176
11	DATA COMMANDS	177
11.1	Using AT Commands during a data connection.....	177
11.2	Bearer type selection +CBST	177
11.3	Select mode +FCLASS.....	179
11.4	Service reporting control +CR.....	180
11.5	Cellular result codes +CRC	181
11.6	DTE-DCE local rate reporting +ILRR.....	182
11.7	Radio link protocol parameters +CRLP.....	183
11.8	Others radio link parameters +DOPT	184
11.9	Select data compression %C.....	185

29th September 2004

11.10 V42 bis data compression +DS	186
11.11 V42 bis data compression report +DR	187
11.12 Select data error correcting mode \N	188
12 FAX COMMANDS	189
12.1 Transmit speed +FTM	189
12.2 Receive speed +FRM	190
12.3 HDLC transmit speed +FTH	190
12.4 HDLC receive speed +FRH	191
12.5 Stop transmission and wait +FTS	191
12.6 Receive silence +FRS	192
12.7 Setting up the PC fax application:	192
13 FAX CLASS 2 COMMANDS	193
13.1 Transmit Data +FDT	193
13.2 Receive Data +FDR	193
13.3 Transmit page punctuation +FET	194
13.4 Page transfer status parameters +FPTS	194
13.5 Terminate Session +FK	195
13.6 Page transfer bit order +FBOR	195
13.7 Buffer size report +FBUF	196
13.8 Copy quality checking +FCQ	196
13.9 Capability to receive +FCR	197
13.10 Current sessions parameters +FDIS	198
13.11 DCE capabilities parameters +FDCC	201
13.12 Local ID string +FLID	202
13.13 Page transfer timeout parameter +FPHCTO	202
13.14 Fax Class 2 indication messages	203
14 V24-V25 COMMANDS	205
14.1 Fixed DTE rate +IPR	205
14.2 DTE-DCE character framing +ICF	207
14.3 DTE-DCE local flow control +IFC	208
14.4 Set DCD signal &C	209
14.5 Set DTR signal &D	210
14.6 Set DSR signal &S	211

29th September 2004

14.7	Back to online mode O	211
14.8	Result code suppression Q.....	212
14.9	DCE response format V	213
14.10	Default configuration Z.....	213
14.11	Save configuration &W	214
14.12	Auto-tests &T.....	214
14.13	Echo E 215	
14.14	Restore factory settings &F	216
14.15	Display configuration &V.....	216
14.16	Request identification information I	218
14.17	Data / Commands Multiplexing +WMUX.....	219
15	SPECIFIC AT COMMANDS	220
15.1	Cell environment description +CCED	220
15.2	General Indications +WIND	223
15.3	Analog digital converters measurements +ADC	229
15.4	Mobile Equipment event reporting +CMER.....	230
15.5	Indicator control +CIND.....	233
15.6	Mobile equipment control mode +CMEC.....	234
15.7	Read Language Preference +WLPR	236
15.8	Write Language Preference +WLPW.....	237
15.9	Read GPIO value +WIOR	238
15.10	Write GPIO value +WIOW	238
15.11	Input/Output Management +WIOM.....	240
15.12	Abort command +WAC.....	242
15.13	Play tone +WTONE	243
15.14	Play DTMF tone +WDTMF	245
15.15	Wavecom Downloading +WDWL.....	246
15.16	Wavecom Voice Rate +WVR.....	247
15.17	Wavecom Data Rate +WDR.....	249
15.18	Hardware Version +WHWV	251
15.19	Date of Production +WDOP.....	252
15.20	Wavecom Select Voice Gain +WSVG	252
15.21	Wavecom Status Request +WSTR	254
15.22	Wavecom Scan +WSCAN	255
15.23	Wavecom Ring Indicator Mode +WRIM	256

29th September 2004

15.24 Wavecom 32kHz Power down Mode +W32K.....	257
15.25 Wavecom Change Default Melody +WCDM	258
15.26 Wavecom Software version +WSSW	259
15.27 Wavecom Custom Character Set +WCCS.....	260
15.28 Wavecom LoCK +WLCK	262
15.29 CPHS command: +CPHS.....	263
15.30 Unsolicited result : Wavecom Voice Mail Indicator : +WVMI	267
15.31 Unsolicited result : Wavecom diverted call indicator: +WDCI.....	268
15.32 Wavecom network operator name: +WNON	269
15.33 Wavecom CPHS information: +WCPI	271
15.34 Wavecom customer service profile: +WCSP	272
15.35 Wavecom Battery Charge Management +WBCM.....	273
15.36 Unsolicited result : Wavecom Battery Charge Indication +WBCI.....	277
15.37 Features Management +WFM.....	279
15.38 Commercial Features Management +WCFM	283
15.39 Wavecom Customer storage mirror +WMIR.....	284
15.40 Wavecom Change Default Player +WCDP	285
15.41 Wavecom CPHS Mail Box Number: +WMBN	286
15.42 Wavecom Alternate Line Service: +WALS	287
15.43 Wavecom Open AT control command +WOPEN	289
15.44 Wavecom Reset +WRST	291
15.45 Set Standard Tone +WSST.....	292
15.46 Wavecom Location +WLOC.....	293
15.47 Wavecom Bus Read +WBR	296
15.48 Wavecom Bus Write +WBW	298
15.49 Wavecom Bus Management +WBM	299
15.50 Wavecom Hang-up +WATH.....	305
15.51 Write IMEI +WIMEI	306
15.52 Write IMEI SVN: +WSVN.....	308
15.53 Wavecom multi-band selection command: +WMBS	309
15.54 Module Serial Number +WMSN	311
15.55 Cellular Text telephone Modem +WCTM.....	311
15.56 Modem Behaviour Configuration +WBHV	312
15.57 Hardware Configuration AT+WHCNF	315
16 SIM TOOLKIT	317

29th September 2004

16.1	Overview of SIM Application ToolKit	317
16.2	Messages exchanged during a SIM ToolKit operation.	319
16.3	SIM TOOLKIT COMMANDS.....	320
17	GPRS COMMANDS	338
17.1	Define PDP Context +CGDCONT	338
17.2	Quality of Service Profile (Requested) +CGQREQ	340
17.3	Quality of Service Profile (Minimum acceptable) +CGQMIN.....	345
17.4	GPRS attach or detach +CGATT	347
17.5	PDP context activate or deactivate +CGACT	348
17.6	Enter data state +CGDATA.....	349
17.7	GPRS mobile station class +CGCLASS	351
17.8	Select service for MO SMS messages +CGSMS	353
17.9	GPRS event reporting +CGEREP	355
17.10	GPRS network registration status +CGREG	358
17.11	Request GPRS IP service 'D'	359
17.12	Network requested PDP context activation.....	360
17.13	Automatic response to a network request for PDP context activation +CGAUTO	361
17.14	Manual response to a network request for PDP context activation +CGANS	363
17.15	Show PDP address +CGPADDR	365
17.16	Cellular result codes +CRC	366
17.17	Service reporting control +CR.....	367
17.18	Extended error report +CEER.....	368
17.19	GPRS parameters customization: +WGPRS.....	369
17.20	Full AT GPRS commands examples.....	373
18	OTHER AT COMMANDS	375
18.1	V.25 ter recommendation	375
18.2	GSM 07.05 recommendation	375
18.3	GSM 07.07 recommendation	375
19	APPENDIXES	376
19.1	ME error result code : +CME ERROR: <error>	376
19.2	Message service failure result code: +CMS ERROR : <er>	377
19.3	Specific error result codes	378

29th September 2004

19.4	Failure Cause from GSM 04.08 recommendation (+CEER).....	380
19.5	Specific Failure Cause for +CEER.....	381
19.6	GSM 04.11 Annex E-2: Mobile originating SM-transfer.....	382
19.7	Unsolicited result codes	384
19.8	Final result codes	385
19.9	Intermediate result codes	386
19.10	Parameters storage	386
19.11	GSM sequences list.....	391
19.12	Operator names.....	395
19.13	Data / Commands multiplexing protocol.....	413
19.14	CPHS Information field	416
19.15	CSP constants.....	417
20	APPENDIX A (INFORMATIVE)	421
20.1	Examples with the PIN required	421
20.2	Examples where a voice call is originated.....	422
20.3	Example with incoming calls.....	422
20.4	Example of a call forwarding	423
20.5	Example of a multiparty call	423
20.6	Examples about phonebooks.....	424
20.7	Examples about short messages	427
20.8	Examples about Fax class 2	427
20.9	+CSIM and +CRSM Examples.....	429
21	APPENDIX B: SUPPORT OF SIM TOOLKIT BY THE M.E.	432
22	APPENDIX C: STRUCTURE OF TERMINAL PROFILE	434
23	APPENDIX D: COMMAND TYPE AND NEXT ACTION INDICATOR.	439
24	APPENDIX E: CODING OF ALPHA FIELDS IN THE SIM FOR UCS2	440
25	APPENDIX F: SPECIFICATION OF POWER DOWN CONTROL VIA RS232 442	
26	APPENDIX G: CONDITIONS FOR COMMAND EXECUTION AND DEPENDENCE TO SIM	444

29th September 2004

26.1	General commands	444
26.2	Call Control commands	445
26.3	Network service commands	445
26.4	Security commands.....	446
26.5	Phonebook commands	446
26.6	Short Messages commands	446
26.7	Supplementary Services commands.....	447
26.8	Data commands.....	448
26.9	Fax commands.....	448
26.10	Class 2 Commands	448
26.11	V24-V25 commands.....	449
26.12	Specific AT commands.....	450
26.13	SIM Toolkit commands.....	451
26.14	GPRS commands	451
27	APPENDIX H: INTEROPERABILITY COMMANDS ALWAYS REPLY OK	453
28	ALPHABETICAL INDEX FOR AT COMMANDS AND RESPONSES	454

1 Introduction

1.1 Scope of this document

This document describes the AT-command based messages exchanged between an application and the WAVECOM products in order to manage GSM related events or services.

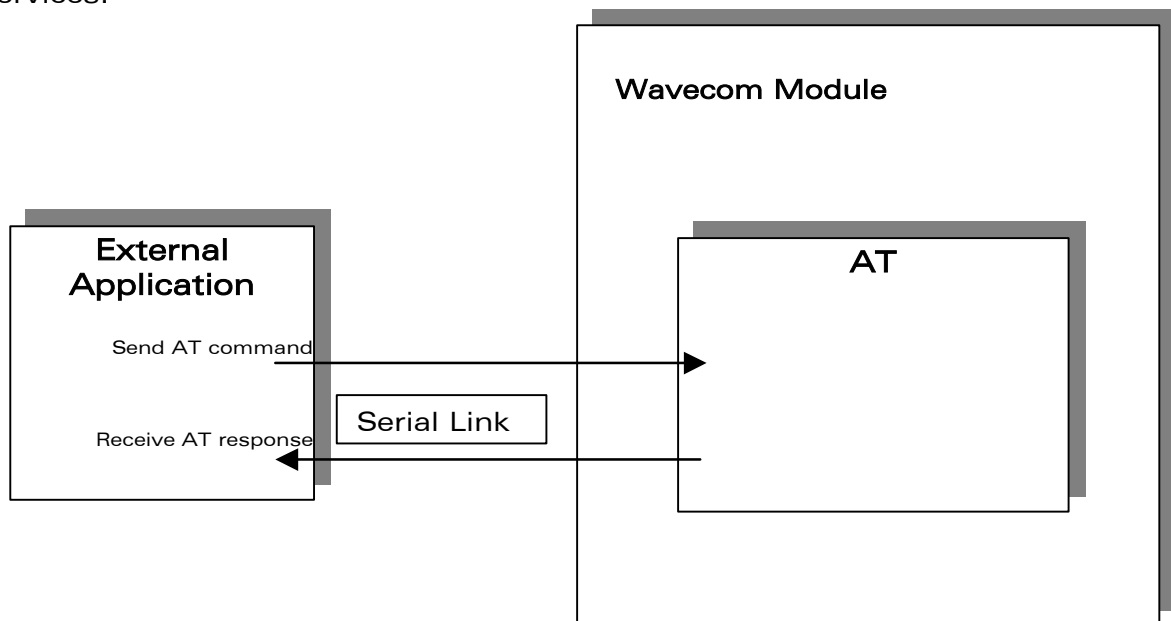

1.2 Related documents

This interface specification is based on the following recommendations:

[1] ETSI GSM 07.05: Digital cellular telecommunications system (Phase 2); Use of DTE-DCE interface for Short Message Service (SMS) and Cell Broadcast Service (CBS)

[2] ETSI GSM 07.07: Digital cellular telecommunications system (Phase 2); AT command set for GSM Mobile Equipment (ME)

[3] ITU-T Recommendation V.25 ter: Serial asynchronous automatic dialing and control

[4] ETSI GSM 03.40: Digital cellular telecommunications system (Phase 2); Technical implementation of the Short Message Service (SMS) Point-to-Point (PP)

[5] ETSI GSM 03.38: Digital cellular telecommunications system (Phase 2); Alphabets and language-specific information

29th September 2004

[6] ETSI GSM 04.80: Digital cellular telecommunications system (Phase 2): Mobile radio interface layer 3, Supplementary service specification, Formats and coding

[6] 3GPP 05.02: 3^d Generation Partnership Project ; Technical Specification Group GSM/EDGE- Radio Access Network ; Multiplexing and multiple access on the radio path - 3GPP TS 05.02 V6.9.2 (2001-04)

1.3 Abbreviations and Definitions

1.3.1 Abbreviations

ADN	Abbreviated Dialing Number (Phonebook)
AMR	Adaptative Multi-Rate
AMR-FR	AMR Full Rate (full rate speech version 3)
AMR-HR	AMR Half Rate (half rate speech version 3)
AOC	Advice Of Charge
ASCII	Standard characters table (1 byte coding)
AT	Modem Hayes commands prefix (for "ATtention")
BCCH	Broadcast Channel
BER	Bit Error Rate
CLI	Client Line Identification
CSD	(GSM data call)
CTS	Clear To Send signal
CUG	Closed User Group
DTMF	Dual Tone Multi-Frequency
DTR	Data Terminal Ready
EEPROM	Electrically Erasable Programming Only Memory
EFR	Enhanced Full Rate (full rate speech version 2)
E-ONS	Enhanced Operator Name Service
FDN	Fixed Dialing Number (Phonebook)
FR	Full Rate (full rate speech version 1)
GPRS	General Packet Radio Service
GSM	Global System for Mobile communication
HR	Half Rate (half rate speech version 1)
IMEI	International Mobile Equipment Identity
IMSI	International Mobile Subscriber Identity

29th September 2004

MCC	Mobile Country Code
ME	Mobile Equipment
MNC	Mobile Network Code
MOC	Mobile Originated Call (outgoing call)
MS	Mobile Station
MTC	Mobile Terminated Call (incoming call)
NITZ	Network Information and Time Zone
OPL	Operator PLMN List
PC	Personal Computer
PIN	Personal Identification Number
PLMN	Public Land Mobile Networks
PNN	PLMN Network Name
PPP	Point-to-Point Protocol
PSTN	Public Switched Telephone Network
PUK	PIN Unlock Key
RSSI	Received Signal Strength Indication
RTS	Ready To Send signal
SIM	Subscriber Information Module
SMS	Short Message Service
SPN	Service Provider Name
UCS2	Characters table (2 bytes coding)

1.3.2 Definitions

The words, "Mobile Station" (MS) or "Mobile Equipment" (ME) are used for mobile terminals supporting GSM services.

A call from a GSM mobile station to the PSTN is called a "mobile originated call" (MOC) or "outgoing call", and a call from a fixed network to a GSM mobile station is called a "mobile terminated call" (MTC) or "incoming call".

In this document, the word "product" refers to any Wavecom product supporting the AT commands interface.

1.4 Presentation rules

In the following, the AT commands are presented with as much precision as possible, through three paragraphs. A "Description" paragraph provides

29th September 2004

general information on the AT command (or response) behaviour. A "Syntax" paragraph describes the way to use it, the possible answers, through a readable format. A "Defined values" paragraph provides parameters values, as well for the AT command as for the corresponding responses.

Schemas are provided where necessary.

2 AT commands features

2.1 Wavecom line settings

A serial link handler is set with the following default values (factory settings):

- speed according to customer choice at order time,
- 8 bits data,
- 1 stop bit,
- no parity,
- RTS/CTS flow control.

Please use the +IPR, +IFC and +ICF commands to change these settings.

2.2 Command line

Commands always start with AT (which means ATtention) and finish with a <CR> character.

2.3 Information responses and result codes

Responses start and end with <CR><LF> (except for the ATV0 DCE response format) and the ATQ1 (result code suppression) commands.

- If command syntax is incorrect, the "ERROR" string is returned,.
- If command syntax is correct but transmitted with wrong parameters, the +CME ERROR: <Err> or +CMS ERROR: <SmsErr> strings is returned with adequate error codes if CMEE was previously set to 1. By default, CMEE is set to 0, and the error message is only "ERROR".
- If the command line has been executed successfully, an "OK" string is returned.

In some cases, such as "AT+CPIN?" or (unsolicited) incoming events, the product does not return the "OK" string as a response.

In the following examples <CR> and <CR><LF> are intentionally omitted.

3 General behaviors

3.1 SIM Insertion, SIM Removal

SIM card Insertion and Removal procedures are supported. There are software functions relying on positive reading of the hardware SIM detect pin. This pin state (open/closed) is permanently monitored.

When the SIM detect pin indicates that a card is present in the SIM connector, the product tries to set up a logical SIM session. The logical SIM session will be set up or not depending on whether the detected card is a SIM Card or not. The AT+CPIN? command delivers the following responses:

- If the SIM detect pin indicates "absent", the response to AT+CPIN? is "+CME ERROR 10" (SIM not inserted).
- If the SIM detect pin indicates "present", and the inserted card is a SIM card, the response to AT+CPIN? is "+CPIN: xxx" depending on SIM PIN state.
- If the SIM detect pin indicates "present", and the inserted card is not a SIM card, the response to AT+CPIN? is "+CME ERROR 10".
- These last two states are not provided immediately due to background initialization. Between the hardware SIM detect pin indicating "present" and the final results, the AT+CPIN? sends "+CME ERROR: 515" (Please wait, init in progress).

When the SIM detect pin indicates card absence, and if a SIM Card was previously inserted, an IMSI detach procedure is performed, all user data is removed from the product (Phonebooks, SMS etc.). The product then switches to **emergency mode**.

29th September 2004

3.2 Background initialization

After entering the PIN (Personal Identification Number), some SIM user data files are loaded into the product (phonebooks, SMS status, etc.). Please be aware that it might take some time to read a large phonebook.

The AT+CPIN? command response occurs after the PIN checking. After this response user data is loaded in background. This means that some data may not be available just when PIN entry is confirmed by 'OK'. The reading of phonebooks will then be refused by "+CME ERROR: 515" or "+CMS ERROR: 515" meaning, "Please wait, service is not available yet, init in progress".

This type of answer may be sent by the product at several points:

- when trying to execute another AT command before the previous one is completed (before response),
- when switching from ADN to FDN (or FDN to ADN) and trying to read the relevant phonebook immediately,
- when asking for +CPIN? status immediately after SIM insertion and before the product has determined if the inserted card is a valid SIM card.

29th September 2004

3.3 Length of phone numbers

Phone numbers can be made of up to 60 digits. The 20 first digits are stored in SIM, in the phonebook file (EF_{ADN} , EF_{FDN} or EF_{LND}) corresponding to the selected phonebook. The next digits are stored in other extension SIM files (EF_{EXT1} or EF_{EXT2}).

As an example:

Number of digits	Nb of records in EF_{ADN}	Nb of records in EF_{EXT1}
1 to 20	1	0
21 to 40	1	1
41 to 60	1	2

If there is no more free records in the $EF(EXT1)$, the behavior is:

- > if user tries to store an entry which number exceeds 20 digits : +CME: 20
- > if user tries to dial a number which number exceeds 20 digits : +CME: 20

As the maximum length for the numbers (in ADN, FDN, LND) phonebooks is 60 digits:

- > if user tries to dial a number which number exceeds 60 digits : +CME: 3

Before to perform a call, the number of free records in the EF_{EXT1} is checked, to be able to store the dialed number.

- > If there are free records left, the call is setup.
- > otherwise, +CME: 20 error is returned (Memory full).

Please refer to Recommendation 3GPP 11.11 for more details.

4 General commands

4.1 Manufacturer identification +CGMI

4.1.1 Description

This command gives the manufacturer identification.

4.1.2 Syntax :

Command syntax : AT+CGMI

Command	Possible responses
AT+CGMI	WAVECOM MODEM OK
<i>Note : Get manufacturer identification</i>	<i>Note : Command valid, Wavecom modem</i>

4.1.3 Defined values

No parameter

29th September 2004

4.2 Request model identification +CGMM

4.2.1 Description

This command is used to get the supported frequency bands. With multi-band products the response may be a combination of different bands.

4.2.2 Syntax

Command syntax: AT+CGMM

Command	Possible responses
AT+CGMM <i>Note : Get hardware version</i>	MULTIBAND 900E 1800 OK <i>Note : Multiband: GSM 900 MHz extended band and DCS 1800 (default configuration).</i>
AT+CGMM <i>Note : Get hardware version</i>	900E OK <i>Note: 900 Extended</i>
AT+CGMM <i>Note : Get hardware version</i>	1800 OK <i>Note : DCS</i>
AT+CGMM <i>Note : Get hardware version</i>	1900 OK <i>Note : PCS</i>
AT+CGMM <i>Note : Get hardware version</i>	G850 OK <i>Note: GSM 850</i>
AT+CGMM <i>Note : Get hardware version</i>	MULTIBAND G850 1900 OK <i>Note: Multiband: GSM 850 and PCS</i>

4.2.3 Defined values

No parameter

29th September 2004

4.3 Request revision identification +CGMR

4.3.1 Description

This command is used to get the revised software version.

4.3.2 Syntax

Command syntax : AT+CGMR

Command	Possible responses
AT+CGMR	440_09gm.Q2406A 1266500 020503 17:06
<i>Note : Get software version</i>	OK
	<i>Note : Software release 4.40, generated on the 05th of February 2003</i>

4.3.3 Defined values

No parameter

4.4 Product Serial Number +CGSN

4.4.1 Description

This command allows the user application to get the IMEI (International Mobile Equipment Identity, 15 digits number) of the product.

4.4.2 Syntax

Command syntax : AT+CGSN

Command	Possible responses
AT+CGSN	012345678901234
<i>Note : Get the IMEI</i>	OK
	<i>Note : IMEI read from EEPROM</i>
AT+CGSN	+CME ERROR: 22
<i>Note : Get the IMEI</i>	<i>Note : IMEI not found in EEPROM</i>

29th September 2004

4.4.3 Defined values

No parameter

4.5 Select TE character set +CSCS

4.5.1 Description

This command informs the ME which character set is used by the TE. The ME can convert each character of entered or displayed strings. This is used to send, read or write short messages. See also +WPCS for the phonebooks' character sets.

4.5.2 Syntax

Command syntax : AT+CSCS=<Character Set>

Command	Possible responses
AT+CSCS="GSM" <i>Note : GSM default alphabet</i>	OK <i>Note : Command valid</i>
AT+CSCS="PCCP437" <i>Note : PC character set code page 437</i>	OK <i>Note : Command valid</i>
AT+CSCS=? <i>Note : Get possible values</i>	+CSCS: ("GSM","PCCP437","CUSTOM","HEX") OK <i>Note : Possible values</i>

4.5.3 Defined values

<Character Set>

- "GSM" GSM default alphabet.
- "PCCP437" PC character set code page 437.
- "CUSTOM" User defined character set (cf. +WCCS command).
- "HEX" Hexadecimal mode. No character set used ; the user can read or write hexadecimal values.

4.6 Wavecom Phonebook Character Set +WPCS

4.6.1 Description

This **specific** command informs the ME which character set is used by the TE for the phonebooks. The ME can convert each character of entered or displayed strings. This is used to read or write phonebook entries. See also +CSCS for the short messages character sets.

4.6.2 Syntax

Command syntax : AT+WPCS=<Character Set>

Command	Possible responses
AT+WPCS="TRANSPARENT" <i>Note: Transparent mode</i>	OK <i>Note : Command valid</i>
AT+WPCS="CUSTOM" <i>Note : Custom character set</i>	OK <i>Note : Command valid</i>
AT+WPCS=? <i>Note : Get possible values</i>	+WPCS: ("TRANSPARENT","HEX","CUSTOM") OK <i>Note : Possible values</i>

4.6.3 Defined values

<Character Set>

"TRANSPARENT" Transparent mode. The strings are displayed and entered as they are stored in SIM or in ME.

"CUSTOM" User defined character set (cf. +WCCS command).

"HEX" Hexadecimal mode. No character set used ; the user can read or write hexadecimal values.

4.7 Request IMSI +CIMI

4.7.1 Description

This command is used to read and identify the IMSI (International Mobile Subscriber Identity) of the SIM card. The PIN may need to be entered before reading the IMSI.

4.7.2 Syntax

Command syntax: AT+CIMI

Command	Possible responses
AT+CIMI <i>Note : Read the IMSI</i>	208200120320598 OK <i>Note : IMSI value (15 digits), starting with MCC (3 digits) / MNC (2 digits, 3 for PCS 1900)</i>

See appendix 19.12 for MCC / MNC description.

4.7.3 Defined values

No parameter

4.8 Card Identification +CCID

4.8.1 Description

This command orders the product to read the EF-CCID file on the SIM card.

4.8.2 Syntax

Command syntax : AT+CCID

Command	Possible responses
AT+CCID <i>Note : Get card ID</i>	+CCID: "123456789AB111213141" OK <i>Note : EF-CCID is present, hexadecimal format</i>
AT+CCID? <i>Note : Get current value</i>	+ CCID: "123456789AB111213141" OK <i>Note : Same result as +CCID</i>
AT+CCID= ? <i>Note : Get possible value</i>	OK <i>Note : No parameter but this command is valid</i>

4.8.3 Defined values

No parameter

If there is no EF-CCID file present on the SIM, the +CCID answer will not be sent, but the OK message will be returned.

4.9 Capabilities list +GCAP

4.9.1 Description

This command gets the complete list of capabilities.

29th September 2004

4.9.2 SyntaxCommand syntax : AT+GCAP

Command	Possible responses
AT+GCAP	+GCAP: +CGSM, +FCLASS OK
<i>Note : Get capabilities list</i>	<i>Note : Supports GSM and FAX commands</i>

4.9.3 Defined values

No parameter

4.10 Repeat last command A/

4.10.1 Description

This command repeats the previous command. Only the A/ command itself cannot be repeated.

4.10.2 Syntax

Command syntax: A/

Command	Possible responses
A/ <i>Note : Repeat last command</i>	

4.10.3 Defined values

No parameter

4.11 Power off +CPOF

4.11.1 Description

This **specific** command stops the GSM software stack as well as the hardware layer. The AT+CFUN=0 command is equivalent to +CPOF.

4.11.2 Syntax

Command syntax : AT+CPOF

Command	Possible responses
AT+CPOF <i>Note : Stop GSM stack</i>	OK <i>Note : Command valid</i>

4.11.3 Defined values

No parameter

4.12 Set phone functionality +CFUN

4.12.1 Description

This command selects the mobile station's level of functionality.

When the application wants to stop the product with a power off, or if the application wants to force the product to execute an IMSI DETACH procedure, then it must send:

AT+CFUN=0 (equivalent to AT+CPOF)

This command executes an IMSI DETACH and makes a backup copy of some internal parameters in SIM and in EEPROM. The SIM card cannot then be accessed.

If the mobile equipment is not powered off by the application after this command has been sent, a re-start command (AT+CFUN=1) will have to be issued to restart the whole GSM registration process.

If the mobile equipment is turned off after this command, then a power on will automatically restart the whole GSM process.

The AT+CFUN=1 command restarts the entire GSM stack and GSM functionality: a complete software reset is performed. All parameters are reset to their previous values if AT&W was not used.

If you write entries in the phonebook (+CPBW) and then reset the product directly (AT+CFUN=1, with no previous AT+CFUN=0 command), some entries may not be written (the SIM task does not have enough time to write entries in the SIM card).

In addition, the OK response will be sent at the last baud rate defined by the +IPR command. With the autobauding mode the response can be at a different baud rate, it is therefore preferable to save the defined baud rate with AT&W before directly sending the AT+CFUN=1 command.

29th September 2004

4.12.2 SyntaxCommand syntax : AT+CFUN=<functionality level>

Command	Possible responses
AT+CFUN? <i>Note : Ask for current functionality level</i>	+CFUN: 1 OK <i>Note : Full functionality</i>
AT+CFUN=0 <i>Note : Set minimum functionality, IMSI detach procedure</i>	OK <i>Note : Command valid</i>
AT+CFUN=1 <i>Note : Set the full functionality mode with a complete software reset</i>	OK <i>Note : Command valid</i>

4.12.3 Defined values

<functionality level>

0 : Set minimum functionality, IMSI detach procedure

1 : Set the full functionality mode with a complete software reset

4.13 Phone activity status +CPAS**4.13.1 Description**

This command returns the activity status of the mobile equipment.

4.13.2 Syntax

Command syntax: AT+CPAS

Command	Possible responses
AT+CPAS	+CPAS: <pas>
<i>Note : Current activity status</i>	OK

4.13.3 Defined values

<pas>

0 ready (allow commands from TA/TE)

1 unavailable (does not allow commands)

2 unknown

3 ringing (ringer is active)

4 call in progress

5 asleep (low functionality)

4.14 Report Mobile Equipment errors +CMEE

4.14.1 Description

This command disables or enables the use of the "+CME ERROR : <xxx>" or "+CMS ERROR :<xxx>" result code instead of simply "ERROR". See appendix 19.1 for +CME ERROR result codes description and appendix 19.2 for +CMS ERROR result codes.

4.14.2 Syntax

Command syntax : AT+CMEE=<error reporting flag>

Command	Possible responses
AT+CMEE=?	+CMEE: (0,1) OK
AT+CMEE=0 <i>Note : Disable ME error reports, use only « ERROR »</i>	OK
AT+CMEE=1 <i>Note : Enable «+CME ERROR: <xxx>» or «+CMS ERROR: <xxx>»</i>	OK
AT+CMEE?	+CMEE: 1 OK

4.14.3 Defined values

<error reporting flag>

0 : Disable ME error reports, use only « ERROR »

1 : Enable «+CME ERROR: <xxx>» or «+CMS ERROR: <xxx>»

4.15 Keypad control +CKPD

4.15.1 Description

This command emulates the ME keypad by sending each keystroke as a character in a <keys> string.

The supported GSM sequences are listed in the appendix.

If emulation fails, a +CME ERROR: <err> is returned.

If emulation succeeds, the result depends on the GSM sequence activated:

Note: In the case where the FDN phonebook is activated, the sequences concerning "call forwarding" are allowed only if the entire sequence is written in the FDN.

4.15.2 Syntax

Command syntax : AT+CKPD=<keys>

Command	Possible responses
AT+CKPD="*#21#" <i>Note : Check every call forwarding status</i>	+CCFC: 0,7
AT+CKPD="1234" <i>Note : Sequence not allowed</i>	+CME ERROR 3

4.15.3 Defined values

<keys>

Keyboard sequence : string of the following characters (0-9,*,#).

4.16 Clock Management +CCLK

4.16.1 Description

This command is used to set or get the current date and time of the ME real-time clock.

4.16.2 Syntax

Command syntax : AT+CCLK=<date and time string>

Command	Possible responses
AT+CCLK="00/06/09,17:33:00" <i>Note : set date to June 9th, 2000, and time to 5:33pm</i>	OK <i>Note : Date/Time stored</i>
AT+CCLK="00/13/13,12:00:00" <i>Note : Incorrect month entered</i>	+CME ERROR 3
AT+CCLK? <i>Note : Get current date and time</i>	+CCLK: "00/06/09,17:34:23" OK <i>Note : current date is June 9th, 2000 current time is 5:34:23 pm</i>

4.16.3 Defined values

<date and time string>

String format for date/time is: "yy/MM/dd,hh:mm:ss".

Valid years are 98 (for 1998) to 97 (for 2097). The seconds field is not mandatory. Default date/time is "98/01/01,00:00:00" (January 1st, 1998 / midnight).

4.17 Alarm Management +CALA

4.17.1 Description

This command is used to set alarms date/time in the ME.

The maximum number of alarms is 16.

Note: The date/time should be already set with AT+CCLK command before using AT+CALA.

4.17.2 Syntax

Command syntax : AT+CALA=<date and time string> (set alarm)

AT+CALA="",<index> (delete alarm)

Command	Possible responses
AT+CALA="00/06/09,07:30" <i>Note : set an alarm for June 9th, 2000 at 7:30 am</i>	OK <i>Note : Alarm stored</i>
AT+CALA="99/03/05,13:00:00" <i>Note : set an alarm for March 5th, 1999 at 1:00 pm</i>	+CME ERROR 3 <i>Note : Invalid alarm (date/time expired)</i>
AT+CALA? <i>Note : list all alarms</i>	+CALA: "00/06/08,15 :25 :00",1 +CALA: "00/06/09,07 :30 :00",2 +CALA: "00/06/10,23 :59 :00",3 <i>Note : three alarms are set (index 1, 2, 3)</i>
	+CALA: "00/06/08,15:25:00",1 <i>Note : an alarm occurs (index 1)</i>
AT+CALA="",3 <i>Note : delete alarm index 3</i>	OK <i>Note : Alarm index 3 deleted</i>
AT+CALA? <i>Note : list all alarms</i>	+CALA: "00/06/09,07:30:00",2 <i>Note : Only one alarm (index 2)</i>

4.17.3 Defined values

<date and time string>

String format for alarms : "yy/MM/dd,hh:mm:ss" (see +CCLK).

Note : Seconds are taken into account.

29th September 2004

<index>

offset in the alarm list, range 1 to 16.

4.18 Ring Melody Playback +CRMP

4.18.1 Description

This command allows a melody to be played. All melodies are manufacturer defined.

For incoming voice, data or fax calls, 10 manufacturer-defined melodies can be played back (in a loop).

For an incoming short message, 2 manufacturer-defined sounds can be played back (once). Melody #1: short beep / Melody #2: long beep.

Note:

loop melodies (for voice/data/fax call) must be stopped by a +CRMP command with the <index> field set to 0 (example: +CRMP=0,,,0). When the <volume> parameter is given, this overwrites the <sound level> value of the +CRSL command. If the <volume> parameter is not given, the <sound level> value of +CRSL is used as default value.

4.18.2 Syntax

Command syntax : AT+CRMP=<call type>[,<volume>,<type>,<index>]

Command	Possible responses
AT+CRMP=0,7,0,2 <i>Note : Play voice call melody index 2 with volume level 7.</i>	OK <i>Note : Melody Playback.</i>
AT+CRMP=0,,,0 <i>Note : Stop the melody.</i>	OK <i>Note : The melody is stopped.</i>
AT+CRMP=? <i>Note : supported parameters</i>	+CRMP: (0-3),(0-15),0,(0-11) OK

4.18.3 Defined values

<call type>

- 0 Incoming voice call
- 1 Incoming data call
- 2 Incoming fax call
- 3 Incoming short message (SMS)

<volume>

- 0 Min volume

...

29th September 2004

6 Default volume

15 Max volume

<type>

0 Manufacturer Defined (default)

<index>

0 Stop Melody Playback

1-11 Melody ID for voice/data/fax call type (default : 1)

1-2 Melody ID for short message (default : 1)

4.19 Ringer Sound Level +CRSL

4.19.1 Description

This command is used to set/get the sound level of the ringer on incoming calls. The set command changes the default <volume> value of the +CRMP command.

4.19.2 Syntax

Command syntax : AT+CRSL=<sound level>

Command	Possible responses
AT+CRSL=0 <i>Note : Set volume to Min.</i>	OK <i>Note : Current ring playing with Min. volume.</i>
AT+CRSL=15 <i>Note : Set volume to Max.</i>	OK <i>Note : Current ring playing with Max. volume.</i>
AT+CRSL? <i>Note : get current ringer sound level</i>	+CRSL: 15 OK <i>Note : Current level is 15 (max.)</i>
AT+CRSL=? <i>Note : supported parameters</i>	+CRSL: (0-15) OK

4.19.3 Defined values

<sound level>

- 0 Min volume
- 6 Default volume (default)
- 15 Max volume

29th September 2004

4.20 Generic Sim Access : +CSIM

4.20.1 Description

This command allows a direct control of the SIM by a distant application on the TE. The <command> is sent without any modification to the SIM. In the same manner the SIM <response> is sent back by the ME as it is.

The user shall then take care of processing SIM information within the frame specified by GSM as specified in GSM 11.11(or 3GPP TS 51.011).

If operation mode is not allowed by the ME, +CME ERROR: <error> is returned.

Between two successive +CSIM commands, there is no locking of the interface between the SIM and the GSM application. Since in this situation some command types and parameters can modify wrong SIM 's files , some operations, described below, are not allowed for CSIM command. However, it is possible to process them with the CRSM command.

4.20.2 Syntax

Command syntax : AT+CSIM=<length>,<command>

Command	Possible responses
AT+CSIM=<length>,<command>	+CSIM: <length>,<response> +CME ERROR: <err>
AT+CSIM?	OK
AT+CSIM=?	OK

4.20.3 Defined values

<length> : integer type

Length of the characters that are sent to TE in <command> or <response> (two times the actual length of the command or response). For command sent to TE, This value must be in the range [10 - 522], else a CME_ERROR=3 is returned.

<command> : hexadecimal type

29th September 2004

Command passed on by the MT to the SIM in the format as described in GSM 11.11 (or 3GPP TS 51.011) (hexadecimal character format; refer +CSCS)

Second Byte Value not supported:

Due to the absence of locking, a CME_ERROR=3 is returned for the following instructions (See CRSM commands):

- D6 : UPDATE BINARY
- DC : UPDATE RECORD
- 32 : INCREASE
- 44 : REHABILITATE
- 04 : INVALIDATE
- 88 : RUN GSM ALGORITHM
- 20 : VERIFY CHV
- 24 : CHANGE CHV
- 26 : DISABLE CHV
- 28 : ENABLE CHV
- 2C : UNBLOCK CHV
- FA : SLEEP
- C0 : GET RESPONSE

Second Byte Value warning:

Due to the absence of locking, the right response may not be returned for the following instructions (See CRSM commands).

- C2 : ENVELOPE
- A2 : SEEK
- A4 : SELECT

29th September 2004

Fifth Byte Value Restriction:

For the following instructions (Second Byte):

- A4 : SELECT
- 10 : TERMINAL PROFILE
- C2 : ENVELOPE
- 14 : TERMINAL RESPONSE
- A2 : SEEK

the user must make sure that the value of the fifth Byte of the instruction corresponds of the length of bytes (data starting from 6th byte) which follow it.

The value of the Fifth Byte must be equal of the value : $\langle \text{length} \rangle / 2 - 5$, else the command is not send to the SIM and CME_ERROR=3 is returned.

<error>: integer type

- 3 Wrong format or parameters of the command
- 13 SIM no response

<response> : hexadecimal type

Response to the command passed on by the SIM to the MT in the format as described in GSM 11.11 (or 3GPP TS 51.011) (hexadecimal character format; refer +CSCS)

29th September 2004

4.21 Restricted SIM access +CRSM

4.21.1 Description

By using this command instead of Generic SIM Access +CSIM TE application has easier but more limited access to the SIM database. This command transmits to the MT the SIM <command> and its required parameters.

As response to the command, MT sends the actual SIM information parameters and response data. MT error result code +CME ERROR may be returned when the command cannot be passed to the SIM, but failure in the execution of the command in the SIM is reported in <sw1> and <sw2> parameters.

As for the CSIM command , there is no locking between two successive commands. The user should be aware of the precedence of the GSM application commands to the TE commands.

4.21.2 Syntax

Command syntax :
AT+CRSM=<command>[,<fileid>[,<P1>,<P2>,<P3>[,<data>]]]

Command	Possible responses
+CRSM=<command>[,<fileid>[,<P1>,<P2>,<P3>[,<data>]]]	+CRSM: <sw1>,<sw2>[,<response>] +CME ERROR: <err>
AT+CRSM?	OK
AT+CRSM=?	OK

4.21.3 Defined values

29th September 2004

<command> : integer type

Command passed on by the MT to the SIM; refer GSM 11.11 (or 3GPP TS 51.011) :

176 READ BINARY**178** READ RECORD**192** GET RESPONSE**242** STATUS

all other values are reserved and the command will return +CME ERROR=3

NOTE 1: The MT internally executes all commands necessary for selecting the desired file, before performing the actual command.

<fileid> : integer type

This is the identifier of a elementary datafile on SIM. Mandatory for every command except STATUS.

NOTE 2: The range of valid file identifiers depends on the actual SIM and is defined in GSM 11.11 (or 3GPP TS 51.011). Optional files may not be present at all. This value must be in the range [0 – 65535] else a CME_ERROR=3 is returned.

<P1>, <P2>, <P3> : integer type

Parameters passed on by the MT to the SIM. These parameters are mandatory for every command, except GET RESPONSE and STATUS. The values are described in GSM 11.11 (or 3GPP TS 51.011).

<data> : hexadecimal type

information which shall be written to the SIM (hexadecimal character format; refer +CSCS).

<sw1>, <sw2> : integer type

Information from the SIM about the execution of the actual command. These parameters are delivered to the TE in both cases, on successful or failed execution of the command.

29th September 2004

<response> : hexadecimal type

response of a successful completion of the command previously issued (hexadecimal character format; refer +CSCS). STATUS and GET RESPONSE return data, which gives information about the current elementary datafield. This information includes the type of file and its size (refer GSM 11.11 (or 3GPP TS 51.011)). After READ BINARY or READ RECORD command the requested data will be returned.

<error>: integer type

- 3 Wrong format or parameters of the command
- 13 SIM no response

29th September 2004

5 Call Control commands

5.1 Dial command D

5.1.1 Description

The ATD command is used to **set a voice, data or fax call**. As per GSM 02.30, the dial command also controls supplementary services.

For a **data or a fax call**, the application sends the following ASCII string to the product (the bearer must be previously selected with the +CBST command):

ATD<nb> where <nb> is the destination phone number.

Note: If a GPRS PPP session is already running, the setting of a CSD (GSM data call) is not supported.

For a **voice call**, the application sends the following ASCII string to the product: (the bearer may be selected previously, if not a default bearer is used).

ATD<nb>; where <nb> is the destination phone number.

Please note that for an **international number**, the local international prefix does not need to be set (usually 00) but does need to be replaced by the '+' character.

Example: to set up a voice call to Wavecom offices from another country, the AT command is: "**ATD+33146290800;**"

Note that some countries may have specific numbering rules for their GSM handset numbering.

Please refer to §3.3 for details on number length.

29th September 2004

The response to the ATD command is one of the following:

Verbose code	result	Numeric code (with ATVO set)	Description
OK		0	if the call succeeds, for voice call only
CONNECT <speed>		10,11,12,13,14,15	if the call succeeds, for data calls only, <speed> takes the value negotiated by the product.
BUSY		7	If the called party is already in communication
NO ANSWER		8	If no hang up is detected after a fixed network time-out
NO CARRIER		3	Call setup failed or remote user release. Use the AT+CEER command to know the failure cause

Direct dialing from a phonebook (stored in the SIM card) can be performed with the following command:

ATD> <index>; to call <index> from the selected phonebook (by the +CPBS command)

ATD> "BILL"; to call "BILL" from the selected phonebook

ATD> mem <index> (mem is "SM", "LD", "MC", "ME", "RC", "MT" or "SN", see +CPBS command) allows direct dialing from a phonebook number. Does not function with "ON" mem.

5.1.2 Syntax

Command syntax : ATD<nb><l>[;]
 ATD><mem><index><l>[;]
 ATD><mem><name><l>[;]

Command	Possible responses
AT+CPBS? <i>Note : Which phonebook is selected ?</i>	+CPBS:"SM",8,10 <i>Note : ADN phonebook is selected, 8 locations are used and 10 locations are available</i>
ATD>SM6; <i>Note : Call index 6 from ADN phonebook</i>	OK <i>Note : Call succeeds</i>

When the **FDN phonebook** has been **locked**, only numbers beginning with the digits of FDN phonebook entries can be called.

For example, if "014629" is entered in the FDN phonebook all the phone numbers beginning with these 6 digits can be called.

29th September 2004

The **CLIR supplementary service** subscription can be overridden for **this call only**.

"I" means "invocation" (restrict CLI presentation).

"i" means "suppression" (allow CLI presentation).

Control of CUG **supplementary service** information by "G" or "g" is allowed for **this call only**. The index and info values set with the +CCUG command are used.

An outgoing call attempt could be refused if the AOC service is active and credit has expired (NO CARRIER).

When trying to set up an outgoing call while there is an active call, the active call is first **put on hold**, then the call set up is carried out.

As per GSM 02.30, **GSM sequences** may be controlled using dial commands. These sequences can contain "*", "#", but ";" is forbidden.

If the sequence is not supported or fails, +CME ERROR: <err> is returned.

In the case where the FDN phonebook is activated, the sequences concerning call forwarding are allowed only if there are written in the FDN.

See paragraph 19.11 to have the list of supported sequences.

Command	Possible responses
ATD*#21# <i>Note : Check any call forwarding status</i>	+CCFC: 0,7 <i>Note : No call forwarding</i>
ATD**61*+33146290800**25# <i>Note : Register call forwarding on no reply, with no reply timer fixed at 25 s.</i>	OK <i>Note : done</i>
ATD*2# <i>Note : Bad sequence</i>	+CME ERROR 3

5.1.3 Defined values

<nb>

destination phone number

<I> (optional parameter)

"I" means "invocation" (restrict CLI presentation).

"i" means "suppression" (allow CLI presentation).

29th September 2004

<mem>

phonebook (one of "SM", "LD", "MC", "ME", "RC", "MT" or "SN"). A default value can be selected by +CPBS command.

<index>

call number at indicated offset from the phonebook selected by the +CPBS command

<name>

call number corresponding to given name from the phonebook selected by the +CPBS command

5.2 Hang-Up command H

5.2.1 Description

The ATH (or ATH0) command is used by the application to disconnect the remote user. In the case of multiple calls, all calls are released (active, on-hold and waiting calls).

The specific Wavecom ATH1 command has been appended to disconnect the current outgoing call, only in dialing or alerting state (ie. ATH1 can be used only after the ATD command, and before its terminal response (OK, NO CARRIER, ...)). It can be useful in the case of multiple calls.

5.2.2 Syntax

Command syntax: ATH<n>

Command	Possible responses
ATH <i>Note : Ask for disconnection</i>	OK <i>Note : Every call, if any, are released</i>
ATH1 <i>Note : Ask for outgoing call disconnection</i>	OK <i>Note : Outgoing call, if any, is released</i>

5.2.3 Defined values

<n>

0 : Ask for disconnection (default value)

1 : Ask for outgoing call disconnection

29th September 2004

5.3 Answer a call A

5.3.1 Description

When the product receives a call, it sets the **RingInd** signal and sends the ASCII "RING" or "+CRING: <type>" string to the application (+CRING if the cellular result code +CRC is enabled). Then it waits for the application to accept the call with the ATA command.

5.3.2 Syntax:

Command syntax: ATA

Command	Possible responses
	RING <i>Note : Incoming call</i>
ATA <i>Note : Answer to this incoming call</i>	OK <i>Note : Call accepted</i>
ATH <i>Note : Disconnect call</i>	OK <i>Note : Call disconnected</i>

5.3.3 Defined values

No parameter

5.4 Remote disconnection

This message is used by the product to inform the application that an active call has been released by the remote user.

The product sends "NO CARRIER" to the application and sets the DCD signal.

In addition, for AOC, the product can release the call if credit has expired (release cause 68 with +CEER command).

29th September 2004

5.5 Extended error report +CEER

5.5.1 Description

This command gives the cause of call release when the last call set up (originating or answering) failed.

5.5.2 Syntax

Command syntax: AT+CEER

Command	Possible responses
ATD123456789; <i>Note : Outgoing voice call</i>	NO CARRIER <i>Note : Call setup failure</i>
AT+CEER <i>Note : Ask for reason of release</i>	+CEER : Error <xxx> OK <i>Note : <xxx>is the cause information element values from GSM recommendation 04.08 or specific Call accepted</i>

For the cause information element from GSM 04.08 see chapter 18.4 or 18.5.

"NO CARRIER" indicates that the AT+CEER information is available for failure diagnosis.

5.5.3 Defined values

No parameter

5.6 DTMF signals +VTD, +VTS

5.6.1 +VTD Description

The product enables the user application to send DTMF tones over the GSM network. This command is used to define tone duration (the default value is 300ms).

5.6.2 +VTD Syntax

Command syntax : AT+VTD=<n>

Command	Possible responses
AT+VTD=6 <i>Note : To define 600 ms tone duration</i>	OK <i>Note : Command valid</i>
AT+VTD=0 <i>Note : To set the default value</i>	OK
AT+VTD? <i>Note: interrogate current tone duration</i>	+VTD : <n> OK
AT+VTD=?	+VTD : (0-255) OK

5.6.3 Defined values

<n> : tone duration

<n>*100 is the duration in ms.

If n < 4, tone duration is 300 ms; if n > 255, the value is used modulo 256. Default value is 300 ms, that is <n> = 3.

29th September 2004

5.6.4 +VTS Description

The product enables the user application to send DTMF tones over the GSM network. This command enables tones to be transmitted, only when there is an active call.

5.6.5 +VTS Syntax

Command syntax : AT+VTS=<Tone>

Command	Possible responses
AT+VTS="A"	OK <i>Note : Command valid</i>
AT+VTS="11"	+CME ERROR: 3 <i>Note : If the <Tone> is wrong</i>
AT+VTS="4"	+CME ERROR: 3 <i>Note : If there is no communication</i>
AT+VTS="1";+VTS="3";+VTS="#" OK <i>Note : send tone sequence 13#</i>	

5.6.6 Defined values

<Tone> : DTMF tone to transmit

<Tone> is in {0-9,*,#,A,B,C,D}

5.7 Redial last telephone number ATDL

5.7.1 Description

This command is used by the application to redial the last number used in the ATD command. The last number dialed is displayed followed by ";" for voice calls only

29th September 2004

5.7.2 SyntaxCommand syntax: ATDL

Command	Possible responses
ATDL <i>Note : Redial last number</i>	0146290800; OK <i>Note : Last call was a voice call. Command valid</i>

5.7.3 Defined values

No parameter

5.8 Automatic dialing with DTR AT%Dn

5.8.1 Description

This command enables and disables:

- automatic dialing of the phone number stored in the first location of the ADN or FDN phonebook,
- automatic sending of the short message (SMS) stored in the first location of the SIM.

The number is dialed when DTR OFF switches to ON.

The short message is sent when DTR OFF switches to ON.

5.8.2 Syntax

Command syntax : AT%D<n>[;]

Command	Possible responses
AT%D1; <i>Note : Activates DTR voice number dialing</i>	OK <i>Note : Command has been executed</i>
DTR is OFF DTR switches ON <i>Note : The number in the first location of the ADN is dialed automatically</i> DTR switches OFF <i>Note : The product goes on-hook</i>	OK
AT%D2 <i>Note : Activates DTR short message sending</i>	OK <i>Note : Command has been executed</i>
DTR is OFF DTR switches ON <i>Note : The first short message is sending</i>	+CMGS: x
AT%D1;	OK
DTR is OFF DTR switches ON <i>Note : no phone number in the first location in the ADN or FDN phonebook</i>	+CME ERROR: 21

29th September 2004

Command	Possible responses
AT%D2	OK
<i>DTR is OFF</i> <i>DTR switches ON</i> <i>Note : no short message in the first location of the SIM.</i>	+CMS ERROR: 321

5.8.3 Defined values

<n> (0-2) To enable or disable automatic message transmission or number dialing. Informs the product that the number is a voice number, rather than a fax or data number.

AT%D0 Disables automatic DTR number dialing / message transmission.

AT%D1; Enables automatic DTR dialing if DTR switches from OFF to ON; Dials the phone number in the first location of the ADN or FDN phonebook. **Voice call (with semi-colon).**

AT%D1 Activates automatic DTR dialing if DTR switches from OFF to ON; Dials the phone number in the first location of the ADN or FDN phonebook. **Data or Fax call (without semi-colon).**

AT%D2 Activates automatic DTR short message transmission if DTR switches from OFF to ON. Sends the short message in the first location of the SIM.

If the first location is empty.

- AT%D1 and AT%D2 commands will receive an OK response
- The DTR ON event will trigger a CME ERROR: 21 or a CMS ERROR: 321.

5.9 Automatic answer ATSO

5.9.1 Description

This S0 parameter determines and controls the product automatic answering mode.

29th September 2004

5.9.2 Syntax

Command syntax: ATSO=<value>

Command	Possible responses
ATSO=2 <i>Note : Automatic answer after 2 rings</i>	OK
ATSO? <i>Note : Current value</i>	002 OK <i>Note : always 3 characters padded with zeros</i>
ATSO=0 <i>Note : No automatic answer</i>	OK <i>Note : Command valid</i>

All others S-parameters (S6,S7,S8 ...) are not implemented.

5.9.3 Defined values

<value>

number of rings before automatic answer (3 characters padded with zeros). Range of values is 0 to 255.

5.10 Incoming Call Bearer +CICB

5.10.1 Description

This **specific** command is used to set the type of incoming calls when no incoming bearer is given (see +CSNS).

Note:

setting the +CICB command affects the current value of +CSNS.

29th September 2004

5.10.2 SyntaxCommand syntax: AT+CICB=<mode>

Command	Possible responses
AT+CICB=1 <i>Note : If no incoming bearer, force a fax call</i>	OK <i>Note : Command accepted</i>
AT+CICB=2 <i>Note : If no incoming bearer, force a voice call</i>	OK <i>Note : Command accepted</i>
AT+CICB? <i>Note : Interrogate value</i>	+CICB: 2 OK <i>Note : Default incoming bearer: voice call</i>
AT+CICB=? <i>Note : Test command</i>	+CICB: (0-2) OK <i>Note : Speech, data or fax default incoming bearer</i>

5.10.3 Defined values

<mode>

0 : Data

1 : Fax

2 : Speech

29th September 2004

5.11 Single Numbering Scheme +CSNS

5.11.1 Description

This command selects the bearer to be used when an MT single numbering scheme call is set up (see +CICB).

Note:

setting the +CSNS command affects the current value of +CICB.

5.11.2 Syntax

Command syntax: AT+CSNS

Command	Possible responses
AT+CSNS=2 <i>Note : force a fax call</i>	OK <i>Note : Command accepted</i>
AT+CSNS=0 <i>Note : force a voice call</i>	OK <i>Note : Command accepted</i>
AT+CSNS? <i>Note : Interrogate value</i>	+CSNS: 0 OK <i>Note : Default incoming bearer: voice call</i>
AT+CSNS=? <i>Note : Test command</i>	+CSNS: (0,2,4) OK <i>Note : Voice, data or fax default incoming bearer</i>

5.11.3 Defined values

<mode>

0 : Voice

2 : Fax

4 : Data

5.12 Gain control +VGR, +VGT

5.12.1 Description

This command is used by the application to tune the receive gain of the speaker and the transmit gain of the microphone.

5.12.2 Syntax

Command syntax : AT+VGR=<Rgain>
AT+VGT=<Tgain>

Command	Possible responses
AT+VGR=25	OK <i>Note : Command valid</i>
AT+VGT=45	OK <i>Note : Command valid</i>
AT+VGR? <i>Note : Interrogate value</i>	+VGR: 64 OK <i>Note : Default receive gain</i>
AT+VGR=? <i>Note : Test command</i>	+VGR: (0-255) OK <i>Note : Possible values</i>
AT+VGT? <i>Note : Interrogate value</i>	+VGT: 64 OK <i>Note : Default transmit gain</i>
AT+VGT=? <i>Note : Test command</i>	+VGT: (0-255) OK <i>Note : Possible values</i>

Note : For the AT+VGT ? command with controller 1 set, the value is the lower value of range, where as with controller 2, value correspond to the entered value with AT+VGT=xx.

29th September 2004

5.12.3 Defined values

<Rgain> : reception gain

<Tgain> : transmission gain

The application sends:

For Q24x6 and P32x6 modules

AT+VGR=<val>	for receive gain	AT+VGT=<val>	for transmit gain	AT+VGT=<val>	for transmit gain
		Controller 1	Controller 1	Controller 2	Controller 2
0 to 15	+6 db	0 to 31	+30 db	0	+0 db
16 to 31	+4 db	32 to 63	+33 db	1	+0,5 db
32 to 47	+2 db	64 to 95	+36 db	2	+1 db
48 to 63	+0 db	96 to 127	+39 db	3	+1,5 db
64 to 79	-2 db	128 to 159	+42 db
80 to 95	-4 db	160 to 191	+45 db	19	+9,5 db
96 to 111	-6 db	192 to 223	+48 db	20	+10 db
112 to 127	-8 db	224 to 255	+51 db	21	+10.5 db
128 to 143	-10 db			22	+11 db
144 to 159	-12 db			23	+11.5 db
160 to 175	-14 db			...	
176 to 191	-16 db			58	+29 db
192 to 207	-18 db			59	+29.5 db
208 to 223	-20 db			60	+30 db
224 to 255	-22 db			61	+30,5 db
				62	+31 db
			
				101	+50,5 db
				102	+51 db
				103 to 127	reserved
				128 to 242	reserved
				243	-6,5 db
				244	-6 db
				245	-5,5 db
				246	-5 db
			
				255	-0,5 db

29th September 2004

For P5186 module :

AT+VGR=<val>	For the receive gain	AT+VGT=<val> Controller 1	For the transmit gain controller 1
0 to 15	+6 db	0 to 31	+29 db
16 to 31	+3 db	32 to 63	+32 db
32 to 47	+0 db	64 to 95	+35 db
48 to 63	+0 db	96 to 127	+38 db
64 to 79	-3 db	128 to 159	+41 db
80 to 95	-6 db	160 to 191	+44 db
96 to 111	-6 db	192 to 223	+47 db
112 to 127	-9 db	224 to 255	+47 db
128 to 143	-12 db		
144 to 159	-12 db		
160 to 175	-15 db		
176 to 191	-18 db		
192 to 207	-18 db		
208 to 223	-21 db		
224 to 239	-21 db		
240 to 255	-21 db		

The gain values listed here are relative, for absolute (electrical) values please refer to the specific hardware documentation of the module used in the application.

5.13 Microphone Mute Control +CMUT

5.13.1 Description

This command is used to mute the microphone input on the product (for the active microphone set with the +SPEAKER command). This command is only allowed during a call.

5.13.2 Syntax

Command syntax: AT+CMUT=<mode>

Command	Possible responses
AT+CMUT=? <i>Note : Test command</i>	+CMUT : (0,1) OK <i>Note : Enable / disable mute</i>
AT+CMUT? <i>Note : Ask for current value</i>	+CMUT : 0 OK <i>Note : Current value is OFF</i>
AT+CMUT=1 <i>Note : Mute ON (call active)</i>	OK <i>Note : Command valid</i>
AT+CMUT? <i>Note : Ask for current value</i>	+CMUT : 1 OK <i>Note : Mute is active (call active)</i>
AT+CMUT=0 <i>Note : Mute OFF (call not active)</i>	+CME ERROR:3 <i>Note : Command not valid</i>

5.13.3 Defined values

<mode>

0 : microphone mute off (default value).

1 : microphone mute on.

5.14 Speaker & Microphone selection +SPEAKER

5.14.1 Description

This specific command is used to select the speaker and the microphone set.

5.14.2 Syntax

Command syntax : AT+SPEAKER=<ActiveSpkMic>

Command	Possible responses
AT+SPEAKER=0 <i>Note : Speaker ONE and Micro ONE</i>	OK <i>Note : Command valid</i>
AT+SPEAKER?	+SPEAKER: 0 OK <i>Note : Speaker ONE and Micro ONE are active</i>
AT+SPEAKER=?	+SPEAKER: (0,1) OK

5.14.3 Defined values

<ActiveSpkMic>

0 : SPEAKER ONE, MICRO ONE

1 : SPEAKER TWO, MICRO TWO

5.15 Echo Cancellation +ECHO

5.15.1 Description

This **specific** command is used to enable, disable or configure the Echo Cancellation functions for voice calls (in rooms, in cars, etc.).

It is necessary to tune the Microphone gain (AT+VGT) and the Speaker gain (AT+VGR) before activating the Echo Cancellation.

Note:

- You can activate/deactivate the echo cancellation during a call without resetting the product if the <Algold> parameter is not changed. But you have to use the syntax with all parameters : AT+ECHO=1,3,30,8000,256 for instance.
- To use Echo cancellation 3, the ECHO feature must be activated.

29th September 2004

5.15.2 Syntax

Command syntax:

AT+ECHO= <mode> [, <Algold> ,
<Param1> , <Param2> , <Param3> , <Param4> , <Param5> , <Param6>]

Command	Possible responses
AT+CMEE=1 <i>Note: Enables the use of result code</i>	OK
AT+SPEAKER? <i>Note : Speaker ONE and Micro ONE are active</i>	+ SPEAKER: 0 OK
AT+SIDET=0 <i>Note: Deactivate the Sidetone</i>	OK
AT+SIDET?	+SIDET: 0,0
AT+ECHO? <i>Note : Read current settings</i>	+ECHO: 0,1,0,3,10,7 OK
AT+ECHO=1,1,0,3,10,7 <i>Note : Active Echo cancellation 1 for Mic/Spk one.</i>	OK
AT+ECHO? <i>Note : Read current settings</i>	+ECHO: 1,1,0,3,10,7 OK
AT+ECHO=1,3,30,8000,256 <i>Note : Activate the Echo cancellation 3</i>	+CME ERROR: 519 <i>Note : The new algorithm will be activated after a reset of the product</i>
AT+ECHO? <i>Note : Read the Echo cancellation settings</i>	+ECHO: 3,3,30,8000,256 OK
AT+CFUN=1 <i>Note: Reset the product</i>	OK
AT+ECHO? <i>Note : Read current settings</i>	+ECHO: 1,3,30,8000,256 OK
AT+ECHO=0 <i>Note: Deactivate the Echo Cancellation</i>	OK

29th September 2004

5.15.3 Defined values:**<mode>****0** : Deactivate Echo**1** : Activate Echo

When mode = 1 is chosen, **Algold** is mandatory.

<Algold>**1** : Echo cancellation 1 (Not supported on WISMO P51x6)**3** : Echo cancellation 3Echo cancellation 1 (4 parameters) :

- The parameter **<Volout>** specifies the maximum attenuation of the switch

<Volout>**0**: 31 db (default)**1**: 29 db**2**: 27 db**3**: 25 db

...

14: 3 db**15**: 1 db

- The parameter **<Step>** specifies the attenuation step between attenuation and no attenuation.

<Step>**0**: 1 db**1**: 2 db**2**: 3 db**3**: 4 db (default)

- The **<PcmThRel>** parameter specifies the relative threshold between max and min energy information.

The allowed range is [**0 ; 31**]. (**10** by default)

29th September 2004

- The **<PcmThMax >** parameter specifies threshold of max energy information.

The allowed range is [**0 ; 31**]. (**7** by default)

29th September 2004

Echo Cancellation 3 (3 parameters) :

- **<AlgoParam>** high value leads to high echo attenuation but the full-duplex quality will be less efficient.
The allowed range is [0 ; 63]. (**30** by default)
- **<NoiseThres>** indicates the noise threshold. Low value leads to high noise attenuation. The threshold 32767 indicates no noise attenuation.
The allowed range is [0 ;32767]. (**8000** default)
- **<NmbTaps>** indicates the Number of Taps of the Adaptive Filter. The allowed range is [64 ;256]. (**256** by default)-64 taps is for short Echo-256 taps is for long Echo.

Read Command: **AT+ECHO?**

This command returns the current settings of the Echo cancellation.

Returns:

```
+ECHO: <Status>,<Algold>, <Param1>,<Param2>, <Param3>,  
<Param4>, <Param5>,<Param6>
```

The number of parameters displayed depends on the algorithym used. For Echo cancellation 1, 4 parameters are displayed, 3 parameters are displayed for Echo cancellation 3.

<Status>

- 0** Echo Deactivated.
- 1** Echo Activated for Mic/Spk one.
- 2** Echo Activated for Mic/Spk two.
- 3** Reset the product.

5.16 SideTone modification +SIDET

5.16.1 Description

This **specific** command is used to set the level of audio feedback in the speaker (microphone feedback in the speaker).

5.16.2 Syntax

Command syntax: AT+SIDET=<val1>[,<val2>]

Command	Possible responses
AT+SIDET=1,0	OK <i>Note : Command valid</i>
AT+SIDET? <i>Note : Current value</i>	+SIDET: 1,0 OK <i>Note : Command valid</i>
AT+SIDET=?	+SIDET: (0-1),(0-3) OK

5.16.3 Defined values

<val1>

0: SideTone is disabled

1: SideTone is enabled

<val2> (default value 0 will be used if this parameter is not given)

0: 0 db

1: - 6 db

2: - 12 db

3: - 18 db

5.17 Initialize Voice Parameters +VIP

5.17.1 Description

This command allows factory settings for voice parameters to be restored from EEPROM.

These voice parameters include:

- Gain control (+VGR & +VGT commands),
- Gain controller (+WSVG command),
- Microphone mute control (+CMUT command),
- Speaker & Microphone selection (+SPEAKER command),
- Echo cancellation (+ECHO command),
- Side tone modification (+SIDET command).

5.17.2 Syntax

Command syntax : AT+VIP=<n>

.Command	Possible responses
AT+VIP?	+VIP: 1 OK
AT+VIP=2 <i>Note : Syntax error</i>	+CME ERROR: 3
AT+VIP=1 <i>Note : Restore the factory settings from EEPROM</i>	OK <i>Note : The command has been executed</i>
AT+VIP=1 <i>Note : Restore the factory settings from EEPROM with the current Echo cancellation algo (different of the default algo).</i>	CME ERROR: 519 <i>Note : Reset the product to accept the new algo.</i>
AT+VIP=? <i>Note : List of supported <n>s</i>	+VIP: (1) OK

5.17.3 Defined values

<n>

1 : Restore all voice parameters

Other values are not supported.

6 Network service commands

6.1 Signal Quality +CSQ

6.1.1 Description

This command is used to ascertain the *received signal strength indication* (<rssI>) and the *channel bit error rate* (<ber>) with or without a SIM card inserted.

6.1.2 Syntax

Command syntax: AT+CSQ

Command	Possible responses
AT+CSQ	+CSQ: <rssI>,<ber> OK <i>Note : <rssI> and <ber> as defined below</i>

6.1.3 Defined values

<rssI>:

0	-113 dBm or less
1	-111 dBm
2 to 30	-109 to -53 dBm
31	-51dBm or greater
99	not known or not detectable

<ber>:

0...7	as RXQUAL values in the table GSM 05.08
99	not known or not detectable

6.2 Operator selection +COPS

6.2.1 Description

There are three possible ways of selecting an operator (PLMN):

- 1) The product is in **manual** mode. It then tries to find the operator specified by the application and if found, tries to register.
- 2) The product is in **automatic** mode. It then tries to find the home operator and if found, tries to register. If not found, the product automatically searches for another network.
- 3) The product enters into **manual/automatic** mode, and then tries to find an operator as specified by the application (as in manual mode). If this attempt fails it enters **automatic** mode. If this is successful, the operator specified by the application is selected. The mobile equipment then enters into **automatic** mode.

Note:

*The read command returns the current mode and the currently selected operator. In manual mode, this PLMN may not be the one set by the application (as it is in the search phase).
These commands are not allowed during one communication.*

6.2.2 Syntax

To force an attempt to select and register on a network, the application must send the following command:

Command syntax: AT+COPS=<mode>, [<format> [, <oper>]]

Possible responses for AT+COPS=<mode>:

OK	Network is selected with full service
+CME ERROR: 30	No network service
+CME ERROR: 32	Network not allowed – emergency calls only
+CME ERROR: 3	Not allowed during Communication
+CME ERROR: 4	Incorrect parameters
+CME ERROR: 527	Please wait, and retry your selection later
+CME ERROR: 528	Location update failure – emergency calls only
+CME ERROR: 529	Selection failure – emergency calls only

Response syntax for AT+COPS?:

+COPS: <mode> [, <format> , <oper>]

29th September 2004

Response syntax for AT+COPS=?:

+COPS: [list of supported (<stat>, long alphanumeric <oper>, short alphanumeric <oper>s, numeric <oper>) s]

Notes:

- If an incoming call occurs during a PLMN list request, the operation is aborted (**+CME ERROR: 520**) and the unsolicited RING appears.
- *If SPN (Service Provider Name) is present in the SIM, it will be returned in both long and short alphanumeric <oper> fields. The string in the "short" field will be the SPN truncated to the appropriate character number (10).*

29th September 2004

Command	Possible responses
AT+COPS? <i>Note : Ask for current PLMN</i>	+COPS: 0,2,20801 OK <i>Note : Home PLMN is France Telecom Orange</i>
AT+COPS=? <i>Note : Ask for PLMN list</i>	+COPS: (2,"F SFR","SFR","20810"), (3,"F - BOUYGUES TELECOM","BYTEL","20820"),(3,"Orange F","Orange","20801") OK <i>Note : Home PLMN is SFR, BYTEL and Orange networks have been detected</i>
AT+COPS=1,2,20810 <i>Note : Ask for registration on SFR network</i>	+CME ERROR: 32 <i>Note : Network not allowed - emergency calls only</i>
AT+COPS=1,1,23433 <i>Note : Ask for registration on UK Orange network</i>	+CME ERROR: 529 <i>Note : Selection failed - emergency calls only</i>
AT+COPS=0 <i>Note : Ask for registration on home network</i>	OK <i>Note : Succeeded</i>
AT+COPS=3,0 <i>Note : Set <format> to long alphanumeric</i>	OK
AT+COPS? <i>Note : Ask for current PLMN</i>	+COPS: 0,0,"Orange F" OK <i>Note : Home PLMN is France Telecom Orange</i>
AT+COPS=2 <i>Note : Ask for deregistration from network</i>	OK <i>Note : Succeeded</i>
AT+COPS? <i>Note : Ask for current PLMN</i>	+COPS: 2 <i>Note : ME is unregistered until <mode>=0 or 1 is selected</i>

6.2.3 Defined values

The parameters values are the following ones:

<mode>

0: automatic (default value)

1: manual

2: deregistration ; ME will be unregistered until <mode>=0 or 1 is selected.

wavecom confidential ©

Page : 79 / 460

This document is the sole and exclusive property of WAVECOM. Not to be distributed or divulged without prior written agreement. Ce document est la propriété exclusive de WAVECOM. Il ne peut être communiqué ou divulgué à des tiers sans son autorisation préalable.

29th September 2004

3: set only <format> (for read command AT+COPS?)

4: manual / automatic (<oper> shall be present), if manual selection fails, automatic mode is entered.

<format>: format of <oper> field

0: long alphanumeric format <oper>

1: short alphanumeric format <oper>

2: numeric <oper> (**default** value)

<stat>: status of <oper>

0: unknown

1: available

2: current

3: forbidden

<oper>: operator identifier (MCC/MNC in numeric format only for operator selection)

The long alphanumeric format can be up to 16 characters long (see appendix 19.12 for operator names description, field is "Name")

The short alphanumeric format can be up to 10 characters long.

6.3 Network registration +CREG

6.3.1 Description

This command is used by the application to ascertain the registration status of the product.

29th September 2004

6.3.2 Syntax

Command syntax: AT+CREG= <mode>

Response syntax: +CREG: <mode>, <stat> [,<lac>,<ci>] for AT+CREG?
Command only

Command	Possible responses
AT+CREG?	+CREG: <mode>,<stat> OK <i>Note : As defined here-above</i>
AT+CREG=0 <i>Note : Disable network registration unsolicited result code</i>	OK <i>Note : Command valid</i>
AT+CREG=1 <i>Note : Enable network registration unsolicited result code</i>	OK <i>Note : Command valid</i>
AT+CREG=2 <i>Note : Enable network registration and location information unsolicited result code</i>	OK <i>Note : Command valid</i>
AT+CREG=?	+CREG: (0-2) <i>Note : 0,1,2 <mode> values are supported</i>

6.3.3 Defined values

<mode>

0: Disable network registration unsolicited result code (**default**)

1: Enable network registration code result code +CREG : <stat>

2: Enable network registration and location information unsolicited result code +CREG: <stat>,<lac>,<ci> if there is a change of network cell.

<stat>

0: not registered, ME is not currently searching for a new operator.

1: registered, home network.

2: not registered, ME currently searching for a new operator to register to.

3: registration denied.

4: unknown.

5: registered, roaming.

<lac>: string type; two byte location area code in hexadecimal format (e.g. "00C3" equals 195 in decimal).

<ci>: string type; two byte cell ID in hexadecimal format.

29th September 2004

6.4 Read operator name +WOPN

6.4.1 Description

This specific command returns the operator name in alphanumeric format, the numeric format being given.

With E-ONS (Enhanced Operator Name Service) feature, <lac> is an optional parameter to read names from OPL/PNN sim files. If it is not entered, name will be given with current lac. Note that in limited service, current lac is set to 0.

It also permits to erase NITZ PLMN names stored in Flash memory with "AT+WOPN=3,0".

When the WISMO module receives a NITZ (Network Information and Time Zone) message with Long Name or Short Name information, an entry with registered PLMN and names in message is created in flash memory. These names will then be used with +COPS,+COPN,+WOPN commands with the priority order defined in 3GPP TS 22.101. The WISMO module supports only network names with GSM default alphabet coding scheme.

Refer to 3GPP TS 24.008 V5.3.0, 3GPP TS 23.040 v6.1.0, 3GPP TS 22.042 v5.0.0 for more information.

6.4.2 Syntax

Command syntax: AT+WOPN=<format>,<NumOper>[,<lac>]

Response syntax: +WOPN: <format>,<AlphaOper>

Command	Possible responses
AT+WOPN=? <i>Note : Test command</i>	OK
AT+WOPN=0,20801 <i>Note : Give an operator in numeric format</i>	+WOPN : 0,"Orange F" OK <i>Note : Alphanumeric answer</i>
AT+WOPN=0,99999 <i>Note : Give a wrong operator</i>	+CME ERROR: 22 <i>Note : Not found</i>
AT+WOPN=0,20801,36 <i>Note : Give an operator in numeric format for lac 36</i>	+WOPN : 0,"Orange F" OK <i>Note : Alphanumeric answer</i>
AT+WOPN=3,0 <i>Note : Erase NITZ PLMN names stored in</i>	OK

29th September 2004

<i>flash memory</i>	
---------------------	--

6.4.3 Defined values

<format> is the required format.

0: Long alphanumeric format

1: Short alphanumeric format

Note: Use <format>=3 and <NumOper>=0 to erase NITZ PLMN names list.

<NumOper> is the operator in numeric format.

<AlphaOper> is the operator in long or short alphanumeric format (see appendix 19.12 for operator names description)

<lac> is the two bytes Location Area Code to be used to get the PLMN name. If it is not entered, Current lac will be used (0 if limited service).

29th September 2004

6.5 Selection of Preferred PLMN list +CPLS

6.5.1 Description

This command is used to select one PLMN selector with access technology list in the SIM card that is used by AT+CPL command.

6.5.2 Syntax

Command syntax: AT+CPLS= <List>

Command	Possible responses
AT+CPLS? <i>Note : Ask for selection of the SIM file</i>	+CPLS: 1 OK <i>Note : EF_OPLMNwAct is selected</i>
AT+CPLS=0 <i>Note : selection of EF_PLMNwAct</i>	<i>Note : if EF_PLMNwAct is not present, EF_PLMNsel will be selected</i>
AT+CPLS=1 <i>Note : selection of EF_OPLMNwAct</i>	+CME ERROR: 3 <i>Note : EF_OPLMNwAct is not present</i>
AT+CPLS=? <i>Note : Get possible values</i>	+CPLS: (0,1,2) OK <i>Note : The 3 files with Acces technology are present and can be selected</i>
AT+CPLS=? <i>Note : Get possible values</i>	+CPLS: (0) OK <i>Note : Only EF_PLMNwAct or EF_PLMNsel can be selected</i>

29th September 2004

6.5.3 Defined values

<List>:

0: User controlled PLMN selector with access technology EF_PLMNwAct

Note: if this file is not found EF_PLMNSel will be selected

1: Operator controlled PLMN selector with access technology EF_OPLMNwAct

2: Home PLMN selector with access technology EF_HPLMNwAct

6.6 Preferred operator list +CPOL

6.6.1 Description

This command is used to edit (or update) the SIM preferred list of networks.

This list is read in the SIM file selected by the command AT+CPLS.

6.6.2 Syntax

Command syntax: AT+CPOL=

[<index>] [,<format>[,<oper>[,<GSM_AcT>,<GSMcomp_Act>,<Utran_Act>]]]

The different possibilities are:

- AT+CPOL = <index> to delete an entry.
- AT+CPOL = , <format> to set the format used by the read command (AT+CPOL?).
- AT+CPOL = , <format>, <oper> to put <oper> in the next free location.
- AT+CPOL = <index> , <format> , <oper> to write <oper> in the <format> at the <index>.
- AT+CPOL = <index>, <format>, <oper>, <GSM_AcT>, <GSMcp_Act>, <Utran_Act> to write <oper> in the <format> at the <index> precisng the acces technology (in the case of EF_PLMNwact, EF_HPLMNwact or EF_OPLMNwact is present).

Note: per default if Acces technology parameters are not given, the GSM access technology will be choosen.

The supported format are those of the +COPS command.

The length of this list is limited to 85 entries for *EF_PLMNsel*, and 51 for *EF_PLMNwAct*, *EF_OPLMNwAct*, *EF_HPLMNwAct*.

29th September 2004

Command	Possible responses
AT+CPOL? <i>Note : Ask for preferred list of networks With only EF_PLMNsel present</i>	+CPOL:1,2,26201 +CPOL: 6,2,20810 OK <i>Note : Preferred list of networks in numeric format (read in EF_PLMNsel)</i>
AT+CPOL? <i>Note : Ask for preferred list of networks With EF_PLMNwAct selected and present</i>	+CPOL:1,2,26201,1,0,0 +CPOL: 6,2,20810,1,0,0 OK <i>Note : Preferred list of networks in numeric format (read in EF_PLMNwAct) GSM acces technology selected GSM compact acces technology not selected Utran acces technology not selected</i>
AT+CPOL=,0 <i>Note : Select long alphanumeric format</i>	OK
AT+CPOL? <i>Note : Ask for preferred list of networks With only EF_PLMNsel present</i>	+CPOL: 1,0,"D1-TELEKOM" +CPOL: 6,0,"F SFR" OK <i>Note : Preferred list of networks in long alphanumeric format</i>
AT+CPOL=7,2,20801 <i>Note : Add a network to the list</i>	OK
AT+CPOL? <i>Note : Ask for preferred list of networks With only EF_PLMNsel present</i>	+CPOL: 1,0,"D1-TELEKOM" +CPOL: 6,0,"F SFR" +CPOL: 7,0,"Orange F" OK <i>Note : Preferred list of networks in long alphanumeric format</i>
AT+CPOL=7 <i>Note : Delete 7th location</i>	OK

29th September 2004

Command	Possible responses
AT+CPOL? <i>Note : Ask for preferred list of networks With only EF_PLMNsel present</i>	+CPOL: 1,0,"D1-TELEKOM" +CPOL: 6,0,"F SFR" OK <i>Note : Preferred list of networks in long alphanumeric format</i>
AT+CPOL=8,2,77777 <i>Note : Add a new network to the list With only EF_PLMNsel present</i>	OK
AT+CPOL=8,2,77777,0,0,1 <i>Note : Add a new network to the list With EF_PLMNwact present</i>	OK <i>Note: Acces technology UTRAN is selected</i>
AT+CPOL=8,2,77777 <i>Note : Add a new network to the list With EF_PLMNwact present</i>	OK <i>Note: Per default Acces technology GSM is selected</i>
AT+CPOL? <i>Note : Ask for preferred list of networks With only EF_PLMNsel present</i>	+CPOL: 1,0,"D1-TELEKOM" +CPOL: 6,0,"F SFR" +CPOL: 8,2,77777" OK <i>Note : Preferred list of networks in long alphanumeric format but 8th entry is unknown so the product edits it in the numeric format</i>
AT+CPOL=9,0,"Orange F" <i>Note : Add a new network to the list (text format)</i>	
AT+CPOL? <i>Note : Ask for preferred list of networks With only EF_PLMNsel present</i>	+CPOL: 1,0,"D1-TELEKOM" +CPOL: 6,0,"F SFR" +CPOL: 8,2,77777" +CPOL: 9,0,"Orange F" OK <i>Note : Preferred list of networks in long alphanumeric format</i>
AT+CPOL=?	+CPOL: (1-16),(0-2) OK <i>Note : The EF can accept 16 records, and supported format are 0,1 or 2.</i>

29th September 2004

6.6.3 Defined values

<index> : position of the operator record in the sim preferred operator list. Do AT+CPOL=? to get the maximum index of the selected EF.

<format> :

- 0 long alphanumeric format for <oper>
- 1 short alphanumeric format for <oper>
- 2 numeric format for <oper>

<oper> : characterstring or integer (see <format>) indicating operator identifier.

<GSM_Act> : GSM access technology

<GSMcomp_Act> : GSM compact access technology

<Utran_Act> : UTRA access technology

- 0 access technology not selected
- 1 access technology selected

6.7 Read operator name +COPN

6.7.1 Description

This command return the list of all operator names (in numeric and alphanumeric format) stored in the module.

6.7.2 Syntax

Command syntax : AT+COPN

Command response : +COPN: <NumOper>,<AlphaOper>

Command	Possible responses
AT+COPN <i>Note : Ask for preferred list of networks</i>	+COPN: 23201,"A1" +COPN: 23203,"A max." +COPN: 23207,"A tele.ring" +COPN: 23205,"one" ... OK +CME ERROR: <err>
AT+COPN=?	OK

6.7.3 Defined values

<NumOper> is the operator in numeric format.

<AlphaOper> is the operator in long alphanumeric format (see appendix 19.12 for operator names description)

7 Security commands

7.1 Enter PIN +CPIN

7.1.1 Description

This command is used to enter the ME passwords (CHV1 / CHV2 / PUK1 / PUK2, etc.), that are required before any ME functionality can be used. CHV1/CHV2 is between 4 and 8 digits long, PUK1/PUK2 is only 8 digits long.

If the user application tries to make an outgoing call before the SIM PIN code (CHV1) has been confirmed, then the product will refuse the "ATD" command with a "+CME ERROR: 11" (SIM PIN required).

The application is responsible for checking the PIN after each reset or power on – if the PIN was enabled.

7.1.2 Syntax

Command syntax: AT+CPIN=<pin>

Command	Possible responses
AT+CPIN=1234 <i>Note : Enter PIN</i>	OK <i>Note : PIN code is correct</i>
AT+CPIN=5678 <i>Note : Enter PIN</i>	+CME ERROR : 3 <i>Note : Operation not allowed, PIN previously entered</i>

After 3 unsuccessful attempts to enter the PIN (Personal Identification Number), the PUK (Personal Unblocking Key) will be required. PUK validation forces the user to enter a new PIN code as a second parameter and this will be the new PIN code if PUK validation succeeds. CHV1 is then **enabled** if PUK1 is correct. The application therefore uses this command:

AT+CPIN=<Puk>,<NewPin>

Command	Possible responses
AT+CPIN=00000000,1234 <i>Note : Enter PUK and new PIN</i>	+CME ERROR: 16 <i>Note : Incorrect PUK</i>
AT+CPIN=12345678,1234 <i>Note : Enter PUK and new PIN, 2nd attempt</i>	OK <i>Note : PUK correct, new PIN stored</i>

29th September 2004

To ascertain which code must be entered (or not), the following query command can be used:

AT+CPIN?

The possible responses are :

+CPIN: READY	<i>ME is not pending for any password</i>
+CPIN: SIM PIN	<i>CHV1 is required</i>
+CPIN: SIM PUK	<i>PUK1 is required</i>
+CPIN: SIM PIN2	<i>CHV2 is required</i>
+CPIN: SIM PUK2	<i>PUK2 is required</i>
+CPIN: PH-SIM PIN	<i>SIM lock (phone-to-SIM) is required</i>
+CPIN: PH-NET PIN	<i>Network personalisation is required</i>
+CME ERROR: <err>	<i>SIM failure (13) absent (10) etc...</i>

Please note that in this case the mobile equipment does not end its response with the OK string.

The response +CME ERROR : 13 (SIM failure) is returned after 10 unsuccessful PUK attempts. The SIM card is then out of order and must be replaced by a new one.

Example: 3 failed PIN validations + 1 successful PUK validation

AT+CPIN?	<i>Read the PIN status</i>
+CPIN: SIM PIN	<i>The product requires SIM PIN</i>
AT+CPIN=1235	<i>First attempt to enter a SIM PIN</i>
+CME ERROR: 16	<i>Wrong PIN</i>
AT+CPIN=1236	<i>Second attempt</i>
+CME ERROR: 16	<i>Wrong PIN</i>
AT+CPIN=1237	<i>Third attempt</i>
+CME ERROR: 16	<i>Wrong PIN</i>
AT+CPIN?	<i>Read PIN state</i>
+CPIN: SIM PUK	<i>The product requires PUK</i>
AT+CPIN=99999999,5678	<i>The PUK is entered, the new PIN shall be 5678</i>
OK	<i>PUK validation is OK. New Pin is 5678</i>
AT+CPIN?	<i>Read PIN state</i>
+CPIN: READY	<i>The product is ready</i>

If the user tries to do something which requires PIN2 (CHV2), the product will refuse the action with a "+CME ERROR: 17" (SIM PIN2 required). The product then waits for SIM PIN2 to be given.

29th September 2004

Of course, if SIM PIN2 is blocked, SIM PUK2 is required instead of SIM PIN2.

For example, the product needs PIN2 to write in the fixed dialing phonebook (FDN) , so if SIM PIN2 authentication has not been performed during the current session, SIM PIN2 is required

Command	Possible responses
AT+CPBS="FD" <i>Note : Choose FDN</i>	OK
AT+CPBW=5,"01290917",129,"Jacky" <i>Note : Write in FDN at location 5</i>	+CME ERROR: 17 <i>Note : SIM PIN2 is required</i>
AT+CPIN?	SIM PIN2 <i>Note : SIM PIN2 is required</i>
AT+CPIN=5678 <i>Note : Enter SIM PIN2</i>	OK
AT+CPBW=2,"01290917",129,"Jacky" <i>Note : Write in FDN at location 5</i>	OK <i>Note : Now writing in FDN is allowed</i>

Please note that the product only requests PIN2 or PUK2 once. Therefore, if they are not entered properly, the next +CPIN? command will return "+CPIN: READY".

7.1.3 Defined values

<pin> Personal Identification Number.

<puk> Personal Unblocking Key needed to change the PIN.

See above conditions of use.

7.2 Enter PIN2 +CPIN2

7.2.1 Description

This **specific** command is used to validate the PIN2 code (CHV2), or to validate the PUK2 code (UNBLOCK CHV2) and to define a new PIN2 code.

Of course, the +CPIN command allows PIN2 or PUK2 codes to be validated, but **only** when the **last command executed resulted in PIN2 authentication failure**.

PIN2 length is between 4 and 8 digits, PUK2 length is 8 digits only.

29th September 2004

7.2.2 Syntax

Command syntax : AT+CPIN2=<pin2>

Command	Possible responses
AT+CPIN2=1234 <i>Note : Enter PIN2</i>	OK <i>Note : PIN2 code is correct</i>
AT+CPIN2=5678 <i>Note : Enter PIN2</i>	+CME ERROR: 3 <i>Note : Operation not allowed, PIN2 previously entered</i>

After 3 unsuccessful attempts, PUK2 will then be required. PUK2 validation forces the user to enter a new PIN2 code as a second parameter and this will be the new PIN2 code if PUK1 validation succeeds. The application therefore uses this command:

AT+CPIN2=<puk2>,<NewPin2>

Command	Possible responses
AT+CPIN2=00000000,1234 <i>Note : Enter PUK2 and new PIN2</i>	+CME ERROR: 16 <i>Note : Incorrect Password (PUK2)</i>
AT+CPIN2=12345678,1234 <i>Note : Enter PUK2 and new PIN2, 2nd attempt</i>	OK <i>Note : PUK2 correct, new PIN2 stored</i>

To ascertain which code must be entered (or not), the following query command can be used:

AT+CPIN2?

The possible responses are

+CPIN2: READY	<i>No PIN2 is needed</i>
+CPIN2: SIM PIN2	<i>PIN2 is required</i>
+CPIN2: SIM PUK2	<i>PUK2 is required</i>
+CME ERROR: <err>	<i>Absent (10) etc...</i>

7.2.3 Defined values:

<pin2> Personal Identification Number 2.

<puk2> Personal Unblocking Key 2 needed to change the PIN2.

<Newpin2>

Note : PIN2 length is between 4 and 8 digits, PUK2 length is 8 digits only.

7.3 PIN remaining attempt number +CPINC

7.3.1 Description

This **specific** command is used to get the number of valid attempts for PIN1 (CHV1), PIN2 (CHV2), PUK1 (UNBLOCK CHV1) and PUK2 (UNBLOCK CHV2) identifiers.

7.3.2 Syntax

Command syntax: AT+CPINC

Response syntax: +CPINC: <n1>,<n2>,<k1>,<k2>

Command	Possible responses
AT+CPINC <i>Note : Get the number of attempts left</i>	+CPINC : 2,3,10,10 OK <i>Note : First CHV1 attempt was a failure</i>
AT+CPINC? <i>Note : Get current values</i>	+CPINC : 2,3,10,10 OK <i>Note : First attempt was a failure</i>
AT+CPINC=? <i>Note : Get possible values</i>	OK

7.3.3 Defined values

<n1>, <n2> are the attempts left for PIN1, PIN2 (0 = blocked, 3 max)

<k1>, <k2> are the attempts left for PUK1, PUK2 (0 = blocked, 10 max)

For this to work, the card should be present at the time of initialization, otherwise an error will be sent (+CME ERROR : 10).

7.4 Facility lock +CLCK

7.4.1 Description

This command is used by the application to lock, unlock or interrogate an ME or network facility <fac>.

Nota: Test SIM cards (with MCC=001 & MNC=01) doesn't check "PS", "PN", "PU", "PP" and "PC" locks.

7.4.2 Syntax

Command syntax: AT+CLCK= <fac>,<mode>[,<passwd>[,<class>]]

Response syntax: +CLCK: <status> [,<class1>]<CR><LF>+CLCK:
<status>,<class2> [...]]

Command	Possible responses
AT+CLCK="SC",1,1234 <i>Note : Enable PIN</i>	OK <i>Note : PIN was correct</i>
AT+CLCK? <i>Note : Read PIN status</i>	+CLCK@("PS",0),("SC",0),("FD",0),("PN",0),("PU",0),("PP",0),("PC",0) OK <i>Note : PIN is enabled, no SIM lock, no network lock, no information on Call barring</i> <i>(no longer supported in GSM 07.07)</i>
AT+CLCK="SC",0,5555 <i>Note : Disable PIN</i>	+CME ERROR: 16 <i>Note: PIN was wrong</i>
AT+CPIN=1234 <i>Note : Enter PIN</i>	OK <i>Note : PIN was good</i>
AT+CLCK=? <i>Note : Request supported facilities</i>	+CLCK: ("PS","SC","AO","OI","OX","AI","IR","AB","AC","FD","PN","PU","PP","PC") OK <i>Note : Supported facilities</i>
AT+CLCK="PN",1,12345678 <i>Note : Activate network lock</i>	OK <i>Network lock activated</i>
AR+CLCK="AO",1,1234,2 <i>Note : Activate all outgoing calls barring for data calls</i>	OK <i>Note : Call barring is activate</i>
AT+CLCK="AO",2 <i>Note : Query BAOC status</i>	+CLCK : 1,2 OK <i>Note : BAOC activate for data calls only</i>
AT+CLCK="SC",0,0000 <i>Note : Disable PIN</i>	+CME ERROR: 521 <i>Note : PIN deactivation is forbidden with this SIM card</i>

29th September 2004

7.4.3 Defined values**<fac>** : supported facilities

- "PS" : SIM lock facility with a 8 digits password.
- "SC" : PIN enabled (<mode> = 1) / disabled (<mode> = 0)
- "AO" : BAO (Barr All Outgoing Calls)
- "OI" : BOIC (Barr Outgoing International Calls)
- "OX" : BOIC-exHC (Barr Outgoing. International Calls except to Home Country)
- "AI" : BAIC (Barr All Incoming Calls)
- "IR" : BIC-Roam (Barr Inc. When Roaming outside Home Country)
- "AB" : All Barring services
- "AG" : All outGoing barring services
- "AC" : All inComing barring services
- "PN" : Network lock with a 8 digits password (NCK).
- "PU" : Network Subset lock with a 8 digits password (NSCK).
- "PP" : Service Provider lock with a 8 digits password (SPCK).
- "PC" : Corporate lock with a 8 digits password (CCK).
- "FD" : SIM Fixed Dialing Numbers (FDN) memory feature (PIN2 is required as <password>)

<mode>**0** : unlock the facility**1** : lock the facility**2** : query status**<class>****1** : Voice (telephony)**2** : Data (apply to all bearer services)**4** : Fax (facsimile services)**8** : Short Message service**7** : Voice, Data and Fax (Default value)

Any attempt to combine different classes will result in activation / deactivation / interrogation of Voice, Data and Fax.

If <class> is omitted, default value 7 will be used.

Password maximum length is given with the AT+CPWD=? Command.

wavecom confidential ©**Page : 98 / 460**

This document is the sole and exclusive property of WAVECOM. Not to be distributed or divulged without prior written agreement. Ce document est la propriété exclusive de WAVECOM. Il ne peut être communiqué ou divulgué à des tiers sans son autorisation préalable.

29th September 2004

Note: It will not possible to lock the FDN phonebook if this one is not loaded.

7.5 Change password +CPWD

7.5.1 Description

This command is used by the application to change a password (PIN, call barring, NCK, etc.). The facility values (<fac>) are the same as for the +CLCK command with a "P2" facility to manage SIM PIN2.

For the network lock ("PN"), unlocking is forbidden after 10 failed attempts to disable (unlock) the network lock with an incorrect password.

7.5.2 Syntax

Command syntax : AT+CPWD= <fac>, <oldpwd>, <newpwd>

Command	Possible responses
AT+CPWD=? <i>Note : Possible values</i>	+CPWD: ("PS",8),("SC",8),("AO",4),("OI",4),("OX",4),("AI",4),("IR",4),("AB",4),("AG",4),("AC",4),("P2",8),("FD",8),("PN",8),("PU",8),("PP",8),("PC",8) OK <i>Note : CHV1/CHV2 must be on 8 digits maximum (4 mini)</i> <i>For call barring, on 4 digits maximum</i>
AT+CPWD="SC",1234,5555 <i>Note : Change PIN</i>	OK <i>Note : PIN was correct</i>
AT+CPWD="SC",1234,5555 <i>Note : Change PIN</i>	+CME ERROR: 16 <i>Note: PIN was wrong</i>
AT+CPIN=5555 <i>Note : Enter PIN</i>	OK <i>Note : PIN was correct</i>
AT+CPWD="PN",12345678,00000000 <i>Note : Change NCK</i>	OK <i>Note : NCK changed for net lock</i>

7.5.3 Defined values

<fac> : facility

- "PS"
- "SC"
- "AO"
- "OI"
- "OX"
- "AI"
- "IR"
- "AB"
- "AG"
- "AC"
- "P2"
- "FD"
- "N"
- "U"
- "P"
- "C"

<oldpwd>, <newpwd>

On 4 or up to 8 or 16 digits according to the facility.

8 Phonebook commands

Please refer to §3.3 for details on numbers length.

8.1 Select phonebook memory storage +CPBS

8.1.1 Description

This command selects phonebook memory storage.

Note on ADN and FDN activation: when FDN has been activated with the +CLCK command, the selection of ADN phonebook is possible only if ADN status bit3 is set to 1 (EF file "readable and updatable when invalidated"). Please refer to Recommendation 3GPP 11.11 for more details.

8.1.2 Syntax

Command syntax : AT+CPBS=<pb>[,<pin2>]

Note: <pin2> can be used only for selecting "FD" phonebook.

Command	Possible responses
AT+CPBS="SM" <i>Note : Select ADN phonebook</i>	OK <i>Note : ADN phonebook is selected</i>
AT+CPBS=? <i>Note : Possible values</i>	+CPBS: ("SM","LD","MC","ON","ME","RC","MT", "SN") OK <i>Note : only "EN" phonebook is not supported with this SIM card.</i>
AT+CPBS? <i>Note : Status</i>	+CPBS : "SM",10,20 OK <i>Note: ADN phonebook selected, 10 locations used, 20 locations available</i>
AT+CPBS="FD",1234 <i>Note : Select FDN phonebook</i>	OK <i>Note : FDN phonebook is selected</i>

Selection of ADN phonebook when FDN is active is SIM dependent.

Note : Selection of "FD" phonebook with <pin2>, when <pin2> is already verified, will give error CME ERROR: 3

29th September 2004

8.1.3 Defined values

<pb> : phonebook

- "SM" : ADN (SIM phonebook)
- "FD" : FDN (SIM Fix Dialing, restricted phonebook)
- "ON" : MSISDN (SIM own numbers)
- "EN" : EN (SIM emergency number)
- "LD" : LND (combined ME and SIM last dialing phonebook)
- "MC" : MSD (ME missed calls list)
- "ME" : ME (ME phonebook)
- "MT" : MT (combined ME and SIM phonebook)
- "RC" : LIC (ME received calls list)
- "SN" :SDN (Services dialing phonebook)

<pin2> : Personal Identification Number 2.

29th September 2004

8.2 Read phonebook entries +CPBR

8.2.1 Description

This command returns phonebook entries for a range of locations from the current phonebook memory storage selected with +CPBS.

Note :

for all phonebook read commands (+CPBR, +CPBF, +CPBN, +CPBP, +CNUM), the TON/NPI MSB of each number is set to 1 (ex : a TON/NPI stored as 17 is displayed as 145).

8.2.2 Syntax

Command syntax: AT+CPBR=<first_entry>[,<last_entry>]

Response syntax:

+CPBR: <location>, <number>, <type (TON/NPI)>, <Text>

Command	Possible responses
AT+CPBR=? <i>Note : Test command</i>	+CPBR: (1-50),60,10 OK <i>Note : 50 locations (from 1 to 50), max length for phone number is 60 digits, 10 characters max for the text.</i>
AT+CPBR=12,14 <i>Note : Read entries from 12 to 14</i>	+CPBR : 12,"112",129,"Emergency" +CPBR : 13,"+331290909",145,"Fred" +CPBR : 14,"0146290808",129,"Zazi" OK <i>Note : Display locations 12,13,14 with location, number, type (TON/NPI), Text</i>
AT+CPBR=10 <i>Note : Read entry 10</i>	+CPBR :10,"0146290921",129,"Rob" OK <i>Note: Display location 10</i>
AT+CPBR=11 <i>Note : Read entry 11 (UCS2 format)</i>	+CPBR :11,"0146290921",129,"8000010002FFFF" OK <i>Note: Display location 11</i>
AT+CPBR=52 <i>Note : Read entry 52 (wrong)</i>	+CME ERROR: 21 <i>Note : Invalid index</i>

29th September 2004

8.2.3 Defined values**<first_entry>, <last_entry>**

location (or range of locations) where to read phonebook entry.

<type (TON/NPI)>

Type of address byte in integer format. Value is 145 if the dialing string (<number> response value) includes the international access code character '+', else value is 129.

29th September 2004

8.3 Find phonebook entries +CPBF

8.3.1 Description

This command returns phonebook entries with alphanumeric fields starting with a given string. The AT+CPBF= "" command can be used to display all phonebook entries sorted in alphabetical order.

This command is not allowed for "D", "C", "N" phonebooks and for the "EN" phonebook, which does not contain alphanumeric fields.

It is possible to use this command with UCS2 strings. If a wrong UCS2 format is entered, the string is considered as an ASCII string.

8.3.2 Syntax

Command syntax : AT+CPBF=<string>

Command	Possible responses
AT+CPBF=? <i>Note : Test command</i>	+CPBF: 60,10 OK <i>Note : Max length for phone number is 60 digits, 10 characters for the text.</i>
AT+CPBF="E" <i>Note : Read entries with "E"</i>	+CPBF : 12,"112",129,"Emergency" +CPBF : 15,"+331290101",145,"Eric" OK <i>Note : Display locations with text field starting with "E"</i>
AT+CPBF="H" <i>Note : Read entries with "H"</i>	+CME ERROR: 22 <i>Note: Entry not found</i>
AT+CPBF="800001FFFF" <i>Note : Read entries starting with 0001 UCS2 character</i>	+CPBF : 11,"0146290921",129,"8000010002FFFF" OK <i>Note : Display locations with text field starting with 0001 UCS2 character</i>
AT+CPBF="8045C" <i>Note : Read entries with "8045C" (ASCII format)</i>	+CME ERROR: 22 <i>Note: Entry not found. The string has a wrong UCS2 format, it is therefore considered as an ASCII string</i>

29th September 2004

8.3.3 Defined values

<string>

Searched starting string (depends on the format of data stored in the phonebooks)

8.4 Write phonebook entry +CPBW

8.4.1 Description

This command writes a phonebook entry in location number *<index>* in the current phonebook memory storage.

"RC" and "MC" phonebooks could be only erased by +CPBW. Adding field and/or modifying field is not allowed for these phonebooks.

This command is not allowed for "EN", "LD", "MC", "RC", "MT", "SN" phonebooks, which can not be written.

29th September 2004

8.4.2 Syntax

Command syntax : AT+CPBW=<index>[,<number>[,<type>[,<text>]]]

Note: <number> usage (phone number length) depends on SIM capabilities (EF_{EXT1} file availability)

Command	Possible responses
AT+CPBW=? <i>Note : Test command</i>	+CPBW: (1-50),60,(129,145),10 OK <i>Note : 50 locations, phone number = 60 digits max, TON/NPI of 129 or 145, text length = 10.</i>
AT+CPBW= 3 <i>Note : Erase location 3</i>	OK <i>Note: Location 3 erased</i>
AT+CPBW=5,"112",129,"SOS" <i>Note : Write at location 5</i>	OK <i>Note: Location 5 written</i>
AT+CPBW=5,"01290917",129,"Jacky" <i>Note : Overwrite location 5</i>	OK <i>Note : Location 5 overwritten</i>
AT+CPBW=6,"01292349",129,"8000410042" <i>Note : write location 6 (UCS2 format for the <text> field)</i>	OK <i>Note : Location 6 is written</i>
AT+CPBW=,"+33145221100",145,"SOS" <i>Note : Write at the first location available</i>	OK <i>Note : First location available is written</i>
AT+CPBW=,"0345221100",129,"SOS" <i>Note : Write at the first location available</i>	+CME ERROR: 20 <i>Note : Phonebook full</i>
AT+CPBW=57,"112",129,"WM" <i>Note : Write at location 57 (wrong)</i>	+CME ERROR: 21 <i>Note : Invalid index</i>
AT+CPBW=7,"012345678901234567890",129,"WAVE" <i>Note : Write at location 7 a phone number exceeding the limit (21 digits)</i>	+CME ERROR: 26 <i>Note : Phone number too long</i>
AT+CPBW=7,"0122334455",129,"WAVECOM TEL" <i>Note : Write at location 7 along text (11 characters)</i>	+CME ERROR: 24 <i>Note : Text too long</i>
AT+CPBW=8,"01292349",129,"80xyz" <i>Note : write location</i>	OK <i>Note : Location 8 is written. The string has a wrong UCS2 format, it is therefore considered as an ASCII string</i>

29th September 2004

When the fixed dialing phonebook (FDN) is locked, this command is not allowed. Moreover, **when the FDN is unlocked, PIN2 is required to write** in the FDN phonebook.

But if PIN2 authentication has been performed during the current session, the +CPBW command with FDN is allowed.

Command	Possible responses
AT+CPBS="FD" <i>Note : Choose FDN</i>	OK
AT+CPBW=5,"01290917",129,"Jacky" <i>Note : Write in FDN at location 5</i>	+CME ERROR: 17 <i>Note : SIM PIN2 is required</i>
AT+CPIN?	SIM PIN2 <i>Note: SIM PIN2 is required</i>
AT+CPIN=5678 <i>Note : Enter SIM PIN2</i>	OK
AT+CPBW=5,"01290917",129,"Jacky" <i>Note : Write in FDN at location 5</i>	OK <i>Note : Writing in FDN is now allowed</i>

8.4.3 Defined values:

<index> integer type value depending on the capacity of the phonebook memory.

<number> phone number in ASCII format.

<type> TON/NPI (Type of address byte in integer format).

Note: Value is 145 if the dialing string (<number> response value) includes the international access code character '+', else value is 129 (ex : a <type> value of 17 will be written as 145).

<text> string type.

Note 1:

For the <text> parameter all strings starting with "80" , "81" or "82" are considered in UCS2 format. See the APPENDIX E (Coding of Alpha fields in the SIM for UCS2).

Note 2:

The +CSCS (Select Character set) command does not affect the format for phonebook entries.

Note 3: The maximum length of the phone number will depend upon free memory available in SIM (Please refer to §3.3 for details on number length).

8.5 Phonebook phone search +CPBP

8.5.1 Description

This **specific** command orders the product to search the phonebook for an item with the same phone number as that defined in the parameter.

8.5.2 Syntax

Command syntax : AT+CPBP=<PhoneNumber>

Command	Possible responses
AT+CPBP="+331290101" <i>Note : Search entries corresponding to this phone number</i>	+CPBP : 15,"+331290101",145,"Eric" OK <i>Note : Display the entry corresponding to the specified phone number</i>
AT+CPBP="+331290101" <i>Note : Search entries corresponding to this phone number</i>	+CPBP : 15,"01290101",129,"Eric" OK <i>Note : Display the entry corresponding to the specified phone number</i>
AT+CPBP="01290202" <i>Note : Search entries corresponding to this phone number</i>	+CPBP : 15,"+331290202",145,"David" OK <i>Note : Display the entry corresponding to the specified phone number</i>
AT+CPBP="+331288575" <i>Note : Search entries corresponding to this phone number</i>	+CPBP : 15,"+331290101",145,"8045682344FFFF" (UCS2 format) OK <i>Note : Display the entry corresponding to the specified phone number</i>
AT+CPBP="0129" <i>Note : Search entries corresponding to this phone number</i>	+CME ERROR: 22 <i>Note : Entry not found</i>

8.5.3 Defined values

<PhoneNumber>

29th September 2004

coded according to GSM 07.07 or GSM 07.05.

8.6 Move action in phonebook +CPBN

8.6.1 Description

This specific command instructs the product to make a forward or backward move in the phonebook (in alphabetical order).

This command is not allowed for the "EN" phonebook which does not contain alphanumeric fields.

8.6.2 Syntax

Command syntax : AT+CPBN=<mode>

Command	Possible responses
AT+CPBN=? <i>Note : Test command</i>	+CPBN: (0-5) OK <i>Note : Possible modes</i>
AT+CPBN=0 <i>Note : Read the first location</i>	+CPBN: 15,"+331290101",145,"Eric" OK <i>Note : Display the first location</i>
AT+CPBN=2 <i>Note : Read the next location</i>	+CPBN: 5,"+33147658987",145,"Frank" OK <i>Note : Display the second location</i>
AT+CPBN=2 <i>Note : Read the next location</i>	+CPBN: 6,"+331290302",145,"Marc" OK <i>Note : Display the third location</i>
AT+CPBN=3 <i>Note : Read the previous location</i>	+CPBN: 5,"+33147658987",145,"Frank" OK <i>Note : Display the second location</i>
AT+CPBN=1 <i>Note : Read the last location</i>	+CPBN: 6,"+331290302",145,"Marc" OK <i>Note : Display the last location</i>
AT+CPBN=2 <i>Note : Read the next location</i>	+CPBN: 15,"+331290101",145,"Eric" OK <i>Note : Display the first location</i>

29th September 2004

Using mode 4 and 5 with +CPBF command and CPBW :

Command	Possible responses
AT+CPBF="Er" <i>Note : Find "Er" in phonebook</i>	+CPBF: 15,"+331290101",145,"Eric" OK <i>Note : Display the location</i>
AT+CPBN=2 <i>Note : Read the next location</i>	+CPBN: 5,"+33147658987",145,"Frank" OK <i>Note : Display the following location</i>
AT+CPBF="Er" <i>Note : Find "Er" in phonebook</i>	+CPBF: 15,"+331290101",145,"Eric" OK <i>Note : Display the location</i>
AT+CPBN=4 <i>Note : Get the last location read</i>	+CPBN: 15,"+331290101",145,"Eric" OK <i>Note : Display the last location read</i>
AT+CPBW="0146290800",129,"WM" <i>Note : Write an item at the first location available</i>	OK <i>Note : No information about this location</i>
AT+CPBN=4 <i>Note : Get the last location read</i>	+CPBN: 15,"+331290101",145,"Eric" OK <i>Note : Display the last location read</i>
AT+CPBN=5 <i>Note : Display the last item written with its location</i>	+CPBN: 38,"0146290800,129,"WM" OK <i>Note : Display the last item written with its location</i>
AT+CPBN=4 <i>Note : Get the last item read</i>	+CPBN: 38,"0146290800,129,"WM" OK <i>Note : Now the last item read is the last written item too</i>
AT+CPBF="800041FFFF" <i>Note : Find "800041" in phonebook</i>	+CPBF: 15,"+3312345",145,"8000414339FFFF" OK <i>Note : Display this location</i>
AT+CPBN=4 <i>Note : Get the last location read</i>	+CPBN: 15,"+3312345",145,"8000414339FFFF" OK <i>Note : Display the last location read</i>

29th September 2004

Please note that the AT+CPBN=5 command is useful after an AT+CPBW command used without a location.

8.6.3 Defined values

<mode>

- 0: First item
- 1: Last item
- 2: Next valid item in alphabetical order
- 3: Previous valid item in alphabetical order
- 4: Last item read (usable only if a read operation has been performed on the current phonebook since the end of initialization (+WIND: 4))
- 5: Last item written (usable only if a write operation has been performed on the current phonebook since the end of initialization (+WIND: 4))

8.7 Subscriber number +CNUM

8.7.1 Description

This command returns the subscriber MSISDN(s).

If the subscriber has different MSISDNs for different services, each MSISDN is returned in a separate line.

8.7.2 Syntax

Command syntax: AT+CNUM

Response syntax: +CNUM : <alpha1>, <number1>, <type1>

<CR><LF> +CNUM : <alpha2>, <number2>, <type2>

Command	Possible responses
AT+CNUM <i>Note : Get MSISDN(s)</i>	+CNUM:"Phone", "0612345678",129 +CNUM:"Fax", "0687654321",129 +CNUM: "80001002FFFF", "+0183773", 145 (UCS2 format) OK <i>Note : MSISDNs</i>
AT+CNUM=?	OK

29th September 2004

8.7.3 Defined values

- <alphax>** optional alphanumeric string associated with <numberx>
- <numberx>** string type phone number with format as specified by <typex>
- <typex>** type of address byte in integer format

8.8 Avoid phonebook init +WAIP

8.8.1 Description

This specific command allows the initialization of all phonebooks to be inhibited during subsequent boots.

8.8.2 Syntax

Command syntax : AT+WAIP=<mode>

Command	Possible responses
AT+WAIP? <i>Note : Current values ?</i>	+WAIP :0 OK <i>Note : Default value (init phonebooks)</i>
AT+WAIP=? <i>Note : Possible values ?</i>	+WAIP : (0,1) OK <i>Note : Disable / enable</i>
AT+WAIP =1 <i>Note : Inhibit initialization of phonebooks (next boot)</i>	OK <i>Note : no answer</i>
AT&W <i>Note : Save modifications in EEPROM</i>	

Caution:

the given value should be stored in EEPROM. Therefore, the AT&W command must be used to save the new <mode> value.

Note:

No phonebook commands are allowed if +WAIP=1 (after boot).

If a phonebook command is entered, a "+CME ERROR: 3" is returned.

8.8.3 Defined values

<mode>

0: Normal initialization (with phonebooks)

1: No phonebook initialization

8.9 Delete Calls Phonebook +WDCP

8.9.1 Description

This specific command allows to delete the calls listed in some phonebooks.

8.9.2 Syntax

Command syntax : AT+WDCP=<calls phonebook>

Command	Possible responses
AT+WDCP?	OK
AT+WDCP=? <i>Note : Possible values ?</i>	+WDCP : ("LD","MC","RC") OK <i>Note : Identifiers of the phonebooks supporting a list of calls</i>
AT+WDCP="LD" <i>Note : Delete all the content of Last Dialing phonebook.</i>	OK <i>Note : Last Dialing phonebook is now empty.</i>

8.9.3 Defined values

<calls phonebook>

- "LD": SIM (ME extended) Last dialing phonebook
- "MC": ME missed calls list phonebook
- "RC": ME received calls list phonebook

29th September 2004

8.10 Set Voice Mail Number +CSVM

8.10.1 Description

This commands allows to set/get and enable/disable the voice mail number in memory.

8.10.2 Syntax

Command syntax : AT+CSVM=<mode>[,<number>[,<type>]]

Command	Possible responses
AT+CSVM? <i>Note : Get mail number</i>	+CSVM: 1,"660",129 OK <i>Note : Voice mail number "660" is activated</i>
AT+CSVM=? <i>Note : Possible values ?</i>	+CSVM: (0-1),(129,145) OK <i>Note : activation/deactivation and format 129 & 145 are supported</i>
AT+CSVM=0,"888",129 <i>Note : Disable Voice Mail number and change value to "888".</i>	OK

8.10.3 Defined values

<mode>

- 0: Disable the voice mail number
- 1: Enable the voice mail number

<number>

Phone number in ASCII format.

<type>

TON/NPI (Type of address byte in integer format).

Note: Value is 145 if the dialing string (<number> response value) includes the international access code character '+', else. value is 129 (ex : a <type> value of 17 will be written as 145).

9 Short Messages commands

9.1 Parameters definition

- <da>** Destination Address, coded like GSM 03.40 TP-DA
- <dcS>** Data Coding Scheme, coded like in document [5].
- <dt>** Discharge Time in string format :
"yy/MM/dd, hh :mm :ss±zz"(Year [00-99], Month [01-12],
Day [01-31], Hour, Minute, Second and Time Zone [quarters of an
hour])
- <fo>** First Byte, coded like SMS-SUBMIT first byte in document [4],
default value is 17 for SMS-SUBMIT
- <index>** Place of storage in memory.
- <length>** Text mode (+CMGF=1): number of characters
PDU mode (+CMGF=0): length of the TP data unit in bytes
- <mem1>** Memory used to list, read and delete messages (+CMGL, +CMGR
and +CMGD).
- <mem2>** Memory used to write and send messages (+CMGW, +CMSS).
- <mid>** CBM Message Identifier.
- <mr>** Message Reference.
- <oa>** Originator Address.
- <pid>** Protocol Identifier.
- <pdu>** For **SMS** : GSM 04.11 SC address followed by GSM 03.40 TPDU in
hexadecimal format, coded as specified in doc [4] For **CBS** : GSM
03.41 TPDU in hexadecimal format
- <ra>** Recipient Address.
- <sca>** Service Center Address
- <scts>** Service Center Time Stamp in string format :
"yy/MM/dd, hh :mm :ss±zz"
(Year/Month/Day, Hour:Min:Seconds±TimeZone)
- <sn>** CBM Serial Number
- <st>** Status of a SMS-STATUS-REPORT
- <stat>** Status of message in memory.
- <toa>** Type-of-Address of <oa>.
- <tora>** Type-of-Address of <ra>.
- <tosca>** Type-of-Address of <sca>.

29th September 2004

- <total1> Number of message locations in <mem1>.
- <total2> Number of messages locations in <mem2>.
- <used1> Total number of messages locations in <mem1>.
- <used2> Total number of messages locations in <mem2>.
- <vp> Validity Period of the short message, default value is 167

9.2 Select message service +CSMS

9.2.1 Description

The supported services are originated (SMS-MO) and terminated short message (SMS-MT) + Cell Broadcast Message (SMS-CB) services.

9.2.2 Syntax

Command syntax : AT+CSMS=<service>

Command	Possible responses
AT+CSMS=0 <i>Note : SMS AT command Phase 2 version 4.7.0</i>	+CSMS: 1,1,1 OK <i>Note : SMS-MO, SMS-MT and SMS-CB supported</i>
AT+CSMS=1 <i>Note : SMS AT command Phase 2 +</i>	+CSMS: 1,1,1 <i>Note : SMS-MO, SMS-MT and SMS-CB supported</i>
AT+CSMS? <i>Note : Current values ?</i>	+CSMS: 0,1,1,1 OK <i>Note : GSM 03.40 and 03.41 (SMS AT command Phase 2 version 4.7.0)</i>
AT+CSMS=? <i>Note : Possible services</i>	+CSMS: (0,1) OK

9.2.3 Defined values

<service>

0: SMS AT commands are compatible with GSM 07.05 Phase 2 version 4.7.0.

1: SMS AT commands are compatible with GSM 07.05 Phase 2 + version .

9.3 New Message Acknowledgement +CNMA

9.3.1 Description

This command allows reception of a new message routed directly to the TE to be acknowledged.

In TEXT mode, only positive acknowledgement to the network (RP-ACK) is possible.

In PDU mode, either positive (RP-ACK) or negative (RP-ERROR) acknowledgement to the network is possible.

Acknowledge with +CNMA is possible only if the +CSMS parameter is set to 1 (+CSMS=1) when a +CMT or +CDS indication is shown (see +CNMI command).

If no acknowledgement is given within the network timeout, an RP-ERROR is sent to the network, the <mt> and <ds> parameters of the +CNMI command are then reset to zero (do not show new message indication).

9.3.2 Syntax

Command syntax in text mode :

AT+CNMA

Command syntax in PDU mode :

AT+CNMA [= <n> [, <length> [<CR>

PDU is entered <ctrl-Z / ESC>]]]

Note:

PDU is entered using <ackpdu> format instead of <pdu> format (e.g.. SMSC address field is not present).

29th September 2004

Example of acknowledgement of a new message in TEXT mode

Command	Possible responses
AT+CSMS=1 <i>Note: SMS AT commands compatible with GSM 07.05 Phase 2 + version</i>	OK
AT+CMGF=1 <i>Note : Set TEXT mode</i>	OK <i>Note : TEXT mode valid</i>
AT+CNMI=2,2,0,0,0 <i>Note : <mt>=2</i>	OK
	+CMT : "123456","98/10/01,12 :30 00+00",129,4 ,32,240, "15379",129,5<CR><LF> Received message <i>Note : message received</i>
AT+CNMA <i>Note : acknowledge the message received</i>	OK <i>Note : send positive acknowledgement to the network</i>
AT+CNMA <i>Note : try to acknowledge again</i>	+CMS ERROR : 340 <i>Note : no +CNMA acknowledgment expected</i>

29th September 2004

Example of acknowledgement of a new message in PDU mode:

Command	Possible responses
AT+CSMS=1 <i>Note: SMS AT commands compatible with GSM 07.05 Phase 2 + version</i>	OK
AT+CMGF=0 <i>Note : Set PDU mode</i>	OK <i>Note : PDU mode valid</i>
AT+CNMI=2,2,0,0,0 <i>Note : <mt>=2</i>	OK
	+CMT: ,29 07913366003000F1240B913366920547 F30000003003419404800B506215D42E CFE7E17319 <i>Note : message received</i>
AT+CNMA=2,2<CR> >00D3 <Ctrl-Z> <i>Note: Negative ACK to the SMS. Reason is: memory capacity exceeded</i>	OK
AT+CNMA=2,2<CR> >00D0 <Ctrl-Z> <i>Note: Negative ACK to the SMS. Reason is: SIM memory storage is full</i>	OK
AT+CNMA=2,2<CR> >00D2 <Ctrl-Z> <i>Note: Negative ACK to the SMS. Reason is: Error in MS</i>	OK
AT+CNMA=2,2<CR> >00FF <Ctrl-Z> <i>Note: Negative ACK to the SMS. Unspecified error</i>	OK

9.3.3 Defined values

<n> : Type of acknowledgement in PDU mode

0: send RP-ACK without PDU (same as TEXT mode)

1: send RP-ACK with optional PDU message

2: send RP-ERROR with optional PDU message

<length>: Length of the PDU message

29th September 2004

Please refer to GSM 03.40 Recommendation for other PDU negative acknowledgement codes.

9.4 Preferred Message Storage +CPMS

9.4.1 Description

This command allows the message storage area to be selected (for reading, writing, etc).

9.4.2 Syntax

Command syntax : AT+CPMS=<mem1>,[<mem2>]

Command	Possible responses
AT+CPMS=? <i>Note : Possible message storages</i>	+CPMS: (("SM","BM","SR"),("SM")) OK <i>Note :</i> <i>Read, list, delete: SMS, CBM or SMS Status Report</i> <i>Write, send: SMS</i>
AT+CPMS? <i>Note : Read</i>	+CPMS: "SM",3,10,"SM",3,10 OK <i>Note : Read, write...SMS from/to SIM</i> <i>3 SMS are stored in SIM. 10 is the total memory available in SIM</i>
AT+CPMS="AM" <i>Note : Select false message storage</i>	+CMS ERROR: 302
AT+CPMS="BM" <i>Note : Select CBM message storage</i>	+CPMS: 2,20,3,10 OK <i>Note : Read, list, delete CBM from RAM</i> <i>2 CBM are stored in RAM</i>
AT+CPMS? <i>Note : Read</i>	+CPMS: "BM",2,20,"SM",3,10 OK <i>Note :</i> <i>Read list, delete CBM from RAM</i> <i>Write SMS to SIM</i>

29th September 2004

9.4.3 Defined values

<mem1>: Memory used to list, read and delete messages. It can be:

- "SM": SMS message storage in SIM (default)

- "BM": CBM message storage (in volatile memory).

- "SR" : Status Report message storage (in SIM if the EF-SMR file exists, otherwise in the ME non volatile memory)

Note :

"SR" ME non volatile memory is cleared when another SIM card is inserted. It is kept, even after a reset, while the same SIM card is used.

<mem2>: Memory used to write and send messages

- "SM" : SMS message storage in SIM (default).

If the command is correct, the following message indication is sent:

+CPMS: <used1>,<total1>,<used2>,<total2>

When <mem1> is selected, all following +CMGL, +CMGR and +CMGD commands are related to the type of SMS stored in this memory.

9.5 Preferred Message Format +CMGF

9.5.1 Description

The message formats supported are *text mode* and *PDU mode*.

In PDU mode, a complete SMS Message including all header information is given as a binary string (in hexadecimal format). Therefore, only the following set of characters is allowed: {'0','1','2','3','4','5','6','7','8','9', 'A', 'B','C','D','E','F'}. Each pair or character is converted to a byte (e.g.: '41' is converted to the ASCII character 'A', whose ASCII code is 0x41 or 65).

In Text mode, all commands and responses are in ASCII characters.

The selected format is stored in EEPROM by the +CSAS command.

29th September 2004

9.5.2 Syntax

Command syntax : AT+CMGF=<mode>

Command	Possible responses
AT+CMGF? <i>Note : Current message format</i>	+CMGF:1 OK <i>Note : Text mode</i>
AT+CMGF=? <i>Note : Possible message format</i>	+CMGF: (0,1) OK <i>Note : Text or PDU modes are available</i>

Example, sending an SMS Message in PDU mode

Command	Possible responses
AT+CMGF=0 <i>Note : Set PDU mode</i>	OK <i>Note : PDU mode valid</i>
AT+CMGS=14<CR> 0001030691214365000004C9E9340B <i>Note : Send complete MSG in PDU mode, no SC address</i>	+CMGS: 4 OK <i>Note : MSG correctly sent, <mr> is returned</i>

9.5.3 Defined values

<mode> PDU or text mode

0	PDU mode
1	Text mode

The <pdu> message is composed of the SC address (00 means no SC address given, use default SC address read with +CSCA command) and the TPDU message.

In this example, the length in **bytes** of the TPDU buffer is 14, coded as GSM 03.40

In this case the TPDU is : 0x01 0x03 0x06 0x91 0x21 0x43 0x65 0x00 0x00 0x04 0xC9 0xE9 0x34 0x0B, which means regarding GSM 03.40 :

29th September 2004

<fo>	0x01 (SMS-SUBMIT, no validity period)
<mr> (TP-MR)	0x03 (Message Reference)
<da> (TP-DA)	0x06 0x91 0x21 0x43 0x65 (destination address +123456)
<pid> (TP-PID)	0x00 (Protocol Identifier)
<dc> (TP-DCS)	0x00 (Data Coding Scheme : 7 bits alphabet)
<length> (TP-UDL)	0x04 (User Data Length, 4 characters of text)
TP-UD	0xC9 0xE9 0x34 0x0B (User Data : ISSY)

TPDU in hexadecimal format must be converted into two ASCII characters. For example, the byte 0x2A is presented to the ME as two characters '2' (ASCII 50) and 'A' (ASCII 65).

9.6 Save Settings +CSAS

9.6.1 Description

All settings specified by the +CSCA and +CSMP commands are stored in EEPROM if the SIM card is a Phase 1 card or in the SIM card if it is a Phase 2 SIM card.

9.6.2 Syntax

Command syntax : AT+CSAS

Command	Possible responses
AT+CSAS <i>Note : Store +CSCA and +CSMP parameters</i>	OK <i>Note : Parameters saved</i>

9.6.3 Defined values

No parameter

9.7 Restore settings +CRES

9.7.1 Description

All settings specified in the +CSCA and +CSMP commands are restored from EEPROM if the SIM card is Phase 1 or from the SIM card if it is a Phase 2 one.

9.7.2 Syntax

Command syntax : AT+CRES

Command	Possible responses
AT+CRES <i>Note : Restore +CSCA and +CSMP parameters</i>	OK <i>Note : Parameters restored</i>

9.7.3 Defined values

No parameter

9.8 Show text mode parameters +CSDH

9.8.1 Description

This command gives additional information on text mode result codes. These informations can be found in description of the +CMT, +CMGR, +CMGL commands and responses.

9.8.2 Syntax

Command syntax : AT+CSDH=<n>

Command	Possible responses
AT+CSDH=0 <i>Note: Set value to "do not show"</i>	OK
AT+CSDH? <i>Note : Current value</i>	+CSDH: 0 OK <i>Note : Do not show header values</i>

9.8.3 Defined values:

<n>: show indicator

- 0: do not show header values
- 1: show the values in result codes

9.9 New message indication +CNMI

9.9.1 Description

This command selects the procedure for message reception from the network.

9.9.2 Syntax :

Command syntax : AT+CNMI=<mode>,<mt>,<bm>,<ds>,<bfr>

Command	Possible responses
AT+CNMI=2,1,0,0,0 <i>Note : <mt>=1</i>	OK
	AT+CMTI : "SM",1 <i>Note : message received</i>
AT+CNMI=2,2,0,0,0 <i>Note : <mt>=2</i>	OK
	+CMT : "123456","98/10/01,12 :30 00+00",129,4 ,32,240, "15379",129,5<CR><LF> <i>Note : message received</i>
AT+CNMI=2,0,0,1,0 <i>Note : <ds>=1</i>	OK
AT+CMGS="+33146290800"<CR> Happy Birthday !<ctrl-Z> <i>Note : Send a message in text mode</i>	+CMGS : 7 OK <i>Note : Successful transmission</i>
	+CDS : 2, 116, "+33146290800", 145, "98/10/01,12 :30 :07+04", "98/10/01 12 :30 :08+04", 0 <i>Note : message was correctly delivered</i>

9.9.3 Defined values

<mode> : controls the processing of unsolicited result codes

0: Buffer unsolicited result codes in the TA. If TA result code buffer is full, indications can be buffered in some other place or the oldest indications may be discarded and replaced with the new received indications

29th September 2004

- 1: Discard indication and reject new received message unsolicited result codes when TA-TE link is reserved. Otherwise forward them directly to the TE
- 2: Buffer unsolicited result codes in the TA when TA-TE link is reserved and flush them to the TE after reservation. Otherwise forward them directly to the TE
- 3: Forward unsolicited result codes directly to the TE. TA-TE link specific inband used to embed result codes and data when TA is in on-line data mode

Important note : only <mode>=2 is supported.

Any other value for <mode> (0,1 or 3) is accepted (return code will be *OK*), but the processing of unsolicited result codes will be the same as with <mode>=2.

29th September 2004

<mt> : sets the result code indication routing for SMS-DELIVER indications. Default is 1.

0: No SMS-DELIVER indications are routed.

1: SMS-DELIVERs are routed using unsolicited code : +CMTI: "SM", <index>

2: SMS-DELIVERs (except class 2 messages) are routed using unsolicited code :

if PDU mode :

+CMT : [<alpha>], <length> <CR> <LF> <pdu>

if text mode :

+CMT : <oa>,<alpha>, <scts> [,<tooa>, <fo>, <pid>, <dcsc>, <sca>, <tosca>, <length>] <CR><LF><data>

3: Class 3 SMS-DELIVERs are routed directly using code in <mt>=2 ; Other classes messages result in indication <mt>=1

<bm> : defines the rules for storing the received CBMs (Cell Broadcast Message) types. They depend also on the coding scheme (text or PDU) and the setting of Select CBM Types (see +CSCB command). Default is 0.

0: No CBM indications are routed to the TE. The CBMs are stored.

1: The CBM is stored and an indication of the memory location is routed to the customer application using unsolicited result code: +CBMI: "BM", <index>

2: New CBMs are routed directly to the TE using unsolicited result code.

If PDU mode :

+CBM : <length><CR><LF><pdu> or

If text mode :

+CBM :<sn>,<mid>,<dcsc>,<page>,<pages> <CR><LF> <data>

3: Class 3 CBMs : as <bm>=2.

Other classes CBMs : as <bm>=1.

<ds> for SMS-STATUS-REPORTs. Default is 0.

0: No SMS-STATUS-REPORTs are routed.

1: SMS-STATUS-REPORTs are routed using unsolicited code :

If PDU mode :

+CDS : <length> <CR> <LF> <pdu> (PDU mode) or

If text mode :

+CDS : <fo>,<mr>, [<ra>] , [<tora>], <scts>,<dt>,<st> (Text mode)

2: SMS-STATUS-REPORTs are stored and routed using the unsolicited result code : +CDSI: "SR",<index>

<bfr> Default is 0.

29th September 2004

0: TA buffer of unsolicited result codes defined within this command is flushed to the TE when <mode> = 1 to 3 is entered (OK response shall be given before flushing the codes)

1: TA buffer of unsolicited result codes defined within this command is cleared when <mode> 1...3 is entered.

9.10 Read message +CMGR

9.10.1 Description

This command allows the application to read stored messages. The messages are read from the memory selected by +CPMS command.

9.10.2 Syntax

Command syntax : AT+CMGR=<index>

Response syntax for text mode:

+CMGR :<stat>,<oa>,[<alpha>] <scts> [,<tooa>,<fo>,

<pid>,<dcs>,<sca>,<tosca>,<length>] <CR><LF> <data> (for **SMS-DELIVER** only)

+CMGR : <stat>,<da>,[<alpha>] [,<toda>,<fo>,<pid>,<dcs>] [,<vp>], <sca>,<tosca>,<length>]<CR><LF> <data> (for **SMS-SUBMIT** only)

+CMGR : <stat>,<fo>,<mr>,[<ra>],[<tora>],<scts>,<dt>,<st> (for **SMS-STATUS-REPORT** only)

Response syntax for PDU mode :

+CMGR: <stat> , [<alpha>] ,<length> <CR><LF> <pdu>

A message read with status "REC UNREAD" will be updated in memory with the status "REC READ".

Note :

the <stat> parameter for SMS Status Reports is always "READ".

29th September 2004

Example :

Command	Possible responses
	+CMTI: "SM",1 <i>Note : New message received</i>
AT+CMGR=1 <i>Note : Read the message</i>	+CMGR: "REC UNREAD","0146290800", "98/10/01,18 :22 :11+00",<CR><LF> ABCdefGHI OK
AT+CMGR=1 <i>Note : Read the message again</i>	+CMGR: "REC READ","0146290800", "98/10/01,18 :22 :11+00",<CR><LF> ABCdefGHI OK <i>Note : Message is read now</i>
AT+CMGR=2 <i>Note : Read at a wrong index</i>	+CMS ERROR: 321 <i>Note : Error : invalid index</i>
AT+CMGF=0 ;+CMGR=1 <i>Note : In PDU mode</i>	+CMGR: 2,,<length> <CR><LF><pdu> OK <i>Note : Message is stored but unsent, no <alpha>field</i>
AT+CMGF=1;+CPMS="SR";+CNMI=,,,2 <i>Reset to text mode, set read memory to "SR", and allow storage of further SMS Status Report into "SR" memory</i>	OK
AT+CMSS=3 <i>Send an SMS previously stored</i>	+CMSS: 160 OK
	+CDSI: "SR",1 <i>New SMS Status Report stored in "SR" memory at index 1</i>
AT+CMGR=1 <i>Read the SMS Status Report</i>	+CMGR: "REC UNREAD",6,160, "+33612345678",129,"01/05/31,15:15:0 9+00", "01/05/31,15:15:09+00",0 OK

9.10.3 Defined values

See paragraph 9.1.

9.11 List message +CMGL

9.11.1 Description

This command allows the application to read stored messages, by indicating the type of the message to read. The messages are read from the memory selected by the +CPMS command.

9.11.2 Syntax

Command syntax : AT+CMGL=<stat>

Response syntax for text mode:

+CMGL : <index>,<stat>,<da/oa>,[<alpha>], [<scts>, <tooa/toda>, <length>]
<CR><LF><data> (for **SMS-DELIVER** and **SMS-SUBMIT**, may be followed by other <CR><LF>+CMGL:<index>...)

+CMGL : <index>,<stat>,<fo>,<mr>,[<ra>],[<tora>],<scts>,<dt>,<st> (for **SMS-STATUS-REPORT** only, may be followed by other <CR><LF>+CMGL:<index> ...)

Response syntax for PDU mode :

+CMGL : <index>,<stat>, [<alpha>], <length> <CR><LF> <pdu> (for **SMS-DELIVER**, **SMS-SUBMIT** and **SMS-STATUS-REPORT**, may be followed by other <CR><LF>+CMGL:<index>...)

29th September 2004

Command	Possible responses
AT+CMGL="REC UNREAD" <i>Note : List unread messages in text mode</i>	+CMGL: 1,"REC UNREAD","0146290800",, <CR><LF> I will be late +CMGL: 3,"REC UNREAD", "46290800", <CR><LF>See you tonight ! OK <i>Note : 2 messages are unread, these messages will then have their status changed to "REC READ"</i>
AT+CMGL="REC READ" <i>Note : List read messages in text mode</i>	+CMGL: 2,"REC READ","0146290800",, <CR><LF> Keep cool OK
AT+CMGL="STO SENT" <i>Note : List stored and sent messages in text mode</i>	OK <i>Note : No message found</i>
AT+CMGL=1 <i>Note : List read messages in PDU mode</i>	+CMGL: 1,1,,26 <CR><LF> 07913366003000F3040B913366920547 F40013001190412530400741AA8E5A9C 5201 OK

9.11.3 Defined values

<stat> possible values (status of messages in memory) :

Text mode possible values	PDU mode possible values	Status of messages in memory
"REC UNREAD"	0	received unread messages
"REC READ"	1	received read messages
"STO UNSENT"	2	stored unsent messages
"STO SENT"	3	stored sent messages
"ALL"	4	all messages

Note :

For SMS Status Reports, only "ALL" / 4 and "READ" / 1 values of the <stat> parameter will list messages ; other values will only return OK.

29th September 2004

9.12 Send message +CMGS

9.12.1 Description

The <address> field is the address of the terminal to which the message is sent. To send the message, simply type, <ctrl-Z> character (ASCII 26). The text can contain all existing characters except <ctrl-Z> and <ESC> (ASCII 27).

This command can be aborted using the <ESC> character when entering text.

In PDU mode, only hexadecimal characters are used ('0'...'9','A'...'F').

9.12.2 Syntax

Command syntax in text mode :

AT+CMGS= <da> [,<tda>] <CR>

text is entered <ctrl-Z / ESC >

Command syntax in PDU mode :

AT+CMGS= <length> <CR>

PDU is entered <ctrl-Z / ESC >

Command	Possible responses
AT+CMGS="+33146290800"<CR>	>
----- Please call me soon, Fred. <ctrl-Z> <i>Note : Send a message in text mode</i>	
-----	+CMGS: <mr> OK <i>Note : Successful transmission</i>
AT+CMGS=<length><CR> <i>Note : Send a message in PDU mode (1/3)</i>	>
----- <pdu> <i>Note : Enter message in PDU mode (2/3)</i>	
----- <ctrl-Z> <i>Note : End the message (3/3)</i>	+CMGS: <mr> OK <i>Note : Successful transmission</i>

The message reference, <mr>, which is returned to the application is allocated by the product. This number begins with 0 and is incremented by one for each

29th September 2004

outgoing message (successful and failure cases); it is cyclic on one byte (0 follows 255).

Note: this number is not a storage number – outgoing messages are not stored.

9.12.3 Defined values

See paragraph 9.1.

9.13 Write Message to Memory +CMGW

9.13.1 Description

This command stores a message in memory (either SMS-SUBMIT or SMS-DELIVERS). The memory location <index> is returned (no choice possible as with phonebooks +CPBW).

Text or PDU is entered as described for the Send Message +CMGS command.

9.13.2 Syntax

Command syntax in text mode : (<index> is returned in both cases)

AT+CMGW= <oa/da> [,<tooa/toda> [,<stat>]] <CR>

enter text <ctrl-Z / ESC>

Command syntax in PDU mode :

AT+CMGW= <length> [,<stat>] <CR>

give PDU <ctrl-Z / ESC>

Response syntax:

+CMGW: <index> or +CMS ERROR: <err> if writing fails

Command	Possible responses
AT+CMGW=" +33146290800" <CR>	>
Hello how are you ?<ctrl-Z> <i>Note : Write a message in text mode</i>	
	+CMGW: 4 OK <i>Note : Message stored in index 4</i>
AT+ CMGW = <length> <CR>	>
<i>Note : Write a message in PDU mode (1/3)</i>	
<pdu>	
<i>Note : Enter message in PDU mode (2/3)</i>	
<ctrl-Z>	+CMGW: <index>
<i>Note : End the message (3/3)</i>	OK <i>Note : Message stored in <index></i>

29th September 2004

9.13.3 Defined values

- <oa/da>** Originating or Destination Address Value in string format.
- <tooa/toda>** Type of Originating / Destination Address.
- <stat>** Integer type in PDU mode (*default 2 for +CMGW*), or string type in text mode (*default "STO UNSENT" for +CMGW*). Indicates the status of message in memory. If <stat> is omitted, the stored message is considered as a message to send.
- 0 "REC UNREAD"
 - 1 "REC READ"
 - 2 "STO UNSENT"
 - 3 "STO SENT"
- <length>** Length of the actual data unit in bytes

9.14 Send Message From Storage +CMSS

9.14.1 Description

This command sends a message stored at location value <index>.

9.14.2 Syntax

Command syntax: AT+CMSS=<index>[,<da> [,<toda>]]

Response syntax:

+CMSS : <mr> or +CMS ERROR: <err> if sending fails

If a new recipient address <da> is given, it will be used instead of the one stored with the message

Command	Possible responses
AT+CMGW=0660123456<CR> Today is my birthday <i>Note :</i>	+CMGW : 5 OK <i>Note :Message stored with index 5</i>
AT+CMSS=5, 0680654321 <i>Note : Send the message 5 to a different destination number</i>	+CMSS :<mr> OK <i>Note : Successful transmission</i>

29th September 2004

9.14.3 Defined values

<index>

<da>

<toda>

<mr>

See above descriptions.

29th September 2004

9.15 Set Text Mode Parameters +CSMP

9.15.1 Description

This command is used to select a value for <vp>, <pid>, and <dc>.

9.15.2 Syntax ;

Command syntax : AT+CSMP=<fo>, <vp>, <pid>,<dc>

Command	Possible responses
AT+CSMP? <i>Note : current values</i>	+CSMP: 0,0,0,0 OK <i>Note : No validity period</i> <dc>= PCCP437 alphabet (8 bits → 7 bits)
AT+CSMP=17,23,64,244 <i>Note :<vp> = 23 (2 hours, relative format)</i> <dc> = GSM 8 bits alphabet Remind to enter <fo> value in decimal notation.	OK <i>Note : Command correct</i>

9.15.3 Defined values

The <fo> byte comprises 6 different fields :

b7	b6	B5	b4	b3	b2	b1	b0
RP	UDH /	SRR	VPF		RD	MTI	

Note: <fo> must be entered in DECIMAL format. Hexadecimal format would lead to unrelevant result.

RP : Reply Path, not used in text mode.

UDHI : User Data Header Information, b6=1 if the beginning of the User Data field contains a Header in addition to the short message. This option is not supported in +CSMP command, but can be used in PDU mode (+CMGS).

SRR : Status Report Request, b5=1 if a status report is requested. This mode is supported.

29th September 2004

VPF : Validity Period Format

b4=0 & b3=0 -> <vp> field is not present

b4=1 & b3=0 -> <vp> field is present in relative format

Others formats (absolute & enhanced) are not supported.

RD : Reject Duplicates, b2=1 to instruct the SC to reject an SMS-SUBMIT for an SM still held in the SC which has the same <mr> and the same <da> as the previously submitted SM from the same <oa>.

MTI : Message Type Indicator

b1=0 & b0=0 -> SMS-DELIVER (in the direction SC to MS)

b1=0 & b0=1 -> SMS-SUBMIT (in the direction MS to SC)

In text mode <vp> is only coded in "relative" format. The default value is 167 (24 hours). This means that one byte can describe different values :

VP value	Validity period value
0 to 143	(VP + 1) x 5 minutes (up to 12 hours)
144 to 167	12 hours + (VP - 143) x 30 minutes)
168 to 196	(VP - 166) x 1 day
197 to 255	(VP - 192) x 1 week

<pid> is used to indicate the higher layer protocol being used or indicates interworking with a certain type of telematic device. For example, 0x22 is for group 3 telefax, 0x24 is for voice telephone, 0x25 is for ERMES (European Radio Messaging System).

<dcs> is used to determine the way the information is encoded. Compressed text is not supported. Only GSM default alphabet, 8 bit data and UCS2 alphabet are supported.

9.16 Delete message +CMGD

9.16.1 Description

This command is used to delete one or several messages from preferred message storage ("BM" SMS-CB 'RAM storage', "SM" SMSPP storage 'SIM storage' or "SR" SMS Status-Report storage).

Refer also to Preferred Message Storage +CPMS command.

9.16.2 Syntax

Command syntax : AT+CMGD=<Index> [,<DelFalg>]

Command	Possible responses
	+CMTI:"SM",3 <i>Note : New message received</i>
AT+CMGR=3 <i>Note : Read it</i>	+CMGR: "REC UNREAD","0146290800", "98/10/01,18 :19 :20+00" <CR><LF> Message received! <i>Note : Unread message received from 0146290800 on the 01/10/1998 at 18H19m 20s</i>
AT+CMGD=3 <i>Note : Delete it</i>	OK <i>Note : Message deleted</i>
AT+CMGD=1,0	OK <i>Note : The message from the preferred message storage at the location 1 is deleted</i>
AT+CMGD=1,1	OK <i>Note : All READ messages from the preferred message storage are deleted</i>
AT+CMGD=1,2	OK <i>Note : All READ messages and SENT mobile originated messages are deleted</i>
AT+CMGD=1,3	OK <i>Note : All READ, SENT and UNSENT messages are deleted</i>
AT+CMGD=1,4	OK <i>Note : All messages are deleted</i>

29th September 2004

9.16.3 Defined values**<index>** if DelFlag=0

- (1-20) if the preferred message storage is "BM"
- SIM dependant integer values (in the range of SIM location number) if the preferred message storage is "SM" or "SR".

If DelFlag is different from 0, **<index>** is ignored.

<DelFlag>

- 0 Delete message at location **<index>** (default value).
- 1 Delete All READ messages
- 2 Delete All READ and SENT messages
- 3 Delete All READ, SENT and UNSENT messages
- 4 Delete All messages.

If **<DelFlag>** is omitted, default value is used.

Note : when the preferred message storage is "SR", as SMS status reports are assumed to have a "READ" status, if **<DelFlag>** is greater than 0, all SMS status reports will be deleted.

9.17 Service center address +CSCA**9.17.1 Description**

This command is used to indicate to which service center the message must be sent.

The product has no default value for this address. If the application tries to send a message without having indicated the service center address, an error will be generated.

Therefore, the application must indicate the SC address when initialising the SMS. This address is then permanently valid. The application may change it if necessary.

9.17.2 Syntax

Command syntax : AT+CSCA=<sca>

Command	Possible responses
AT+CMGS= "+33146290800"<CR> Hello, how are you?<ctrl-Z> <i>Note : Send a message</i>	+CMS ERROR: 330 <i>Note : service center unknown</i>
AT+CSCA="0696741234" <i>Note : Service center initialization</i>	OK <i>Note :</i>
AT+CMGS="+33146290800"<CR> Happy Birthday ! <ctrl-Z> <i>Note :</i>	+CMGS: 1 OK <i>Note : Successful transmission</i>

9.17.3 Defined values

<sca>

See above descriptions

9.18 Select Cell Broadcast Message Types +CSCB

9.18.1 Description

This command selects which types of CBMs are to be received by the ME. It is allowed in both PDU and text modes.

9.18.2 Syntax :

Command syntax: AT+CSCB= <mode>, [<mids>, [<dcss>]]

Important note : Test read command (AT+CSCB ?) is not supported.

29th September 2004

Command	Possible responses
AT+CSCB=0,"15-17,50,86","" <i>Note : Accept SMS-CB types, 15,16,17,50 and 86 in any language</i>	OK <i>Note : CBMs can be received</i>
	+CBM : 10<CR><LF> 00112233445566778899 <i>Note : CBM length of a received Cell Broadcast message (SMS-CB), CBM bytes in PDU mode)</i>
AT+CSCB=1 <i>Note : Deactivate the reception of CBMs</i>	OK <i>Note : CBM reception is completely stopped</i>

9.18.3 Defined values

The <bm> parameter of +CNMI command controls the message indication.

The activation of CBM reception (<mode>=0) can select only specific Message Identifiers (list in <mids>) for specific Languages (list in <dcss>), but the deactivation stops any reception of CBMs (only AT+CSCB=1 is allowed)

Message Identifiers (<mids> parameter) indicates to which type of message identifiers the ME should listen.

<dcss> : Supported languages

- 0 German
- 1 English
- 2 Italian
- 3 French
- 4 Spanish
- 5 Dutch
- 6 Swedish
- 7 Danish
- 8 Portuguese
- 9 Finnish
- 10 Norwegian
- 11 Greek
- 12 Turkish
- 13 Hungarian
- 14 Polish
- 32 Czech.

9.19 Cell Broadcast Message Identifiers +WCBM

9.19.1 Description

This specific command is used to read the EF-CBMI SIM file.

Remark: The EF-CBMI file is not used with the +CSCB command.

The application should read this file (using AT+WCBM ?) and combine the Message Identifiers with those required by the application.

9.19.2 Syntax

Command syntax : AT+WCBM= <mids>

Command	Possible responses
AT+WCBM="10,100,1000,10000" <i>Note : Write 4 messages identifiers in EF-CBMI</i>	OK <i>Note : CBMIs are stored in EF-CBMI</i>
AT+WCBM? <i>Note : Read the CBMIs in EF-CBMI</i>	+WCBM="10,100,1000,10000" OK <i>Note : 4 CBMIs are stored in EF-CBMI</i>

9.19.3 Defined values

<mids>

See above descriptions

29th September 2004

9.20 Message status modification +WMSC

9.20.1 Description

This commands allow the manipulation of a message status. The accepted status changes are from READ to NOT READ and vice versa, and from SENT to NOT SENT and vice versa.

9.20.2 Syntax:

Command syntax : AT+WMSC= <loc>, <status>

Command	Possible responses
AT+CMGR=2	+CMGR: "REC READ","+336290918",,"99/05/01 14:19:44+04" <CR><LF> Hello All of you ! OK
AT+WMSC=2,"REC UNREAD"	
AT+CMGR=2	+CMGR: "REC UNREAD","+336290918",,"99/05/01 14:19:44+04" <CR><LF> Hello All of you ! OK

Possible responses:

OK if the location is valid
 +CMS ERROR: 321 if <loc> is invalid or free
 +CMS ERROR: 302 if the new <status> and the previous one are incompatible (1)

Note 1 :

If all the parameters are correct, the product overwrites the whole SMS in SIM. Only the first byte (Status byte) is changed.

9.20.3 Defined values

<loc> location number of the stored message (integer)
 <status> new status to be stored, as for +CMGL command :

29th September 2004

PDU Mode	Text Mode
0	"REC UNREAD"
1	"REC READ"
2	"STO UNSENT"
3	"STO SENT"

9.21 Message overwriting +WMGO

9.21.1 Description

The WMGO command is used to specify a location in the SIM, for the next SMS storing with +CMGW command. The defined location is used only once : +WMGO has to be used again to perform another overwrite.

Important notes :

- If the external application specifies a free location, and an incoming message is received before the AT+CMGW command occurs, the product may store the incoming message at the specified available location. If the user then issues an AT+CMGW command without changing the location with another AT+WMGO, the received message will be overwritten.
- The location number is not kept over a software reset.

9.21.2 Syntax

Command syntax: AT+WMGO= <loc>

Command	Possible responses
AT+CMGW="+33146290800"<CR> Hello how are you ?<ctrl-Z>	+CMGW: 4 OK
<i>Note : Write a message in text mode</i> AT+WMGO=4	<i>Note : Message stored in index 4</i>
AT+CMGW="+33146299704"<CR> You are overwritten<ctrl-Z>	+CMGW: 4 OK
	<i>Note : New Message stored in index 4</i>

29th September 2004

AT+WMGO?	+WMGO: 4 OK
AT+WMGO=999	+CMS ERROR: 321
AT+WMGO=?	+WMGO: [<range of location>] OK

9.21.3 Defined values

<loc> location number of the SIM record to write or overwrite. Number depending of the SIM capacity.

29th September 2004

9.22 Un-change SMS Status +WUSS

9.22.1 Description

The +WUSS command allows to keep the SMS Status to UNREAD after +CMGR or +CMGL.

9.22.2 Syntax

Command syntax : AT+WUSS = <mode>

Command	Possible responses
AT+WUSS=?	+WUSS(0,1) OK
AT+WUSS=1	OK
	+CMTI: "SM",10 <i>Note : SMS has been received in index 10</i>
AT+CMGR=10	+CMGR: "REC UNREAD", "+33660669023", "03/02/13,18:36:35+00" <CR>< LF> Do you want to change state ? OK
AT+CMGR=10	+CMGR: "REC UNREAD", "+33660669023", "03/02/13,18:36:35+00" <CR>< LF> Do you want to change state ? OK <i>Note : The state hasn't be updated</i>
AT+WUSS=0	OK
	+CMTI: "SM",11 <i>Note : SMS has been received in index 11</i>
AT+CMGR=10	+CMGR: "REC UNREAD", "+33660669023", "03/02/13,18:56:55+00" <CR>< LF> It is me again. OK

29th September 2004

AT+CMGR=10	+CMGR: READ", "+33660669023", "03/02/13,18:56:55+00" <CR><LF> It is me again. OK <i>Note : The state has been updated</i>	"REC
AT+WUSS?	+WUSS:0 OK	

9.22.3 Defined values

<mode>

<mode> : 1 The SMS Status will not change.

<mode> : 0 The SMS Status will change.

9.23 More Messages to Send +CMMS

9.23.1 Description

This short message service-oriented AT command allows to keep the link opened while sending several short messages within a short delay.

9.23.2 Syntax

Command syntax: AT+CMMS = <mode>

Command	Possible responses
AT+ CMMS=0 <i>Note : Disable feature</i>	OK <i>Note : feature is disabled</i>
AT+ CMMS=1 <i>Note : Enable feature 1 time</i>	OK <i>Note : feature is enabled, link is open</i>
AT+ CMMS=2 <i>Note : Enable feature</i>	OK <i>Note : feature is enabled, link is open</i>
AT+ CMMS?	+CMMS: 2 OK
AT+ CMMS=?	+CMMS: (0-2) OK

29th September 2004

9.23.3 Defined values

<mode>

- 0 Disable feature
- 1 Keep link opened while messages are sent. If the delay between two messages exceeds 5 seconds, the link is closed and the mode is reset to 0: the feature is disabled.
- 2 Keep link opened while messages are sent. If the delay between two messages exceeds 5 seconds, the link is closed but the mode remains set to 2: the feature is still enabled.

Notes:

- The delay of 5 seconds complies with Rec 3GPP 27.005 §3.5.6.
- Before sending the last SMS in the link, you must use AT+CMMS=0 command. This command will indicate that the **FOLLOWING** SMS will be the last one.

29th September 2004

- 2 No reply
- 3 Not reachable
- 4 All call forwarding
- 5 All conditional call forwarding

<mode>

- 0 Disable
- 1 Enable
- 2 Interrogate
- 3 Registration
- 4 Erasure

<type> : TON/NPI (Type of address byte in integer format) (default 145 when dialing string includes international access code character "+", otherwise 129)

<class>

- 1 Voice
- 2 Data
- 4 Fax
- 8 Short Messages
- 7 All classes

Note: The combination of different classes is not supported, it will only result in the activation / deactivation / status request of all classes (7).

If the FDN phonebook is activated, the registration is restricted to the phone numbers written in it.

if <Class> parameter is not given in the command, 7 is used as default value.

<subaddr> not managed

<satype> not managed

<time> For <reason> = 2 (No reply), 4 (all calls forwarding) and 5 (all conditional call forwarding), time to wait (1 to 30) in seconds before call is forwarded. Default value is 20.

< status >

- 0 : not active
- 1 : active

29th September 2004

10.2 Call barring +CLCK

10.2.1 Description

This command allows control of the call barring supplementary service.

Locking, unlocking or querying the status of call barring is possible for all classes or for a specific class, but not a combination of some.

10.2.2 Syntax

Command Syntax : AT+CLCK= <fac>, <mode> [, <password> [, <class>]]

Response Syntax: (for <mode>=2 and command successful)

+CLCK: <status> [, <class1> [<CR><LF>+CLCK: <status>, <class2> [...]]

Command	Possible responses
AT+CLCK="AO",1,1234 <i>Note :</i>	OK <i>Note : Command valid</i>
AT+CLCK="AO",0,5555 <i>Note :</i>	+CME ERROR: 16 <i>Note : Wrong password</i>
AT+CLCK="AO",0,1234 <i>Note :</i>	OK <i>Note : Command valid</i>

10.2.3 Defined values

<fac>

"AO", "OI", "OX" barring for outgoing calls

"AI", "IR" barring for incoming calls

"AG", "AC", "AB" for all calls barring (<mode>=0 only)

<mode>

0: Unlocks the facility

1: Locks the facility

2: Query status

<class> : see description for +CLCK command (Facility lock) or +CCFC (Call forwarding).

Note : A combination of different classes is **not supported**. It will only result in the activation / deactivation / status request for all classes (7).

The password code is over 4 digits maximum.

29th September 2004

< status >

0 : not active

1 : active

10.3 Modify SS password +CPWD

10.3.1 Description

This command is used by the application to change the supplementary service password.

10.3.2 Syntax

Command Syntax: AT+CPWD=<fac>,<OldPassword>, <NewPassword>

Command	Possible responses
AT+CPWD="AO",1234,5555 <i>Note : Change Call Barring password</i>	OK <i>Note : Password changed</i>
AT+CPWD="AO",1234,5555 <i>Note : Change password</i>	+CME ERROR: 16 <i>Note : Wrong password</i>
AT+CPWD="AO",5555,1234 <i>Note : Change password</i>	OK <i>Note : Password changed</i>

10.3.3 Defined values

<fac>

see +CLCK command with only "P2" facility added (SIM PIN2).

Note : Whatever the facility specified, the change of password applies to all calls barring.

<OldPassword>, <NewPassword>

The password code is over up to 8 digits for P2 facility (4 to 8 digits).

The password code is over up to 4 digits for the other facilities (1 to 4 digits) .

10.4 Call waiting +CCWA

10.4.1 Description

This command allows control of the call waiting supplementary service.

The product will send a +CCWA unsolicited result code when the call waiting service is enabled.

10.4.2 Syntax

Command Syntax: AT+CCWA=<n>, [<mode> [, <class>]]

Response Syntax: (for <mode>=2 and command successful)

+CCWA: <status> [, <class1> [<CR><LF>+CCWA: <status>, <class2> [...]]

Unsolicited result: +CCWA: <number>, <type>, <class> [,<alpha>] (when waiting service is enabled)

Command	Possible responses
AT+CCWA=1,1,1 <i>Note : Enable call waiting for voice calls</i>	OK <i>Note : Command valid</i>
AT+CCWA=1,2 <i>Note : Interrogate call waiting</i>	+CCWA:1,1 OK <i>Note : Call waiting active for voice calls</i>
	+CCWA:"0146290800",145,1,"FREDDY" <i>Note : Number and name of the waiting voice call</i> or +CCWA:"0146290800",145,1,"8023459678FFFF" <i>Note : Number and name of the waiting voice call (UCS2 format)</i>
AT+CCWA=1,0,7 <i>Note : Erase call waiting</i>	OK <i>Note : Command valid</i>
	+CCWA:,,1 <i>Note : voice call waiting (no number)</i>
AT+CCWA?	+CCWA: <n> OK

29th September 2004

AT+CCWA=?	+CCWA: <i>List of supported</i> <n> OK
-----------	---

10.4.3 Defined values

<n> result code presentation status in the TA

0 Disable

1 Enable

<mode> 0 Disable

1 Enable

2 Query status

<type> Type of address byte in integer format (please refer to Rec GSM 04.08 [8] subclause 10.5.4.7)

<class> 1 Voice

2 Data

4 Fax

8 Short Messages

7 All classes (voice, data and fax)

A combination of different classes is **not supported**. It will only result in the activation / deactivation / status request for all classes (7).

<status> 0 not active

1 active

<alpha> optional string type alphanumeric representation of <number> corresponding to the entry found in the ADN or FDN phonebook.

29th September 2004

10.5 Calling line identification restriction +CLIR

10.5.1 Description

This command allows control of the calling line identification restriction supplementary service.

10.5.2 Syntax

Command syntax : AT+CLIR=<n>

Response syntax : +CLIR :<n>,<m> (for AT+CLIR ?)

Command	Possible responses
AT+CLIR=2 <i>Note :</i>	OK <i>Note : Command valid</i>
AT+CLIR ? <i>Note : Ask for current functionality</i>	+CLIR :<n>,<m> OK <i>Note : <n> and <m> as defined here-below</i>

10.5.3 Defined values

<n>: sets the line ID restriction for outgoing calls

- 0: Presentation indicator is used according to the subscription of the CLIR service
- 1: CLIR invocation
- 2: CLIR suppression

<m>: shows the subscriber CLIR status in the network

- 0: CLIR not provisioned
- 1: CLIR provisioned in permanent mode
- 2: Unknown (no network...)
- 3: CLIR temporary mode presentation restricted
- 4: CLIR temporary mode presentation allowed

10.6 Calling line identification presentation +CLIP

10.6.1 Description

This command allows control of the Calling Line Identifier presentation supplementary service. When presentation of the CLI (Calling Line Identifier) is

29th September 2004

enabled (and calling subscriber allows), +CLIP response is returned after every RING (or +CRING) result code.

10.6.2 Syntax

Command syntax : AT+CLIP=<n>

Response syntax :

+CLIP: <n>,<m> (as response to AT+CLIP?)

+CLIP: <number>, <type>[,<subaddr>, <satype>, <alpha>] (for an incoming call, after each RING or +CRING indication)

Command	Possible responses
AT+CLIP=1 <i>Note : Enable CLIP</i>	OK <i>Note : CLIP is enabled</i>
AT+CLIP? <i>Note : Ask for current functionality</i>	+CLIP:<n>,<m> OK <i>Note : <n> and <m> defined as below</i>
	RING <i>Note : Incoming call</i> +CLIP: "0146290800",129,1,,"FRED" <i>Note : Incoming call with number and name presentation</i>
	RING <i>Note : Incoming call</i> +CLIP: "0146290800",129,1,,"8000204212FFFF" " <i>Note : Incoming call with number and name presentation (UCS2 format)</i>
AT+CLIP=0 <i>Note : Disable CLIP presentation</i>	OK <i>Note : Command valid</i>

10.6.3 Defined values

<n>: parameter sets/shows the result code presentation in the TA

0: Disable

1: Enable

<m>: parameter shows the subscriber CLIP service status in the network

0: CLIP not provisioned

29th September 2004

- 1: CLIP provisioned
- 2: Unknown (no network...)

10.7 Connected line identification presentation +COLP

10.7.1 Description

This command allows control of the connected line identification presentation supplementary service – useful for call forwarding of the connected line.

10.7.2 Syntax

Command syntax: AT+COLP=<n>

Response syntax:

+COLP: <n>,<m> (as response to AT+COLP?)

+COLP: <number>,<type> [,<subaddr>, <satype>, <alpha>]

after ATD command, before OK or CONNECT <speed>

Command	Possible responses
AT+COLP=1 <i>Note : Activate COLP</i>	OK <i>Note : Command valid</i>
AT+COLP? <i>Note : Ask for current functionality</i>	+COLP:1,1 OK <i>Note : COLP is enabled and provisioned</i>
ATD146290928; <i>Note : Outgoing call</i>	+COLP:"0146290928",129,,"JOE" or +COLP:"0146290800",129,1,,"80002042 12FFFF" (UCS2 format) OK <i>Note : Connected outgoing line number and name presentation</i>
AT+COLP=0 <i>Note : Deactivate COLP</i>	OK <i>Note : Command valid</i>

10.7.3 Defined values

<n>: parameter sets/shows the result code presentation status in the TA

- 0: Disable
- 1: Enable

29th September 2004

<m>: parameter shows the subscriber COLP service status in the network

0: COLP not provisioned

1: COLP provisioned

2: Unknown (no network)

10.8 Advice of charge +CAOC

10.8.1 Description

This refers to the Advice of Charge supplementary service (GSM 02.24 and GSM 02.86) which enables the subscriber to obtain information on call cost. With <mode>=0, the command returns the current call meter value (CCM) from the ME.

If AOC is supported, the command can also enable unsolicited event reporting on CCM information.

The unsolicited result code +CCCM: <ccm> is sent when the CCM value changes. Deactivation of unsolicited event reporting is performed with the same command.

If AOC is supported, the Read command indicates whether unsolicited reporting is activated or not.

29th September 2004

10.8.2 Syntax

Command syntax : AT+CAOC= <mode>

Command	Possible responses
AT+CAOC=0 <i>Note : Query CCM value</i>	+CAOC: "000A08" OK <i>Note : Display Current Call Meter value (CCM=2568)</i>
AT+CAOC=1 <i>Note : Deactivate unsolicited report of CCM value</i>	OK <i>Note : CCM report deactivated</i>
AT+CAOC=2 <i>Note : Activate unsolicited report of CCM value</i>	OK <i>Note : CCM report activated</i>
AT+CAOC ? <i>Note : Request mode</i>	+CAOC :<mode> OK <i>Note : Display unsolicited report mode (1 or 2)</i>
AT+CAOC=? <i>Note : Request supported modes</i>	+CAOC : (0-2) OK <i>Note : 0,1,2 modes supported</i>

10.8.3 Defined values

<mode>

- 0: query CCM value
- 1: deactivate the unsolicited reporting of CCM value
- 2: activate the unsolicited reporting of CCM value

<ccm> string type; three bytes of the current call meter value in hexadecimal format (e.g. "00001E" corresponds to the decimal value 30); value is in home units and bytes are coded in a similar way as the ACMmax value in SIM.

10.9 Accumulated call meter +CACM

10.9.1 Description

This command resets the Advice of Charge for accumulated call meter value in SIM file EF_{ACM}. The ACM contains the total number of home units for both the current and preceding calls. SIM PIN2 is required to reset the value. If setting fails in an ME error, +CME ERROR: <err> is returned.

29th September 2004

The Read command returns the current value of the ACM.

The ACM value (entered or displayed) is in hexadecimal format with 6 digits.

10.9.2 Syntax

Command syntax : AT+CACM :<pin2 passwd>

Possible response : +CACM : <acm value>

Command	Possible responses
AT+CACM? <i>Note : Request ACM value</i>	+CACM: "000400" OK <i>Note : Display ACM value (ACM=1024)</i>
AT+CACM= 1234 <i>Note : Request ACM reset, real PIN2 is "1234"</i>	OK <i>Note : ACM value is reset</i>
AT+CACM= 0000 <i>Note : Request ACM reset with wrong PIN2 value</i>	+CME ERROR : 16 <i>Note : Incorrect password</i>
AT+CACM ? <i>Note : Request ACM value</i>	+CACM: "000000" OK <i>Note : Display ACM value (ACM = 0)</i>

10.9.3 Defined values:

<pin2 passwd>

string type

<acm value>

string type coded as <ccm> under +CAOC.

29th September 2004

10.10 Accumulated call meter maximum +CAMM

10.10.1 Description

The set command sets the Advice of Charge related to accumulated call meter maximum value in SIM file EF_{ACMmax}. ACMmax contains the maximum number of home units the subscriber is allowed to spend. When ACM (see +CACM) reaches ACMmax, calls are prohibited. SIM PIN2 is required to set the value. If setting fails in an ME error, +CME ERROR: <err> is returned.

The Read command returns the current value of ACMmax.

The ACMmax value (entered or displayed) is in hexadecimal format with 6 digits.

10.10.2 Syntax

Command syntax : AT+CAMM:<ACMmax>,<pin2 passwd>

Command	Possible responses
AT+CAMM="000400",1234 <i>Note : Request ACMmax update, PIN2 is "1234"</i>	OK <i>Note : ACMmax updated to 1024</i>
AT+CAMM="000400",0000 <i>Note : Request ACMmax update, PIN2 is "1234"</i>	+CME ERROR : 16 <i>Note : Incorrect password</i>
AT+CAMM ? <i>Note : Request ACMmax value</i>	+CAMM : "000400" OK <i>Note : ACMmax = 1024</i>

10.10.3 Defined values:

<ACMmax>

string type coded as <ccm> under +CAOC. Value 0 disables ACMmax feature.

<pin2 passwd>

string type

10.11 Price per unit and currency table +CPUC

10.11.1 Description

The set command sets the parameters for Advice of Charge related to price per unit and the currency table in SIM file EFFUCT. PUCT information can be used to convert the home units (as used in +CAOC, +CACM and +CAMM) into

29th September 2004

currency units. SIM PIN2 is required to set the parameters. If setting fails in an ME error, +CME ERROR: <err> is returned.

10.11.2 Syntax

Command syntax : AT+CPUC :<currency>,<ppu>,<pin2 passwd>

Command	Possible responses
AT+CPUC="FFR","0.82",1234 <i>Note : Request Currency and Price per unit update</i>	OK
AT+CPUC="FFR","0.82",1111 <i>Note : Request Currency and PPU update (wrong PIN2)</i>	+ CME ERROR : 16 <i>Note : Incorrect password</i>
AT+CPUC? <i>Note : Request Currency and Price</i>	+CPUC:"FFR","0.82" OK <i>Note : Currency= "FFR" Price per unit= "0.82"</i>

10.11.3 Defined values:

<currency>

string type

<ppu>

string type

<pin2 passwd>

string type

29th September 2004

10.12 Call related supplementary services +CHLD

10.12.1 Description

This command is used to manage call hold and multiparty conversation (conference call). Calls can be put on hold, recovered, released or added to a conversation.

10.12.2 Syntax:

Command	Possible responses
AT+CHLD=<n>	OK <i>Note : if n is within the defined values</i>
AT+CHLD=?	+CHLD: (0-4, 11-17, 21-27) OK

10.12.3 Defined values

<n>

0: Release all held calls or set User Determined User Busy (UDUB) for a waiting call.

1: Release all active calls (if any exist) and accepts the other (held or waiting) call.

1X: Release a specific call *X* (active, held or waiting)

2: Place all active calls (if any exist) on hold and accepts the other (held or waiting) call.

2X: Place all active calls on hold except call *X* with which communication is supported.

3: Adds a held call to the conversation.

4: Connects the two calls and disconnects the subscriber from both calls (Explicit Call Transfer).

29th September 2004

10.13 List current calls +CLCC

10.13.1 Description

This command is used to return a list of current calls.

10.13.2 Syntax:

Command syntax : AT+CLCC

Response syntax: OK (*if no calls are available*)

Else :

+CLCC : <id1>, <dir>, <stat>, <mode>, <mpty> [,<number>, <type> [<alpha>]]

[<CR><LF>

+CLCC: <id2>, <dir>, <stat>, <mode>, <mpty> [,<number>, <type> [<alpha>]][...]]

<CR><LF>

OK

Command	Possible responses
RING <i>Note: Incoming call</i>	
AT+CLCC	+CLCC: 1,1,4,0,0,"0146294079",129 OK
ATA <i>Note: Answering the cal</i>	OK
AT+CLCC	+CLCC: 1,1,1,0,0,"0146294079",129 OK
ATD0146299704; <i>Note: Outgoing call</i>	OK
AT+CLCC <i>Note: Before the phone called is ringing</i>	+CLCC: 1,0,2,0,0,"0146294079",129 OK
AT+CLCC <i>Note: The phone called is ringing</i>	+CLCC: 1,0,3,0,0,"0146294079",129 OK
AT+CLCC <i>Note: The call is being answered</i>	+CLCC: 1,0,0,0,0,"0146294079",129 OK

29th September 2004

10.13.3 Defined values

<idx> integer type, call identification as described in GSM 02.30

<dir> (direction of the call)

0: mobile originated (MO) call

1: mobile terminated (MT) call

<stat> (state of the call):

0: active

1: held

2: dialing (MO call)

3: alerting (MO call)

4: incoming (MT call)

5: waiting (MT call)

<mode> (teleservice) :

0 : voice

1: data

2: fax

9: unknown

<mpty> (multiparty)

0: call is not one of multiparty (conference) call parties

1: call is one of multiparty (conference) call parties

<number> string type phone number in format specified by **<type>**

<type> type of address byte in integer format

<alpha> optional string type alphanumeric representation of **<number>**,

corresponding to the entry found in phonebook. *(for UCS2 format see commands examples +CLIP, +CCWA or +COLP)*

29th September 2004

10.14 Supplementary service notifications +CSSN

10.14.1 Description

This command refers to supplementary service related network initiated notifications.

10.14.2 Syntax:

Command syntax: AT+CSSN= <n>, <m>

When <n>=1 and a supplementary service notification is received after a mobile originated call setup, intermediate result code +CSSI:<code1>[,<index>] is sent before any other MO call setup result codes.

When <m>=1 and a supplementary service notification is received during a call, unsolicited result code +CSSU:<code2>[,<index>[,<number>,<type>]] is sent.

10.14.3 Defined values

<n> (parameter sets/shows the +CSSI result code presentation status) :

- 0 disable
- 1 enable

<m> (parameter sets/shows the +CSSU result code presentation status) :

- 0 disable
- 1 enable

<code1>

- 0 Unconditional call forwarding is active
- 1 Some of the conditional call forwardings are active
- 4 closed User Group call, with CUG <index>
- 5 outgoing calls are barred
- 6 incoming calls are barred
- 7 CLIR suppression rejected

29th September 2004

<code2>

- | | |
|---|--|
| 0 | this is a forwarded call (MT call setup) |
| 1 | closed User Group call, with CUG <index> |
| 2 | call has been put on hold (during a voice call, <number> & <type> fields may be present) |
| 3 | call has been retrieved (during a voice call, <number> & <type> fields may be present) |
| 4 | multiparty call entered (during a voice call, <number> & <type> fields may be present) |
| 5 | call on hold has been released (during a voice call) |
| 7 | call is being connected (alerting) with the remote party in alerting state in Explicit Call Transfer operation (during a voice call) |
| 8 | call has been connected with the other remote party in Explicit Call Transfer operation (during a voice call, <number> & <type> fields may be present) |

<index> Closed User Group index**<number>** String type phone number**<type>** Type of address

10.15 Unstructured supplementary service data +CUSD

10.15.1 Description

The USSD supplementary service is described in GSM 02.90.

It is based on sequences of digits which may be entered by a mobile user with a handset. A sequence entered is sent to the network which replies with an alphanumerical string, for display only, or for display plus request for the next sequence.

This command is used to:

- enable or disable the CUSD indication sent to the application by the product when an incoming USSD is received
- send and receive USSD strings

10.15.2 Syntax :

Command syntax : AT+CUSD = <n> [,<str> [<dcx>]]

29th September 2004

Note : in case of enabled presentation, a +CUSD (as direct answer to a send USSD) is then indicated with :

+CUSD: <m> [,<str>,<dc>]

10.15.3 Defined values

<n>

- 0 Disable the result code presentation
- 1 Enable the result code presentation
- 2 Cancel session (not applicable to read command response)

<m>

- 0 no further user action required (network initiated USSD-Notify, or no further information needed after mobile initiated operation)
- 1 further user action required (network initiated USSD-Request, or further information needed after mobile initiated operation)
- 2 USSD terminated by network
- 4 Operation not supported

<str>: network string (name), converted in the selected character set

<dc> : the data coding scheme received (GSM TS 03.38).

10.15.4 Syntax To send and receive USSD :

Command syntax: AT+CUSD= <n> [,<str> [,<dc>]]

Note : Please, be aware that the send USSD command needs the user to re-enter the <n> parameter !

10.15.5 Defined values To send and receive USSD :

<str> is the USSD string to be sent.

<dc> the default alphabet and the UCS2 alphabet are supported.

When the product sends a USSD, an OK response is first returned, and the intermediate +CUSD indication comes subsequently.

In case of error, a "+CUSD:4" indication is returned.

29th September 2004

10.16 Closed user group +CCUG

10.16.1 Description

The Closed User Group Supplementary Service enables subscribers to form groups with restricted access (both access to and from).

The CUG supplementary service is described in GSM 02.85. This service is provided on prior arrangement with the service provider. Subscription options should be selected at implementation.

The +CCUG command is used to:

- activate/deactivate the control of CUG information for all following outgoing calls,
- select a CUG index,
- suppress outgoing access (OA). OA allows or not a member of a CUG to place calls outside the CUG.
- suppress the preferential CUG. Preferential is the default CUG used by the network when it does not receive an explicit CUG index.

10.16.2 Syntax :

Command syntax: AT+CCUG = <n> [,<index> [<info>]]

10.16.3 Defined values

<n>

- | | |
|---|----------------------------|
| 0 | Disable CUG mode (default) |
| 1 | Enable CUG mode |

<index>

- | | |
|-----|-----------------------|
| 0-9 | CUG index (0 default) |
| 10 | Preferred CUG |

<info>

- | | |
|---|----------------------------------|
| 0 | No information (default) |
| 1 | Suppress OA |
| 2 | Suppress preferential CUG |
| 3 | Suppress OA and preferential CUG |

Remark : to activate the control of the CUG information by call, add [G] or [g] to the ATD command. In this case, index and info values will be used.

11 Data commands

11.1 Using AT Commands during a data connection

To use AT Commands during a data connection (e.g. while the product is in online mode), it is necessary either to switch to offline mode, or to use the specific **+WMUX** command to enable Commands / Data multiplexing.

11.1.1 Switch from online to offline mode

To switch from online mode to offline mode, the “+++” sequence must be sent. Following this, the product gets back to offline mode with an “OK” response, and a AT command can be sent.

Note: the “+++” sequence will only work with the **+ICF** command using one of the following settings:

- 8 data bits, with no parity
- 7 data bits, with even parity

11.1.2 Switch from offline to online mode

See the **ATO** command description.

11.2 Bearer type selection **+CBST**

11.2.1 Description

This command applies to both **outgoing** and **incoming data calls**, but in a different way. For an outgoing call, the two parameters (e.g. **<speed>** and **<ce>**) are meaningful, whereas for an incoming call, only the **<ce>** parameter is used.

Note 1) For incoming calls, if **<ce>** is set to ‘T’ only and the network offers only ‘NT’ or vice versa, then the call is released.

Note 2) Values 2 and 3 for **<ce>** parameter are equivalent to former values 100 and 101. Those values are managed for compatibility purpose, but they shouldn’t be used in new code (2 as former 100, and 3 as former 101).

29th September 2004

11.2.2 Syntax

Command syntax: AT+CBST= <speed>, <name>, <ce>

Command	Possible responses
AT+CBST=? <i>Note : Test command</i>	+CBST: (0-8,65,66,68,70,71),(0),(0-3) OK <i>Note : Data 14,4 kbps not supported</i>
AT+CBST=? <i>Note : Test command</i>	+CBST: (0-8,12,14,65,66,68,70,71,75),(0),(0-3) OK <i>Note : Data 14,4 kbps supported</i>
AT+CBST=7,0,1 <i>Note : Ask for a bearer</i>	OK <i>Note : Bearer supported</i>
AT+CBST? <i>Note : Current values</i>	+CBST:7,0,1 OK <i>Note : Command valid</i>
AT+CBST=81,0,0 <i>Note : Ask for a bearer</i>	+CME ERROR : 4 <i>Note : Bearer not supported</i>

11.2.3 Defined values

<speed>

0 (default)	Autobauding (modem type : none)
1	300 bps (modem type: V.21)
2	1200 bps (modem type: V.22)
3	1200/75 bps (modem type: V.23)
4	2400 bps (modem type: V.22bis)
5	2400 bps (modem type: V.26ter)
6	4800 bps (modem type: V.32)
7	9600 bps (modem type: V.32)
8	Specific
12	9600 bps (modem type: V.34)
14(*)	1400 bps (modem type : V.34)
65	300 bps (modem type: V.110)
66	1200 bps (modem type: V.110)
68	2400 bps (modem type: V.110)
70	4800 bps (modem type: V.110)
71	9600 bps (modem type: V.110)

29th September 2004

75(*): 14400 bps (modem type: V.110)

(*)This speed configures data and fax 14.4 kbps bearers.

<name>

No data compression is provided and only asynchronous modem is supported :
 <name> = 0.

<ce> : Connection element

- 0 Transparent only
- 1(default) Non transparent only
- 2 Transparent preferred
- 3 Non transparent preferred

11.3 Select mode +FCLASS

11.3.1 Description

This command sets the product into a particular operating mode (data or fax).

11.3.2 Syntax

Command syntax: AT+FCLASS= <n>

Command	Possible responses
AT+FCLASS=? <i>Note : Test command</i>	+FCLASS: (0,1) OK <i>Note : Fax class 2 not supported</i>
AT+FCLASS=? <i>Note : Test command</i>	+FCLASS: (0,1,2) OK <i>Note : Fax class 2 supported</i>
AT+FCLASS=0 <i>Note : Data mode requested</i>	OK <i>Note : Command valid</i>
AT+FCLASS=1 <i>Note : Fax class 1 mode requested</i>	OK <i>Note : Command valid</i>
AT+FCLASS? <i>Note : Current value</i>	+FCLASS: 1 OK <i>Note : Command valid</i>

29th September 2004

11.3.3 Defined values

<n>

0: Data

1: Fax class 1

2: Fax class 2

11.4 Service reporting control +CR

11.4.1 Description

This command enables a detailed type of service reporting in the case of **incoming or outgoing data calls**. Before sending the CONNECT response to the application, the product will specify the type of data connection that has been set up.

These report types are :

+CR: ASYNC	For asynchronous transparent
+CR: REL ASYNC	For asynchronous non-transparent

11.4.2 Syntax :

Command syntax : AT+CR=<mode>

Command	Possible responses
AT+CR=0 <i>Note : Extended reports disabled</i>	OK <i>Note : Command valid</i>
AT+CR=1 <i>Note : Extended reports enabled</i>	OK <i>Note : Command valid</i>
AT+CR?	+CR: 1 OK
AT+CR=?	+CR: (0,1) OK

11.4.3 Defined values:

<mode>:

0: disable extended reports

1: enable extended reports

29th September 2004

11.5 Cellular result codes +CRC

11.5.1 Description

This command allows more detailed ring information for an **incoming call** (voice or data). Instead of the string "RING", an extended string is used to indicate which type of call is ringing (e.g. +CRING: VOICE).

These extended indications are:

+CRING: ASYNC	for asynchronous transparent
+CRING: REL ASYNC	for asynchronous non-transparent
+CRING: VOICE	for normal speech.
+CRING : FAX	for fax calls

11.5.2 Syntax :

Command syntax : AT+CRC=<mode>

Command	Possible responses
AT+CRC=0 <i>Note : Extended reports disabled</i>	OK <i>Note : Command valid</i>
AT+CRC=1 <i>Note : Extended reports enabled</i>	OK <i>Note : Command valid</i>
AT+CRC?	+CRC: 1 OK
AT+CRC=?	+CRC: (0,1) OK

11.5.3 Defined values:

<mode>:

0: disable extended reports

1: enable extended reports

11.6 DTE-DCE local rate reporting +ILRR

11.6.1 Description

This parameter controls whether the extended-format "+ILRR:<rate>" information text is transmitted from the DCE to the DTE or not. The <rate> value reported represents the current (negotiated or renegotiated) DTE-DCE speed rate.

If enabled, the intermediate result code is transmitted in an **incoming or outgoing data call**, after any data compression report, and before any final result code (CONNECT).

11.6.2 Syntax

Command syntax : AT+ILRR = <value>

Command	Possible responses
AT+ILRR=0 <i>Note : Local port rate report disabled</i>	OK <i>Note : Command valid</i>
AT+ILRR=1 <i>Note : Local port rate report enabled</i>	OK <i>Note : Command valid</i>
AT+ILRR?	+ILRR: 1 OK
AT+ILRR=?	+ILRR: (0,1) OK

11.6.3 Defined values:

<value>:

0: disable local port rate report

1: enable local port rate report

<rate> can take the following values: 300, 600, 1200, 2400, 4800, 9600, 19200, 38400, 57600, 115200 (kbps).

29th September 2004

11.7 Radio link protocol parameters +CRLP

11.7.1 Description

This command modifies the radio link protocol parameters used for non transparent data transmission.

11.7.2 Syntax

Command syntax: AT+CRLP=<iws>,<mws>,<T1>,<N2>,<ver>

Command	Possible responses
AT+CRLP=? <i>Note : Test command</i>	+CRLP: (0-61),(0-61),(40-255),(1,255),(0) OK <i>Note : V42bis not supported</i>
AT+CRLP=? <i>Note : Test command</i>	+CRLP: (0-61),(0-61),(40-255),(1,255),(0,1) OK <i>Note : V42bis supported</i>
AT+CRLP=61,61,48,6,0 <i>Note : Set new parameters</i>	OK <i>Note : Command valid</i>
AT+CRLP? <i>Note : Current values</i>	+CRLP: 61,61,48,6,0 <i>Note : Command valid</i>

11.7.3 Defined values

<iws> : Down window size, (default is 61)

Range 0 to 61

<mws> : Up window size, (default is 61)

Range 0 to 61

<T1> : Acknowledgement timer in units of 10ms, (default is 48)

Range 40 to 255

<N2> : Retransmission attempts, (default is 6),

Range 1 to 255

<ver> : Version number.

0 : V42bis is not supported.

29th September 2004

1 : V42bis is supported

11.8 Others radio link parameters +DOPT

11.8.1 Description

This Wavecom specific command modifies some supplementary radio link protocol parameters.

11.8.2 Syntax

Command syntax: AT+DOPT=<reset_allowed>,<dtx_allowed>

Command	Possible responses
AT+DOPT=1 <i>Note : Set new parameters (2nd value is the default one)</i>	OK <i>Note : Command valid</i>
AT+DOPT=? <i>Note : Test command</i>	(0,1),(0,1) OK <i>Note : DTX is supported</i>
AT+DOPT=1,1 <i>Note : Set new parameters</i>	OK <i>Note : Command valid</i>
AT+DOPT? <i>Note : Current values</i>	1,1 OK <i>Note : Command valid</i>

11.8.3 Defined values

<reset_allowed>

- 0 Data communication is hung up in case of bad radio link.
- 1 Data communication is held, even in case of bad radio link (**possible loss of data**). Default value

< dtx_allowed >

- 0 Normal mode
- 1 Economic battery mode (not supported by all networks), default value

29th September 2004

11.9 Select data compression %C

11.9.1 Description

This command enables or disables data compression negotiation if this feature is supported by the product.

11.9.2 Syntax

Command syntax : AT%C<n>

Command	Possible responses
AT%C0 <i>Note : Command</i>	OK <i>Note : Feature supported</i>
AT%C2 <i>Note : Command</i>	OK <i>Note : V42bis supported</i>
AT%C? <i>Note : Current value</i>	2 OK <i>Note : Command valid</i>

11.9.3 Defined values

<n>

0 : no compression (default value)

2 : V42bis compression if supported

29th September 2004

11.10 V42 bis data compression +DS

11.10.1 Description

This command enables or disables V.42bis data compression if this feature is supported by the product. Beware that the product only allows the MNP2 protocol.

11.10.2 Syntax

Command syntax : AT+DS=<dir>,<neg>,<P1>,<P2>

Command	Possible responses
AT+DS=? <i>Note : Test command</i>	+DS: (0-3),(0,1),(512-4096),(6-250) OK <i>Note:</i>
AT+DS=3,0,4096,250 <i>Note : Set new parameters</i>	OK <i>Note : Command valid</i>
AT+DS? <i>Note : Current values</i>	+DS: 3,0,4096,250 OK <i>Note : Command valid</i>

11.10.3 Defined values

<dir>: specifies the desired direction(s) of operation of the data compression function; **from the DTE point of view**

- 0 Negotiated ... no compression
- 1 Transmit only
- 2 Receive only
- 3 Both directions, accept any direction (default value)

<neg>: specifies whether or not the DCE should continue to operate if the desired result is not obtained

- 0 Do not disconnect if V.42 bis is not negotiated by the remote DCE as specified in <dir> (default value)
- 1 Disconnect if V.42 bis is not negotiated by the remote DCE as specified in <dir>

<P1 > : specifies the maximum number of dictionary entries that should be negotiated, **(default is 4096)**

Range **512 to 4096**

29th September 2004

< P2 > : specifies the maximum string length to be negotiated, **(default is 20)**.
 Range **6 to 250**

11.11 V42 bis data compression report +DR

11.11.1 Description

This command determines whether or not the use of V42bis is allowed for an **incoming or outgoing data call**, if the feature is provided by the product.

The intermediate result code represents current DCE-DCE data compression type. The format of this result code is as follows:

+DR: NONE	Data compression is not in use
+DR: V42B	Rec. V.42 bis is in use in both directions
+DR: V42B RD	Rec. V.42 bis is in use in receive direction only
+DR: V42B TD	Rec. V.42 bis is in use in transmit direction only

The +DR intermediate result code, if enabled, is issued before the final result code, after the service report control +CR and before the +ILRR intermediate report.

11.11.2 Syntax

Command syntax : AT+DR=<status>

Command	Possible responses
AT+DR=? <i>Note : Test command</i>	+DR: (0,1) OK <i>Note :</i>
AT+DR=1 <i>Note : Reporting enabled</i>	OK <i>Note : Command valid</i>
AT+DR? <i>Note : Current value</i>	+DR: 1 OK <i>Note : Command valid</i>

11.11.3 Defined values

<status> : state of the V42bis enabling

0 : disabled (default value)

29th September 2004

1 : enabled

11.12 Select data error correcting mode \N

11.12.1 Description

This command controls the preferred error correcting mode for a data connection, if the feature is provided by the product. It can only be used for **transparent data transmission**.

If the MNP2 feature is provided, the product authorizes MNP error correction mode.

11.12.2 Syntax

Command syntax : AT\N<n>

Command	Possible responses
AT\N0 <i>Note : no error correction</i>	OK
AT\N? <i>Note : Current value</i>	0 OK <i>Note : Command valid</i>
AT\N4	+CME ERROR: 3

11.12.3 Defined values

<n>

0 : Disables error correction mode (default value)

5 : Selects MNP error correction mode

Note : +E prefixed commands of V.25 ter are not used.

29th September 2004

12 Fax commands

The fax service provided by the product is class 1 compatible. However, only the core commands defined by ITU T.31 are supported. This means that commands such as AT+FAR, +FCC, etc. are not supported.

Autobauding must be enabled to set up the product for fax.

All commands described hereafter will return an ERROR response code if they are not issued during communication.

12.1 Transmit speed +FTM

12.1.1 Description

This command sets the fax transmit speed.

12.1.2 Syntax

Command syntax: AT+FTM=<speed>

Command	Possible responses
AT+FTM=? <i>Note : Test command</i>	(24,48,72,73,74,96,97,98,121,122,145,146) OK <i>Note : Fax 14.4 kbps supported</i>

12.1.3 Defined values

<speed>

24	2400 bps (modem type V.27ter)
48	4800 bps (modem type V.27ter)
72	7200 bps (modem type V.29)
73	7200 bps (long) (modem type V.17)
74	7200 bps (short) (modem type V.17)
96	9600 bps (modem type V.29)
97	9600 bps (long) (modem type V.17)
98	9600 bps (short) (modem type V.17)
121	12000 bps (long) (modem type V.17)
122	12000 bps (short) (modem type V.17)
145	14400 bps (long) (modem type V.17)

29th September 2004

146 14400 bps (short) (modem type V.17)

12.2 Receive speed +FRM

12.2.1 Description

This command sets the fax receive speed.

12.2.2 Syntax

Command syntax: AT+FRM=<speed>

Command	Possible responses
AT+FRM=? <i>Note : Test command</i>	(24,48,72,73,74,96,97,98,121,122,145,146) OK <i>Note : Fax 14.4 kbps supported</i>

12.2.3 Defined values

The speed values are identical to those of the +FTM command (*see 12.1*).

12.3 HDLC transmit speed +FTH

12.3.1 Description

This command sets the fax transmit speed, using the HDLC protocol.

12.3.2 Syntax

Command syntax: AT+FTH=<speed>

Command	Possible responses
AT+FTH=? <i>Note : Test command</i>	(3) OK <i>Note :</i>

12.3.3 Defined values

<speed>

3 : V.21 channels 300 bps.

29th September 2004

12.4 HDLC receive speed +FRH

12.4.1 Description

This command sets the fax receive speed, using the HDLC protocol.

12.4.2 Syntax

Command syntax: AT+FRH=<speed>

Command	Possible responses
AT+FRH=? <i>Note : Test command</i>	(3) OK <i>Note :</i>

12.4.3 Defined values

<speed>

3 : V.21 channels 300 bps.

12.5 Stop transmission and wait +FTS

12.5.1 Description

This command stops transmission for the specified period.

12.5.2 Syntax

Command syntax: AT+FTS=<n>

Command	Possible responses
AT+FTS=? <i>Note : Test command</i>	(0-255) OK <i>Note :</i>
AT+FTS=50 <i>Note : Stops transmission and waits for 0.5s</i>	OK <i>Note : Command valid</i>

12.5.3 Defined values

<n> : silence period (unit is 10 ms).

29th September 2004

12.6 Receive silence +FRS

12.6.1 Description

This command causes the modem to stop listening to the network and report back to the DTE after the specified period.

It is aborted if any character is received from the application.

12.6.2 Syntax

Command syntax: AT+FRS=<n>

Command	Possible responses
AT+FRS=? <i>Note : Test command</i>	(0-255) OK <i>Note :</i>
AT+FRS=50 <i>Note : Stops transmission and waits for 0.5s</i>	OK <i>Note : Command valid</i>

12.6.3 Defined values

<n> : no-listening period (units is 10 ms).

12.7 Setting up the PC fax application:

The recommended fax application is *Delrina WinFax v8.0*.

It should be configured as follows (menu Setup/Fax Modem Setup):

- Port: any com
- Model: Generic Class 1 (hardware flow control). A generic class 1 with software flow control can also be selected.
- Init: default string is suitable for the product
- Reset: default string is suitable for the product
- Maximum Transmit Rate: 9600 baud (if higher, rate will be automatically cut back to 9600 baud).

Other settings are of no relevance for the GSM unit : they can be modified.

13 Fax class 2 commands

If the feature is supported, the commands +FDT, +FDR, +FET, +FPTS and +FK must be used during call only.

The other commands, +FBOR, +FBUF, +FCQ, +FCR, +FDCC, +FDIS, +FLID and +FPHCTO, cannot be used during call.

13.1 Transmit Data +FDT

13.1.1 Description :

This command prefixes data transmission.

13.1.2 Syntax

Command syntax: AT+FDT

13.1.3 Defined values

No parameter

13.2 Receive Data +FDR

13.2.1 Description

This command initiates data reception.

13.2.2 Syntax

Command syntax : AT+FDR

13.2.3 Defined values

No parameter

29th September 2004

13.3 Transmit page punctuation +FET

13.3.1 Description

This command punctuates page and document transmission after the +FDT command. It indicates that the current page is complete, and if there are additional pages to send.

13.3.2 Syntax

Command syntax: AT+FET=<ppm>

The remote station should respond with +FPTS:<ppr>

13.3.3 Defined values

<ppm>

- 0 Another page next, same document
- 1 Another document next
- 2 No more pages or documents
- 3 Another partial page next
- 4 Another page, procedure interrupt
- 5 Another document, procedure interrupt
- 6 All done, procedure interrupt

13.4 Page transfer status parameters +FPTS

13.4.1 Description

This command sets post page transfer response.

13.4.2 Syntax

Command syntax: AT+FPTS=<ppr>

13.4.3 Defined values

<ppr>

- 1 Page good
- 2 Page bad ; retry requested
- 3 Page good ; retrain requested
- 4 Page bad ; interrupt requested

5 Page good ; interrupt requested

13.5 Terminate Session +FK

13.5.1 Description

This command causes the product to terminate the session.

13.5.2 Syntax

Command syntax: AT+FK

13.5.3 Defined values

No parameter

13.6 Page transfer bit order +FBOR

13.6.1 Description

This command sets the bit order for negotiation and fax page transfer. The order is related to the bit order on radio link.

13.6.2 Syntax

Command syntax: AT+FBOR=<n>

Command	Possible responses
AT+FBOR=? <i>Note : Test command</i>	(0-3) OK <i>Note :</i>

13.6.3 Defined values

<n>	Bit order for negotiation	Bit order for page transfer
0(default)	Same	Same
1	Same	Reverse
2	Reverse	Same
3	Reverse	Reverse

29th September 2004

13.7 Buffer size report +FBUF

13.7.1 Description

This command requests the size of the exchange buffer between the modem and the fax application.

Note : Only the read command is supported.

13.7.2 Syntax

Command syntax : AT+FBUF

Command	Possible responses
AT+FBUF? <i>Note : Current value</i>	1024 OK <i>Note : Command valid</i>

13.7.3 Defined values

No parameter

13.8 Copy quality checking +FCQ

13.8.1 Description

This command controls Copy Quality checking for receiving faxes.

13.8.2 Syntax

Command syntax : AT+FCQ=<n>

Command	Possible responses
AT+FCQ=? <i>Note : Test command</i>	(0) OK <i>Note :</i>

13.8.3 Defined values

<n>

0 : default value, the only supported

29th September 2004

13.9 Capability to receive +FCR

13.9.1 Description

This commands controls the capability of the modem to accept incoming faxes.

13.9.2 Syntax

Command syntax: AT+FCR=<n>

Command	Possible responses
AT+FCR=?	(0,1)
<i>Note : Test command</i>	OK
	<i>Note :</i>

13.9.3 Defined values

<n>

- 0 The modem will not accept incoming faxes.
- 1 The modem will accept incoming faxes (default value).

29th September 2004

13.10 Current sessions parameters +FDIS

13.10.1 Description

This command allows the DTE to parameter the capabilities used for the current session.

13.10.2 Syntax

Command syntax: AT+FDIS=<vr>,
,<wd>,<ln>,<df>,<ec>,<bf>,<st>

Command	Possible responses
AT+FDIS=? <i>Note :</i>	(0,1),(0-5),(0-2),(0-2),(0-3),(0),(0),(0-7) OK <i>Note : Fax ECM not supported Fax 14,4 kbps supported</i>
	(0,1),(0-3),(0-2),(0-2),(0-3),(0),(0),(0-7) OK <i>Note : Fax ECM not supported Fax 14,4 kbps not supported</i>

13.10.3 Defined values

This command accepts eight numeric parameters (of the T30 standard).

<vr>: Vertical Resolution,

- 0 Normal: 98 lpi (default value)
- 1 Fine: 196 lpi

: Bit Rate,

- 0 2400 bps (modem type V.27 ter)
- 1 4800 bps (modem type V.27 ter)
- 2 7200 bps (modem type V.29)
- 3 9600 bps (modem type V.29, V.17). Default value if 14,4 kbps data feature IS NOT supported.
- 4(*) 12000 bps (modem type V.33, V.17)
- 5(*) 14400 bps (modem type V.33, V.17). Default value if 14,4 kbps data feature IS supported.

(*) Only when product supports 14,4 kbps data feature

29th September 2004

<wd>: Page Width,

- 0 1728 pixels in 215 mm (default value)
- 1 2048 pixels in 255 mm
- 2 2432 pixels in 303 mm

<ln>: Page Length,

- 0 A4, 297 mm
- 1 B4, 364 mm
- 2 Unlimited (default value)

<df> : Data Compression Format,

- 0 1-D modified Huffman (default value)
- 1 2-D modified read
- 2 2-D uncompressed mode
- 3 2-D modified modified read

<ec> : Error Correction,

- 0 : Disable Fax ECM. Default value if fax ECM feature IS NOT supported.
- 1(*) : Enable Fax ECM, 64 bytes/frame
- 2(*) : Enable Fax ECM, 256 bytes/frame. Default value if fax ECM feature IS supported.

(*) Only when product supports fax Error Correction Mode feature

<bf> : Binary File Transfer,

Only **<bf>** : 0 is supported.

29th September 2004

<st> : Scan Time per line,

<st>	Description if <vr>=0	Description if <vr>=1
0 (default)	0 ms	0 ms
1	5 ms	5 ms
2	10 ms	5 ms
3	10 ms	10 ms
4	20 ms	10 ms
5	20 ms	20 ms
6	40 ms	20 ms
7	40 ms	40 ms

29th September 2004

13.11 DCE capabilities parameters +FDCC

13.11.1 Description

This command allows the DTE to parameter the capabilities used for any session.

13.11.2 Syntax

Command syntax: AT+FDCC=<vr>,
,<wd>,<ln>,<df>,<ec>,<bf>,<st>

Command	Possible responses
AT+ FDCC=? <i>Note : Test command</i>	(0,1),(0-5),(0-2),(0-2),(0-3),(0-2),(0),(0-7) OK <i>Note : Fax ECM supported</i> <i>Fax 14,4 kbps supported</i>
	(0,1),(0-5),(0-2),(0-2),(0-3),(0),(0),(0-7) OK <i>Note : Fax ECM not supported</i> <i>Fax 14,4 kbps supported</i>
	(0,1),(0-3),(0-2),(0-2),(0-3),(0-2),(0),(0-7) OK <i>Note : Fax ECM supported</i> <i>Fax 14,4 kbps not supported</i>
	(0,1),(0-3),(0-2),(0-2),(0-3),(0),(0),(0-7) OK <i>Note : Fax ECM not supported</i> <i>Fax 14,4 kbps not supported</i>

13.11.3 Defined values

The parameters and default values are the same as for the +FDIS command (see 13.10.3).

29th September 2004

13.12 Local ID string +FLID

13.12.1 Description

This command allows the local ID string to be defined.

13.12.2 Syntax

Command syntax: AT+FLID="<string>"

Command	Possible responses
AT+FLID=?	(20),(32-127)
<i>Note : Test command</i>	OK

13.12.3 Defined values

<string>

The string has a limited size of 20 characters, and accepts any characters between 32 and 127 as ASCII codes..

13.13 Page transfer timeout parameter +FPHCTO

13.13.1 Description

This command sets the time interval during which the modem expects another page before it assumes there are no more pages and aborts.

13.13.2 Syntax

Command syntax: AT+FPHCTO=<n>

Command	Possible responses
AT+FPHCTO=?	(0-255)
<i>Note : Test command</i>	OK

13.13.3 Defined values

<n> : waiting period for another page in seconds.

Range : 0 to 255, default value is 30.

29th September 2004

13.14 Fax Class 2 indication messages

The following messages are used to indicate DCE Responses. They are used in communication only.

+FCON:

This response indicates connection with a fax machine.

**+FDCS <vr>,
,<wd>,<ln>,<df>,<ec>,<bf>,<st>:**

This response reports current session capabilities. The parameters are the same than those of AT+FDIS command (see 0).

**+FDIS <vr>,
,<wd>,<ln>,<df>,<ec>,<bf>,<st>:**

This response reports remote capabilities. The parameters are the same than those of AT+FDIS command (see 0).

<vr>

Combinations of the following values are also allowed.

<vr>	Coding
0x01	R8 × 7.7 l/mm, Fine (196 lpi)
0x02	R8 × 15.4 l/mm
0x04	R16 × 15.4 l/mm
0x08	200 dpi × 100 l/25.4 mm
0x10	200 dpi × 200 l/25.4 mm
0x20	200 dpi × 400 l/25.4 mm
0x40	300 dpi × 300 l/25.4 mm

+FCFR:

This response indicates confirmation to receive.

+FTSI "<string>":

This response reports the received transmit station ID string.

+FCSI "<string>":

This response reports the received called station ID string.

+FPTS <ppr>:

This response reports received page transfer status. The parameter is the same than the one of AT+FPTS command (see 13.4).

+FET <ppm>:

This response reports post page message response. The parameter is the same than the one of AT+FET command (see 13.2.3).

+FHNG <cause>:

This response reports the hang-up cause. It indicates that the call has been terminated.

29th September 2004

<cause>

0:	Normal	end	of	connection.
10:	Unspecified	transmit	phase	A error.
20:	Unspecified	transmit	phase	B error.
40:	Unspecified	transmit	phase	C error.
50:	Unspecified	transmit	phase	D error.
70:	Unspecified	receive	phase	B error.
90:	Unspecified	receive	phase	C error.
100:	Unspecified receive phase D error.			

14 V24-V25 commands

14.1 Fixed DTE rate +IPR

14.1.1 Description

This commands specifies the data rate at which the DCE will accept commands.

Notes :

- Autobauding is supported (operating from 2400 to 57600 baud).
- Autobauding is supported only when framing is set to 8N1. Other framings such as 7E1 are not supported.
- Any AT command issued by the DTE must start with both capital 'A' and 'T' (or '/') or both lower case 'a' and 't' (or '/'), otherwise the DCE may return some garbage characters and become desynchronized. Should this happen, the DTE simply issues 'AT\r' (at 2400 or 4800 bauds) once or twice or just 'AT' (at 9600 bauds) to resynchronize the modem.
- The DTE waits for 1ms after receiving the last character of the AT response (which is always '\n' or 0x0A) to send a new AT command at either the same rate or a new rate. Should this delay be ignored, the DCE can become desynchronised. Once again, sending 'AT\r' once or twice or just 'AT' causes the DCE to recover.

Caution:

when starting up, if autobauding is enabled and no AT command has yet been received, the product sends all unsolicited responses (like RING) at 9600 bauds.

29th September 2004

14.1.2 Syntax

Command syntax : AT+IPR=<rate>

Command	Possible responses
AT+IPR? <i>Note :</i>	+IPR: 9600 OK <i>Note : Current rate is 9600 bps</i>
AT+IPR=? <i>Note :</i>	+IPR: (0,2400,4800,9600,19200,38400,57600),(300,600,1200,115200) OK <i>Note : Possible values, according to V25 ter Recommendation: the first set of values indicates the range of auto-detectable baud rates (including 0). The second set of values indicates the baud rates supported by the DCE but not auto-detectable.</i>
AT+IPR=38400 <i>Note :</i>	OK <i>Note : Disable autobauding and set rate to 38400 bps</i>
AT+IPR=0 <i>Note :</i>	OK <i>Note : Enable autobauding</i>

14.1.3 Defined values

<rate> : baud rates that can be used by the DCE

- 0 (enables autobauding)
- 300
- 600
- 1200
- 2400
- 4800
- 9600
- 19200
- 38400
- 57600
- 115200

29th September 2004

14.2 DTE-DCE character framing +ICF

14.2.1 Description

This command is used to determine the local serial port start-stop (asynchronous) character framing used by the DCE.

14.2.2 Syntax

Command syntax: AT+ICF= <format>[, <parity>]

Command	Possible responses
AT+ICF? <i>Note :</i>	+ICF: 3,4 OK <i>Note : Current values</i>
AT+ICF=? <i>Note :</i>	+ICF: (1-6),(0-4) OK <i>Note : Possible values</i>
AT+ICF=2,0 <i>Note :</i>	OK <i>Note : New values</i>

14.2.3 Defined values:

<format>

0 : Autodetect (*not supported*)

1 : 8 Data 2 Stop (*supported*)

<parity> parameter is ignored.

2 : 8 Data 1 Parity 1 Stop (*supported*)

if no <parity> provided, 3 is used by default as <parity> value.

3 : 8 Data 1 Stop (*supported*)

<parity> parameter is ignored.

4 : 7 Data 2 Stop (*supported*)

<parity> parameter is ignored.

5 : 7 Data 1 Parity 1 Stop (*supported*)

if no <parity> provided, 3 is used by default as <parity> value.

6 : 7 Data 1 Stop (*supported*)

<parity> parameter is ignored.

<parity>

 confidential ©

Page : 207 / 460

This document is the sole and exclusive property of WAVECOM. Not to be distributed or divulged without prior written agreement. Ce document est la propriété exclusive de WAVECOM. Il ne peut être communiqué ou divulgué à des tiers sans son autorisation préalable.

29th September 2004

- 0 : Odd (*supported*)
- 1 : Even (*supported*)
- 2 : Mark (*supported*)
- 3 : Space (*supported*)
- 4 : None (*supported*)

Notes :

- Setting a character framing different from 8N1 will disable autobauding if it was activated. Setting it back to 8N1 **will not** re-enable autobaud.
- Setting the framing to 8N1 will let the autobauding enabled, if it was already enabled (implying framing was already 8N1).

14.3 DTE-DCE local flow control +IFC

14.3.1 Description

This command is used to control the operation of local flow control between the DTE and DCE.

14.3.2 Syntax

Command syntax : AT+IFC=<DCE_by_DTE>,<DTE_by_DCE>

Command	Possible responses
AT+IFC? <i>Note :</i>	+IFC: 2,2 OK <i>Note : Current values</i>
AT+IFC=? <i>Note :</i>	+IFC: (0,2),(0,2) OK <i>Note : Possible values</i>
AT+IFC=0,0 <i>Note :</i>	OK <i>Note : New values</i>

29th September 2004

14.3.3 Defined values

< DCE_by_DTE >

0 : none *(supported)*1 : Xon/Xoff local circuit 103 *(not supported)*2 : RTS *(supported)*3 : Xon/Xoff global on circuit 103 *(not supported)***Important note:**

when this parameter is set to 2 (DTE invokes flow control through RTS) DCE behaviour is as follows:

If the DCE has never detected RTS in the high (or ON) condition since startup, then it ignores RTS (assuming this signal is not connected).

As soon as the DCE detects RTS high the signal acts on it. Therefore subsequent RTS transition to OFF will prevent the DCE from sending any further data in both online and offline modes.

This behaviour allows the user to use the default settings (hardware flow control) and leave RTS disconnected. In the case where RTS is connected and is high at least once, it acts on the DCE.

< DTE_by_DCE >

0	:		none	<i>(supported)</i>
1	:	Xon/Xoff	circuit 104	<i>(not supported)</i>
2	:	CTS <i>(supported)</i>		

When this parameter is set to 0 (none) then CTS is kept high all the time.

14.4 Set DCD signal &C**14.4.1 Description**

This commands controls the Data Carrier Detect (DCD) signal.

29th September 2004

Note: Wavecom products slightly differ from V25ter Recommendation. DCD signal ("Circuit 109") is turned ON at the same time the CONNECT message is sent, whereas the specification states the DCD should be turned ON after the CONNECT message was received.

14.4.2 Syntax

Command syntax : AT&C<n>

Command	Possible responses
AT&C0 <i>Note : DCD always on</i>	OK <i>Note : Command valid</i>
AT&C1 <i>Note : DCD matches state of the remote modem's data carrier</i>	OK <i>Note : Command valid</i>

14.4.3 Defined values:

<n>

0 : DCD always on

1 : DCD matches state of the remote modem's data carrier

14.5 Set DTR signal &D

14.5.1 Description

This commands controls the Data Terminal Ready (DTR) signal.

14.5.2 Syntax

Command syntax : AT&D<n>

Command	Possible responses
AT&D0 <i>Note : The DTR signal is ignored</i>	OK <i>Note : Command valid</i>
AT&D1 <i>Note : Modem switches from data to command mode when DTR switches from ON to OFF</i>	OK <i>Note : Command valid</i>
AT&D2 <i>Note : Upon DTR switch from ON to OFF, the call is released</i>	OK <i>Note : Command valid</i>

29th September 2004

14.5.3 Defined values:

<n>

0 : The DTR signal is ignored

1 : Modem switches from data to command mode when DTR switches from ON to OFF

2 : Upon DTR switch from ON to OFF, the call is released

14.6 Set DSR signal &S**14.6.1 Description**

This commands controls the Data Set Ready (DSR) signal.

14.6.2 Syntax

Command syntax : AT&S<n>

Command	Possible responses
AT&S0 <i>Note : DSR always on</i>	OK <i>Note : Command valid</i>
AT&S1 <i>Note : DSR off in command mode, DSR on in data mode</i>	OK <i>Note : Command valid</i>

14.6.3 Defined values:

<n>

0 : DSR always on

1 : DSR off in command mode, DSR on in data mode

14.7 Back to online mode O**14.7.1 Description**

If a connection has been established and the ME is in command mode, this command allows you to return to online data mode.

29th September 2004

14.7.2 Syntax

Command syntax : ATO

Command	Possible responses
ATO <i>Return from offline mode to online mode</i>	OK

14.7.3 Defined values

No parameter

14.8 Result code suppression Q**14.8.1 Description**

This command determines whether the mobile equipment sends result codes or not

14.8.2 Syntax

Command syntax : ATQ<n>

Command	Possible responses
ATQ0 <i>Note : DCE transmits result codes</i>	OK <i>Note : Command valid</i>
ATQ1 <i>Note : Result codes are suppressed and not transmitted</i>	<i>Note : No response</i>

14.8.3 Defined values

<n>

0 : DCE transmits result codes

1 : Result codes are suppressed and not transmitted

29th September 2004

14.9 DCE response format V

14.9.1 Description

This command determines whether the DCE response format uses or not the header characters <CR><LF>, and the result codes are provided as numeric or verbose.

14.9.2 Syntax

Command syntax : ATV<n>

Command	Possible responses
ATV0 <i>Note : DCE transmits limited headers and trailers and numeric result codes</i>	0 <i>Note : Command is valid (0 means OK)</i>
ATV1 <i>Note : DCE transmits full headers and trailers and verbose response text</i>	OK <i>Note : Command valid</i>

14.9.3 Defined values

	<n>=0	<n>=1
Information responses	<text><CR><LF>	<CR><LF> <text><CR><LF>
Result codes	<numeric code><CR>	<CR><LF> <verbose code><CR><LF>

14.10 Default configuration Z

14.10.1 Description

This command restores the configuration profile. Any call is released.

29th September 2004

14.10.2 SyntaxCommand syntax : ATZ

Command	Possible responses
ATZ	Ok
<i>Note :</i>	<i>Note : Command valid</i>

14.10.3 Defined values

No parameter

14.11 Save configuration &W**14.11.1 Description**

This commands writes the active configuration to a non-volatile memory (EEPROM). Description of the stored parameters is given in appendix Parameters storage (§19.10)

14.11.2 SyntaxCommand syntax : AT&W

Command	Possible responses
AT&W	OK
<i>Note : Writes current configuration to EEPROM</i>	<i>Note : Command valid</i>

14.11.3 Defined values

No parameter

14.12 Auto-tests &T**14.12.1 Description**

This command allows to trigger various auto-tests.

29th September 2004

14.12.2 Syntax

Command syntax : AT&T<n>

Command	Possible responses
AT&T0 <i>Note : Perform software auto-tests</i>	OK <i>Note : No software problem detected, all checksums are correct</i>
AT&T1 <i>Note : Do the audio loop test (close)</i>	OK <i>Note : Command valid</i>
AT&T2 <i>Note : Stop the audio loop test (open)</i>	OK <i>Note : Command valid</i>

14.12.3 Defined values

<n>

0 : Perform software auto-tests

The response will be OK if no software problem is detected (EEPROM, RAM and ROM checksums), otherwise a simple ERROR response is sent.

1 : Do the audio loop test (close)

This is used to validate the audio loop (microphone to speaker).

2 : Stop the audio loop test (open)

This is used to validate the audio loop (microphone to speaker).

14.13 Echo E

14.13.1 Description

This command is used to determine whether the modem echoes characters received by an external application (DTE) or not.

14.13.2 Syntax

Command syntax : ATE<n>

Command	Possible responses
ATE0 <i>Note : Characters are not echoed</i>	OK <i>Note : Done</i>
ATE1 <i>Note : Characters are echoed</i>	OK <i>Note : Done</i>

29th September 2004

14.13.3 Defined values

<n>

0 : Characters are not echoed

1 : Characters are echoed

14.14 Restore factory settings &F**14.14.1 Description**

This command is used to restore the factory settings from EEPROM.

It only restores the parameters that can be found in table 19.10 (Parameters storage) with AT&F column checked. Those parameters are restored in RAM and in E2P, overwriting the profile set with AT&W.

14.14.2 SyntaxCommand syntax : AT&F[<n>]

Command	Possible responses
AT&F	OK
<i>Note : Ask for restoring the factory settings</i>	<i>Note : Done</i>
AT&F0	OK
<i>Note : idem</i>	<i>Note : Done</i>

14.14.3 Defined values

<n>

0 : restore factory setting

No other value supported

14.15 Display configuration &V**14.15.1 Description**

This command is used to display the modem configuration.

14.15.2 SyntaxCommand syntax : AT&V<n>

29th September 2004

The parameters displayed are the following :

Q:val1, V:val2, S0:val3, S2:val4, S3:val5, S4:val6, S5:val7,
 +CR:val8, +CRC:val9, +CMEE:val10, +CBST:val11,
 +SPEAKER:val12, +ECHO:val13, &C:val14, &D:val15, %C:val16
 +IPR:val17, +ICF:val18, +IFC:val19

Command	Possible responses
AT&V	Q:0 V:1 S0:000 S2:043 S3:013 S4:010 S5:008 +CR:0 +CRC:0 +CMEE:0 +CBST:0,0,1 +SPEAKER:0 +ECHO:0,0 &C:1 &D:2 %C:0 +IPR:9600 +ICF:3,4 +IFC:2,2 OK Note : Done For Echo the first value corresponds to Echo cancellation 1.
Note : Display active parameters in RAM	

14.15.3 Defined values

<n>

- 0 Display the modem configuration in RAM. (default value if no parameter provided)
- 1 Display the modem configuration in EEPROM.
- 2 Display the modem factory configuration.

29th September 2004

14.16 Request identification information I

14.16.1 Description

This command causes the product to transmit one or more lines of specific information text.

14.16.2 Syntax

Command syntax : ATI<n>

Command	Possible responses
ATIO <i>Note : Manufacturer and model identifications</i>	WAVECOM MODEM 900P OK <i>Note : GSM 900 MHz primary band</i>
ATI3 <i>Note : Revision identification</i>	440_09gm.Q2406A 1266500 020503 17:06 OK <i>Note : Software release 4.40, generated on the 05th of February 2003</i>
ATI6 <i>Note : Modem data features</i>	DATA RATES: AUTOBAUD,300,1200,1200/75,2400,480 0,9600,14400 DATA MODES : T/NT,ASYNCHRONOUS FAX CLASS 1,2 OK <i>Note : Done</i>
ATI7 <i>Note : Modem voice features</i>	SPEECH CODINGS: FR,EFR,HR,AMR OK <i>Note : Done</i>

14.16.3 Defined values

<n>

- 0 Display manufacturer followed by model identification. (equivalent to +CGMI and +CGMM, refer to these commands for more precisions).
- 3 Display revision identification (equivalent to +CGMR).
- 4 Display modem configuration in RAM (equivalent to &V0).
- 5 Display modem configuration in EEPROM (equivalent to &V1).

29th September 2004

- 6 Display modem data features. Lists the supported data rates, data modes, and fax classes.
- 7 Display modem voice features.
- Other values "OK" string is sent back.

14.17 Data / Commands Multiplexing +WMUX

14.17.1 Description

This **specific** command allows to manage the data / AT commands multiplexing mode. See appendix 19.13 for the Data / Commands multiplexing protocol description.

14.17.2 Syntax

Command syntax AT+WMUX=<mode>

Command	Possible responses
AT+WMUX=?	+WMUX: (0-1) OK
AT+WMUX?	+WMUX: 0 OK <i>Note : Data / Commands multiplexing disabled.</i>
AT+WMUX=1 <i>Note : Enable Data / Commands multiplexing.</i>	OK

14.17.3 Defined values

<mode>

- 0: Multiplexing disabled. When the product is online (data communication in progress), no AT command can be used (default).
- 1: Multiplexing enabled. Data flows and AT commands are multiplexed while in online mode (data communication in progress).

15 Specific AT commands

15.1 Cell environment description +CCED

15.1.1 Description

This command can be used by the application to retrieve the parameters of the main cell and of up to six neighbouring cells.

There are two possible methods for the external application to ascertain these cell parameters :

- on request by the application or
- automatically by the product every 5 seconds.

Automatic mode is not supported during registration.

15.1.2 Syntax

Command syntax: AT+CCED=<mode>[, <requested dump>]

Command	Possible responses
AT+CCED=0 <i>Note: last request was AT+CCED=0,3 (main cell and neighbors 1 to 6): you can see MCC,MNC sequences (here 208,20)</i>	+CCED:208,20,0002,0418,37,706,24,,,0 ,,0,208,20,0006,989b,37,835,20,208,2 0,0002,02a9,37,831,12,208,20,0101,79 66,34,818,13,208,20,0006,9899,39,713 ,9,208,20,0002,0a72,33,711,12,208,20, 0101,03fb,36,824,10,1 OK
AT+CCED=0,1 <i>Note : Only Main cell request</i>	+CCED:208,20,0002,0418,37,706,25,,,0 ,,0 OK
AT+CCED=0,1 <i>Note: Call in progress : RXLev and RXQual are empty, RxLevFull, RxLevSub, RxQualFull and RxQualSub have data.</i>	+CCED:208,10,189C,,19,85,,31,32,,0,0, OK

29th September 2004

15.1.3 Defined values

<mode>

- 0 : One shot requested
- 1 : Automatic shots requested
- 2 : Stop automatic shots

<requested dump>

1 : Main Cell :

- if the Cell Identity is available

MCC, MNC, LAC, CI, BSIC, BCCH Freq (absolute), RxLev, RxLev Full, RxLev Sub, RxQual, RxQual Full, RxQual Sub, Idle TS

- if the Cell Identity is not available

MCC, MNC, LAC,, BSIC, BCCH Freq (absolute), RxLev, RxLev Full, RxLev Sub, RxQual, RxQual Full, RxQual Sub, Idle TS

2 : Neighbour1 to Neighbour6 :

- if the Cell Identity is available

MCC, MNC, LAC, CI, BSIC, BCCH Freq (absolute), RxLev

- if the Cell Identity is not available

MCC, MNC, LAC,, BSIC, BCCH Freq (absolute), RxLev

4 : Timing Advance

8 : Main cell RSSI indications (RxLev), in a range from 0 to 31

Notes:

- The response for the requested dump 1, 2 and 4 will be:

+CCED :<value1>, ... , <valuen>

OK

where <value> is the ASCII string of the values (in decimal form except the LAC and CI values which are in hexadecimal form) of the parameters. If a field cannot be measured – or is meaningless – the parameter is not filled in, and two consecutive commas are sent.

- The response for the requested dump 8 will be a +CSQ response and not a +CCED response. The 07.07 format for +CSQ is respected. The <ber> is not evaluated by this command, so the <ber> value will always be 99.

+CSQ :<rss>, 99

OK

When automatic shots are selected, this +CSQ response is sent every time the <rss> measured by the product changes. Automatic shots are

29th September 2004

supported in idle mode and during communication. The activation or deactivation of this flow (8) does not affect the other flows.

- In idle mode, only RxLev measurements (on the main cell and on the neighboring cells) are made.
- Combination of the requested dump is supported (addition of the values 1, 2, 4 and 8):

Value	Requested dump	Value	Requested dump
1	+CCED response: Main Cell only	9	+CSQ response, then +CCED response with Main Cell only
2	+CCED response: Neighbors 1 to 6	10	+CSQ response, then +CCED response with Neighbors 1 to 6
3	+CCED response: Main Cell, then Neighbors 1 to 6	11	+CSQ response, then +CCED response with Main Cell, then Neighbors 1 to 6
4	+CCED response: Timing Advance only	12	+CSQ response, then +CCED response with Timing Advance only
5	+CCED response: Main Cell, then Timing Advance	13	+CSQ response, then +CCED response with Main Cell, then Timing Advance
6	+CCED response: Neighbors 1 to 6, then Timing Advance	14	+CSQ response, then +CCED response with Neighbors 1 to 6, then Timing Advance
7	+CCED response: Main Cell, then its Timing Advance, then Neighbors 1 to 6, with each Timing Advance inserted between cells results	15	+CSQ response, then +CCED response with Main Cell, then its Timing Advance, then Neighbors 1 to 6, with each Timing Advance inserted between cells results
8	+CSQ response : Main Cell RSSI indications	No value	Last value used for a CCED request, or 15

- If **<requested dump>** parameter is not provided, the one of the last +CCED command will be used, or 15 (default value).
- Values of MCC/MNC are set to 0 in the case of "No service".

29th September 2004

15.2 General Indications +WIND

15.2.1 Description

Wavecom has introduced a general mechanism to send unsolicited non-standardized indications to the application. These indications are:

- indication of a physical change on the SIM detect pin from the connector (meaning SIM inserted, SIM removed)
- indication during mobile originated call setup that the calling party is ringing.
- Indication of the availability of the product to receive AT commands after boot.
- NITZ indication (Network Information and Time Zone).

For each indication, a "bit flow" has to be indicated.

15.2.2 Syntax:

Command syntax: AT+WIND= <IndLevel >

Command	Possible responses
AT+WIND?	+WIND: 0 OK
AT+WIND=255	OK
<i>Note: The SIM has been removed</i>	+WIND: 0 <i>Note: The SIM presence pin has been detected as "SIM removed"</i>
<i>Note: The SIM has been inserted</i>	+WIND: 1 <i>Note: The SIM presence pin has been detected as "SIM inserted"</i>
<i>Note: The network service is available for an emergency call</i>	+WIND: 7
<i>Note: The initialization has been completed</i>	+WIND: 4
<i>Note: The modem received a NITZ information message</i>	+WIND: 15,1,"Cingular Extend",2,"Cingular",3,"+08",4,"03/14/27,16:59:48+08",5,"123456",6,"2"

The AT+WIND? command is supported and indicates the <allowed bit flows>. AT+WIND settings are automatically stored in non volatile memory (EEPROM).

29th September 2004

This means the &W command does not need to be used and the selected flows are always activated after boot.

Default value is 0: no flow activated, no indication.

AT+WIND=? gives the possible value range (0-4095)

The unsolicited response will then be:

+WIND : <event> [,<idx>]

<idx>: Call identifier, defined in +CLCC command.

Or for event 10:

+WIND: <event>,<phonebook>,<status>,...,<phonebook>,<status>

Or for event 11:

+WIND: <event>,["<checksum of SM>"],["<checksum of FD>"],["<checksum of ON>"],["<checksum of SN>"],["<checksum of EN>"],["<checksum of LD>"]

Or for event 15 (NITZ indication):

+WIND: <event>[,1,"<Full name>"][,2,"<Short name>"][,3,"<Local time zone>"][,4,"<Universal time and local time zone>"][,5,"<LSA Identity>"][,6,"<Daylight Saving time>"]

29th September 2004

15.2.3 Defined values

<IndLevel>

0	no unsolicited "+WIND: <IndNb>" will occur (default value)
1 (bit 0)	Hardware SIM Insert / Remove indications or SIM presence after software reset
2 (bit 1)	Calling party alert indication
4 (bit 2)	Product is ready to process AT commands (except phonebooks, AOC, SMS), but still in emergency mode.
8 (bit 3)	the product is ready to process all AT commands, at the end of init or after swapping to ADN in case of FDN configuration
16 (bit 4)	a new call identifier has been created (after an ATD command, +CCWA indication)
32 (bit 5)	an active, held or waiting call has been released by network or other party
64 (bit 6)	Network service available indication
128 (bit 7)	Network lost indication
256 (bit 8)	Audio ON indication
512 (bit 9)	SIM Phonebooks reload status
1024 (bit 10)	SIM phonebooks checksum indication
2048 (bit 11)	Interruption indication (only if FTR_INT is activated)
4096 (bit12)	Hardware Rack Open/Closed Indication
8192 (bit13)	NITZ indication

Combination (addition of the values) is used to allow more than one indication flow : $0 \leq \text{IndLevel} \leq 16383$

The response is OK if the values are in the previous range.

29th September 2004

The supported events are:

<event>

Event	Meaning
0	The SIM presence pin has been detected as "SIM removed"
1	The SIM presence pin has been detected as "SIM inserted"
2	Calling party is alerting
3	Product is ready to process AT commands (except phonebooks, AOC, SMS), at init or after AT+CFUN=1
4	Product is ready to process all AT commands, end of phonebook init or swap (FDN to ADN)
5	Call <idx> has been created (after ATD or +CCWA...)
6	Call <idx> has been released, after a NO CARRIER, a +CSSU: 5 indication, or after the release of a call waiting
7	The network service is available for an emergency call.
8	The network is lost.
9	Audio ON.
10	Show reload status of each SIM phonebook after init phase (after Power-ON or SIM insertion).
11	Show the checksum of SIM phonebooks after loading
12	An interruption has occurred
13	The rack has been detected as Closed.
14	The rack has been detected as Opened.
15	The modem received a NITZ information message from the network.

29th September 2004

- for event 10:

<phonebook> : SIM phonebook

"SM"

"FD"

"ON"

"SN"

"EN"

<status> :

0 : Not Reloaded from SIM (no change since last init or SIM removal)

1 : Reloaded from SIM to internal memory (at least one entry has changed)

- for event 11:

<checksum> : 128-bit "fingerprint" of the phonebook.

Note: If the service of the phonebook is not loaded or not present, the checksum is not displayed and two comas without checksum are displayed (,,).

- for event 15:

<Full name> : String, updated long name for current network

<Short name> : String, updated short name for current network

<Local time zone> : Signed integer, The Time Zone indicates the difference, expressed in quarters of an hour, between the local time and GMT.

<Local time zone> : String, Universal Time and Time Zone , in format "yy/MM/dd,hh:mm:ss±zz"
(Year/Month/Day,Hour:Min:Seconds±TimeZone).

The Time Zone indicates the difference, expressed in quarters of an hour, between the local time and GMT.

<LSA Identity> : Hexa String, LSA identity of the current cell in hexa format (3 bytes)

29th September 2004

<**Daylight Saving Time**> : Integer (0-2), When the LTZ is compensated for DST (Day Saving time, or summertime), the serving PLMN shall provide a DST parameter to indicate it. The adjustment for DST can be +1h or +2h.

Note: For NITZ indication, all the fields indicated here are optional. That is why there is an index related to each information:

- 1: Full name for network
- 2: Short name for network
- 3: Local time zone
- 4: Universal time and local time zone
- 5: LSA Identity
- 6: Network Daylight Saving Time

Refer to 3GPP TS 24.008, 3GPP TS 23.040, 3GPP TS 22.042 for more information.

29th September 2004

15.3 Analog digital converters measurements +ADC

15.3.1 Description

This command gets the (DC level * 1024) of ADC A, ADC B, and possibly ADC C. These voltages are coded on 10 bits..

15.3.2 Syntax

Command syntax : AT+ADC=<n>

Response syntax : +ADC: <ADCValA>,<ADCValB>[,<ADCValC>]

Command	Possible responses
AT+ADC=?	+ADC: (0-1)
<i>Note : Ask for the list of possible values</i>	<i>Note : possible values 0 or 1</i>
AT+ADC=0	OK
<i>Note : Select 2 converters (mode 0)</i>	<i>Note : 2 converters mode selected</i>
AT+ADC?	+ADC: 500,412 OK
<i>Note : Ask for the current values of converters in mode 0</i>	<i>Note : Adc A, Adc B on 10 bits</i>
AT+ADC=1	OK
<i>Note : Select 3 converters (mode 1)</i>	<i>Note : 3 converters mode selected</i>
AT+ADC?	+ADC: 712,698,997 OK
<i>Note : Ask for the current values of converters in mode 1</i>	<i>Note: Adc A, Adc B, Adc C on 10 bits</i>

15.3.3 Defined values:

<n>

0 : Select 2 converters

1 : Select 3 converters

29th September 2004

<ADCValA>

ADC A value, coded on 10 bits. The value returned includes the resistor bridge. These values are updated every 10 seconds. Displayed on modes 0 and 1.

<ADCValB>

ADC B value, coded on 10 bits. Displayed on modes 0 and 1.

<ADCValC>

ADC C value, coded on 10 bits. Displayed only on mode 1.

15.4 Mobile Equipment event reporting +CMER

15.4.1 Description

This command enables or disables sending of unsolicited result codes in the case of a key press.

15.4.2 Syntax:

Command Syntax: AT+CMER=<mode>,<keyp>,<disp>,<ind>,<bfr>

Response syntax (key press event report) : +CKEV : <key>,<press>

Response syntax (indicator event report) : +CIEV: <indresp>,<value>.

29th September 2004

Command	Possible responses
AT+CMER=,1 <i>Note : Ask key press event report</i>	OK
	+CKEV:12,1 +CKEV:12,0 <i>Note : Key 12 has been pressed and released.</i>
AT+CMER?	+CMER: 3,1,0,0,0 OK

15.4.3 Defined values

Important note : The parameters <mode>, <disp> and <bfr> are not handled.

<keyp> (keypad) :

0 : No keypad event reporting.

1 : Keypad event reporting are routed using unsolicited code. Only the key pressings not caused by +CKPD are indicated.

2 : Keypad event reporting are routed using unsolicited code. All key pressings are indicated.

Note: As AT software does not manage the emulation of key press, the values 1 and 2 lead to the same results.

<ind>

0 : no indicator event reporting

1 : indicator event reporting using unsolicited result code. Only the indicator events not caused by +CIND shall be indicated by the TA to the TE

2: indicator event reporting using unsolicited result code. All indicator events shall be directed from TA to TE

29th September 2004

<key> : Keyboard map is (5,5)

0	1	2	3	4
5	6	7	8	9
10	11	12	13	14
15	16	17	18	19
20	21	22	23	24

<press>

1: key press

0: key release

<indresp> : indicator order number (as specified for +CIND)

<value> : new value of the indicator

29th September 2004

15.5 Indicator control +CIND

15.5.1 Description

This command is used to read or set the values of ME indicators. If ME does not allow setting of indicators or ME is not currently reachable, an error code is returned.

15.5.2 Syntax

Command Syntax: AT+CIND=[<ind>[,<ind>[,...]]]

Response syntax :

+CIND: <ind>[,<ind>[,...]] *or*

+CIND: (<descr>,(list of supported <ind>s))[,(<descr>,(list of supported <ind>s)) [,...]]

Command	Possible responses
AT+CIND=[<ind>[,<ind>[,...]]]	+CME ERROR: <err> <i>Note : ME not reachable</i>
AT+CIND? <i>Note: read ME indicators current values</i>	+CIND: <ind>[,<ind>[,...]] OK
AT+CIND=? <i>Note: read ME indicators possible values</i>	+CIND: (<descr>,(list of supported <ind>s))[,(<descr>,(list of supported <ind>s)) [,...]] OK
AT+CIND?	+CIND : 1,2,1,1,0,0,0 <i>Note : battchg:1 - max=5, signal:2 - max=5, service:1 - we are registered on the network, message:1 - a SMS has been received, call:0 - no call in progress, roam:0 - not roaming, smsfull:0 - SIM card is not full of SMS</i>
AT+CIND=? <i>Note: read possible value for ME indicators</i>	+CIND: ("battchg",(0-5)),("signal",(0-5)),("service",(0-1)),("message",(0-1)),("call",(0-1)),("roam",(0-1)),("smsfull",(0-1)) OK

29th September 2004

15.5.3 Defined values

<ind> integer type value, which shall be in range of corresponding <descr> :

0: indicator is OFF or in state which can be identified as "OFF" state

1: indicator is ON or in a state that is more substantial than "OFF" state

2: this value is more substantial than 1, and so on.

Note: If the indicator is a simple ON/OFF style element, it has values 0 and 1.

<descr>:

"battchg" : battery charge level (0 – 5)

"signal" : signal quality (0 – 5)

"service" : service availability (0 – 1)

"message" : message received (0 – 1)

"call" : call in progress (0 – 1)

"roam" : roaming indicator (0 – 1)

"smsfull" : SMS memory storage status in the MT (0 – 1)

0 : memory locations are available

1 : memory full

15.6 Mobile equipment control mode +CMEC

15.6.1 Description

This command selects the equipment which operates ME keypad, writes to ME display and sets ME indicators. If operation mode is not allowed by the ME, +CME ERROR: <err> is returned

15.6.2 Syntax

Command Syntax: AT+CMEC=[<keyp>[,<disp>[,<ind>]]]

29th September 2004

Response syntax : +CMEC: <keyp>,<disp>,<ind>

Command	Possible responses
AT+CMEC=[<keyp>[,<disp>[,<ind>]]]	+CME ERROR: <err>
AT+CMEC=[<keyp>[,<disp>[,<ind>]]]	OK
AT+CMEC?	+CMEC: 2,0,0 OK
AT+CMEC=?	+CMEC: (2),(0),(0) OK <i>Note: no change allowed</i>

15.6.3 Defined values:

<keyp>:

0 : ME can be operated only through its keypad (execute command of +CKPD cannot be used)

1 : ME can be operated only from TE (with command +CKPD)

2 : ME can be operated from both ME keypad and TE

<disp>:

0 : only ME can write to its display (command +CDIS can only be used to read the display)

1 : only TE can write to ME display (with command +CDIS)

2 : ME display can be written by both ME and TE

<ind>:

0 : only ME can set the status of its indicators (command +CIND can only be used to read the indicators)

1 : only TE can set the status of ME indicators (with command +CIND)

2 : ME indicators can be set by both ME and TE

29th September 2004

15.7 Read Language Preference +WLPR

15.7.1 Description

Read a Language Preference value of EF-LP. The first indices should have the highest priority.

15.7.2 Syntax

Command syntax: AT+WLPR= <index >

Response syntax: +WLPR: <value>

Command	Possible responses
AT+WLPR? <i>Note : Read command</i>	+WLPR: 4 OK <i>Note : Four language preferences are available in EF-LP</i>
AT+WLPR=1 <i>Note : Read first EF-LP index value</i>	+WLPR: 5 OK <i>Note : Language preference is 5</i>

15.7.3 Defined values:

<index>

offset in the available languages range (SIM dependant).

<value>

Exemple of values for language : (see 23038)

<value>	Language
0	German
1	English
2	Italian
3	French
4	Spanish
5	Dutch
6	Swedish
7	Danish

29th September 2004

8	Portuguese
9	Finnish
10	Norwegian
11	Greek
12	Turkish
13	Hungarian
14	Polish
32	Czech
33	Hebrew
34	Arabic
35	Russian
36	Icelandic

15.8 Write Language Preference +WLPW

15.8.1 Description

Write a Language Preference value in EF-LP

15.8.2 Syntax

Command syntax: AT+WLPW=<index >,<value>

Response syntax: OK or +CME ERROR: <err>

Command	Possible responses
AT+WLPW=1,5 <i>Note : Write Lang Pref equal to 5 in EF-LP with index 1</i>	OK <i>Note : EF-LP correctly updated</i>

15.8.3 Defined values

<index>:

offset in the available languages range (SIM dependant).

<value>

See <value> examples above.

29th September 2004

15.9 Read GPIO value +WIOR

15.9.1 Description

Read the requested GPI or GPIO pin value.

- Note : by default (e.g. after a reset), the I/O ports configuration is set by the +WIOM command.
- This command is allowed only on a Gpio not allocated by an Open-AT embedded application or for bus operations.

15.9.2 Syntax

Command syntax: AT+WIOR=<index>

Response syntax: +WIOR: <value>

Command	Possible responses
AT+WIOR=0 <i>Read I/O (number 0) value</i>	+WIOR: 0 OK <i>GPIO number 0 is reset</i>

15.9.3 Defined values

<index>

Up to ten I/O ports are available. The <index> value is between 0 and 9.

<value>

0: I/O port number <index> is reset.

1: I/O port number <index> is set.

15.10 Write GPIO value +WIOW

15.10.1 Description

Set the requested GPO or GPIO pin value.

Note :

- by default (after a reset), the I/O ports configuration is set by the +WIOM command.
- This command is allowed only on a GPIO not allocated by the Open-AT embedded application or for bus operations.

29th September 2004

15.10.2 Syntax

Command syntax: AT+WIOW=<index >,<value>

Command	Possible responses
AT+WIOW=2,0	OK
<i>Reset I/O (number 2)</i>	<i>GPIO value is written</i>

15.10.3 Defined values

<index>

Up to ten I/O ports are available. The <index> value is between 0 and 9.

<value>

0: I/O port number <index> is reset.

1: I/O port number <index> is set.

29th September 2004

15.11 Input/Output Management +WIOM

15.11.1 Description

This **specific** command allows to set the default GPIOs configuration (input or output) after reset, and each GPIO default value (if set as an output) after reset.

Note :

- This command is allowed only on a GPIO not allocated by the Open-AT embedded application or for bus operations.

15.11.2 Syntax

Command Syntax AT+WIOM=[<GpioDir>],[<GpioVal>]

Command	Possible responses
AT+WIOM?	+WIOM: 1023,0 OK <i>Note: On reset, all GPIOs are set to 0, as an output.</i>
AT+WIOM=?	+WIOM: (0-1023),(0-1023) OK <i>Note: Range allowed for the parameters.</i>
AT+WIOM=254 <i>Note: Set GPIO 0 as an input, and all other GPIOs as outputs (not relevant for Q31x6 product).</i>	OK
AT+WIOM=,128 <i>Note: Set GPIO 8 (on P32X6 product) or GPO 3 (on Q24X6 product) default output value to 1. or GPIO12 (on P51x6 product) or GPIO7 (on Q31x6 product).</i>	OK
AT+WIOM?	+WIOM: 254,128 OK

15.11.3 Defined values

<GpioDir> : Bit table parameter indicating each GPIO direction.

0 : input

1 : output.

Default value :

- 1023 (all GPIOs set as outputs) for Q2xxx and P3xxx modules.

29th September 2004

- 0 (all GPIOs set as inputs) for Q31 and P51 modules.

<GpioVal> : Bit table parameter indicating each output-configured GPIO value (each bit gives the corresponding GPIO default value).

0 : reset (default value)

1 : set

Remark : the GPIOs set as inputs by the <GpioDir> parameter are not affected by the value set by the <GpioVal> parameter.

Notes :

- <GpioDir> bit values for GPI and GPO are ignored.
- <GpioVal> bit values for GPI are ignored.
- GPO0 is used for the SIM level shifter, if any, for Q24x6 and P32x6 products. **If SIM5VONLY or SIM3AND5V features are active, it must not be modified by AT commands.** Its default value depends on SIM feature (see AT+WFM command):

	SIM5VONLY or SIM3AND5V feature
Use of SIM 3V card	default value = 0
Use of SIM 5V card	default value = 1

AT+WIOM is ignored for GPO0.

29th September 2004

- Here is the corresponding table between Module GPIO Pin Names and parameters values (<index>) for AT commands:

Param value for AT Commands	Wismo Quik Q2xx3 Pin Names	Wismo Pac P3xx3 Pin Names	Wismo Quik Q24X6 Pin Names	Wismo Pac P32X6 Pin Names	Wismo Pac P51x6 Pin Names	Wismo Quik Q31x6 Pin Names
0	GPIO 0	GPIO 0	GPIO 0	GPIO 0	GPIO 0	GPI
1	GPO 1	GPI	GPO 1	GPI	GPIO 4	GPO 1
2	GPO 2	GPIO 2	GPO 2	GPIO 2	GPIO 5	GPO 2
3	GPI	GPIO 3	GPI	GPIO 3	GPIO 8	GPIO 3
4	GPIO 4	GPIO 4	GPIO 4	GPIO 4	GPIO 9	GPIO 4
5	GPIO 5	GPIO 5	GPIO 5	GPIO 5	GPIO 10	GPIO 5
6	(no GPIO affected)	(no GPIO affected)	GPO 0	GPO 0	GPIO 11	GPIO 6
7	(no GPIO affected)	(no GPIO affected)	GPO 3	GPIO 8	GPIO 12	GPIO 7
8	(no GPIO affected)	(no GPIO affected)	(no GPIO affected)	(no GPIO affected)	GPO 0	(no GPIO affected)
9	(no GPIO affected)	(no GPIO affected)	(no GPIO affected)	(no GPIO affected)	GPO 1	(no GPIO affected)

15.12 Abort command +WAC

15.12.1 Description

This **specific** command allows SMS, SS and PLMN selection related commands to be aborted.

15.12.2 Syntax

Command syntax: AT+WAC

Command Syntax	Return
AT+WAC	
AT+WAC=?	OK
AT+WAC?	OK

29th September 2004

Example :

Command	Possible responses
AT+COPS=? <i>Note : Available PLMN</i>	
AT+WAC <i>Note : Abort the request of PLMN list</i>	OK <i>Note : PLMN list request aborted</i>

15.12.3 Defined values

No parameter

15.13 Play tone +WTONE

15.13.1 Description

This **specific** command allows a tone to be played on the current speaker or on the buzzer. Frequency, gain and duration can be specified.

15.13.2 Syntax

Command syntax: AT+WTONE=<mode>[,<dest>,<freq>,<gain>,<duration>]

Response syntax: OK or +CME ERROR: <err>

Command	Possible responses
AT+WTONE=1,1,300,9,50 <i>Note : Play a tone</i>	OK <i>Note : Done</i>
AT+WTONE=0 <i>Note : Stop playing</i>	OK <i>Note : Done</i>
AT+WTONE=? <i>Note : Test command</i>	OK <i>Note : Done</i>
AT+WTONE? <i>Note : Current value</i>	ERROR <i>Note :</i>

15.13.3 Defined values

<mode>

0: Stop playing.

1: Play a tone

29th September 2004

<dest>: This parameter sets the destination (mandatory if <mode>=1)

1: Speaker

2: Buzzer

<freq> : This parameter sets tone frequency (in Hz) (mandatory if <mode>=1).

- If **<dest>** = 1 (speaker), range is 300 Hz to 3400 Hz for P51xx modules
range is 1 Hz to 3999 Hz for other modules.
- If **<dest>** = 2 (buzzer), range is 1 Hz to 50000 Hz.

<gain> : This parameter sets the tone gain. The default value is 9.

Range of values is 0 to 15.

<gain>	Speaker (db)	Buzzer (db)
0	0	-0.25
1	-0.5	-0.5
2	-1	-1
3	-1.5	-1.5
4	-2	-2
5	-3	-3
6	-6	-6
7	-9	-9
8	-12	-12
9	-15	-15
10	-18	-18
11	-24	-24
12	-30	-30
13	-36	-40
14	-42	-infinite
15	-infinite	-infinite

<duration>: This parameter sets tone duration (in unit of 100 ms).

Range of values is 0 to 50 (0 is default value, 1 -> 0,1 s., 50 -> 5 s.)

Remark : when **<duration>** = 0, the duration is infinite, and the tone should be stopped by AT+WTONE=0.

29th September 2004

15.14 Play DTMF tone +WDTMF

15.14.1 Description

This **specific** command allows a DTMF tone to be played on the current speaker. DTMF, gain and duration can be specified.

Remark : This command is only used to play a DTMF tone. To send a DTMF over the GSM network, use the +VTS command.

15.14.2 Syntax

Command syntax: AT+WDTMF=<mode>[,<dtmf>,<gain>,<duration>]

Response syntax: OK or +CME ERROR: <err>

Command	Possible responses
AT+WDTMF=1,"*",9,50 <i>Note : Play a DTMF tone</i>	OK <i>Note : Done</i>
AT+WDTMF=0 <i>Note : Stop playing</i>	OK <i>Note : Done</i>
AT+WDTMF=? <i>Note : Test command</i>	+WDTMF: (0-1),(0-9,*,#,A,B,C,D),(0-15),(0-50) OK <i>Note : Done</i>
AT+WDTMF? <i>Note : Current value</i>	ERROR <i>Note :</i>

15.14.3 Defined values

<mode>

0: Stop playing.

1: Play a DTMF tone

<dtmf> : This parameter sets the DTMF to play (mandatory if <mode>=1).

Value must be in {0-9,*,#,A,B,C,D}

<gain>: This parameter sets tone gain. The values are identical to those of the +WTONE (speaker) command. The default value is 9.

Range of values is 0 to 15 (see array on §15.14.3)

29th September 2004

<duration>: This parameter sets the tone duration (in unit of 100 ms).

Range of values is 0 to 50 (0 is default value, 1 -> 0,1 s., 50 -> 5 s.)

Remark : when **<duration>** = 0, the duration is infinite, and the DTMF tone can be stopped by AT+WDTMF=0.

15.15 Wavecom Downloading +WDWL

15.15.1 Description

This **specific** command switches the product to download mode.

Downloading is performed using the 1K-XMODEM protocol.

Important note: Software damages may occur if power is lost or if an hardware reset occurs during the downloading phase. This would seriously affect modem behavior.

15.15.2 Syntax

Command syntax: AT+WDWL

Command	Possible responses
AT+WDWL <i>Note : Switch on downloading mode</i>	+WDWL: 0 <i>Note : Start the downloading</i>
	... <i>Note : Downloading in progress</i>
	AT+CFUN=1 <i>Note : Reset the product at the end</i>
	OK <i>Note : reset completed, new software running</i>
AT+WDWL?	+WDWL: V01.19 OK

15.15.3 Defined values

No parameter

29th September 2004

15.16 Wavecom Voice Rate +WVR

15.16.1 Description

This **specific** command allows the voice rate for bearer voice to be configured for outgoing and ingoing calls.

Note: According to the module capabilities, the following voice coding types are allowed:

- o Module supporting AMR: FR, EFR, AMR-FR, AMR-HR are supported.
- o Module not supporting AMR: FR, EFR, HR are supported.

15.16.2 Syntax

Command syntax :

```
AT+WVR=<out_coding_type>[,<in_coding_type>]
AT+WVR=[<out_coding_type>],<in_coding_type>
AT+WVR?      +WVR: <out_coding_type>,<in_coding_type>
OK
```

Note: <out_coding_type> is related to outgoing calls, and <in_coding_type> to incoming calls.

Command	Possible responses
AT+WVR=1 <i>Note : Configure voice type FR and EFR for outgoing calls only</i>	OK <i>Note : Bearer is configured for outgoing calls</i>
AT+WVR=1,4 <i>Note : Configure voice type FR and EFR for outgoing calls and HR and EFR for incoming calls</i>	OK <i>Note : Bearer is configured for outgoing and incoming calls</i>
AT+WVR=,4 <i>Note : Configure voice type HR and EFR for incoming calls</i>	OK <i>Note : Bearer is unchanged for outgoing calls and configured for incoming calls</i>
AT+WVR=6 <i>Note: Syntax error</i>	+CME ERROR: 3 <i>Note : Syntax error</i>
AT+WVR? <i>Note : Ask for the current values</i>	+WVR: 1,1 OK

Command Syntax	Return
AT+WVR=?	+WVR: (0,2,3),(0,2,3) <i>Note : If Half Rate available</i>
AT+WVR=?	+WVR: (0,1),(0,1) <i>Note : If EFR available</i>
AT+WVR=?	+WVR: (0),(0) <i>Note : If neither HR nor EFR available</i>
AT+WVR=?	+WVR: (0-5),(0-5) <i>Note : If HR and EFR available</i>
AT+WVR=?	+WVR: (0,2,3,10,11,12,13,14),(0,2,3,10,11,12,13,14) <i>Note : If Half Rate and AMR available</i>
AT+WVR=?	+WVR: (0,1,6,9,10,12,13),(0,1,6,9,10,12,13) <i>Note : If EFR and AMR available</i>
AT+WVR=?	+WVR: (0,10,12,13),(0,10,12,13) <i>Note : If AMR available</i>
AT+WVR=?	+WVR: (0-14),(0-14) <i>Note : If HR, EFR and AMR available</i>

1.1.2 Defined values

29th September 2004

<n> : Voice coding type.

Voice coding type	Preferred type	Other supported types	Default values
0	FR		<i>default incoming voice calls rate</i>
1	EFR	FR	
2	HR	FR	
3	FR	HR	
4	HR	EFR	
5	EFR	HR	<i>default outgoing voice calls rate</i>
6	AMR-FR	EFR, AMR-HR	
7	AMR-FR	EFR, AMR-HR, HR	
8	AMR-HR	HR, AMR-FR, EFR	
9	AMR-HR	AMR-FR, EFR	
10	AMR-HR	AMR-FR, FR	
11	AMR-HR	HR, AMR-FR	
12	AMR-FR	AMR-HR	
13	AMR-FR	FR, AMR-HR	
14	AMR-FR	FR, AMR-HR, HR	

15.17 Wavecom Data Rate +WDR

15.17.1 Description

This **specific** command allows the data rate for bearer data to be configured for outgoing and incoming calls.

29th September 2004

15.17.2 Syntax

Command syntax :

```

AT+WDR=<out_coding_type>[,<in_coding_type>]
AT+WDR=[<out_coding_type>],<in_coding_type>
AT+WDR?      +WDR: <out_coding_type>,<in_coding_type>
              OK
    
```

Note: <out_coding_type> is related to outgoing calls, and <in_coding_type> to incoming calls.

Command Syntax	Return
AT+WDR=?	+WDR: (0-2),(0-1) OK <i>Note : If Half Rate available in both directions</i>
AT+WDR=?	+WDR: (0),(1) OK <i>Note : If Half Rate not available.</i>

Command	Possible responses
AT+WDR=1 <i>Note : Configure data type FR, HR with HR preferred, for outgoing calls (<in_coding_type> parameter is ommited)</i>	OK <i>Note : Bearer is configured</i>
AT+WDR=,1 <i>Note : Configure data type FR for incoming calls (<out_coding_type > parameter is ommited)</i>	OK <i>Note : Bearer is configured</i>
AT+WDR=3 <i>Note: Illegal value</i>	+CME ERROR: 3 <i>Note : Syntax error</i>
AT+WDR? <i>Note : Ask for the current value</i>	+WDR: 1,1 OK

29th September 2004

15.17.3 Defined values

<out_coding_type>: Data coding type for outgoing calls.

Data type	coding	Preferred type	Other supported types	Default values
0		FR		
1		HR	FR	
2		FR	HR	<i>default outgoing voice calls rate</i>

<in_coding_type>: Data coding type for incoming calls.

Data type	coding	Type	Default values
0		HR	
1		FR	<i>default incoming data calls rate</i>

15.18 Hardware Version +WHWV

15.18.1 Description

This **specific** command gets the hardware version.

15.18.2 Syntax

Command syntax : AT+WHWV

Command	Possible responses
AT+WHWV <i>Note : Request Hardware Version</i>	Hardware Version 4.14 OK <i>Note : Hardware version is 4.14</i>
AT+WHWV <i>Note : Request Hardware Version</i>	Hardware Version -.— OK <i>Note : No hardware version available</i>

15.18.3 Defined values

No parameter

29th September 2004

15.19 Date of Production +WDOP

15.19.1 Description

This **specific** command gets the date of production. Format of the date is Week/Year (ww/yyyy).

15.19.2 Syntax

Command syntax : AT+WDOP

Command	Possible responses
AT+WDOP <i>Note : Request Date of Production</i>	Production date (W/Y): 01/2000 OK <i>Note : Date of production is WEEK: 01 / YEAR: 2000 (1st week of year 2000)</i>
AT+WDOP <i>Note : Request Date of Production</i>	Production date (W/Y): --/---- OK <i>Note : No date of production available</i>

15.19.3 Defined values

No parameter

15.20 Wavecom Select Voice Gain +WSVG

15.20.1 Description

The product has 2 voice gain controllers, this **specific** command selects the microphone gain controller.

29th September 2004

15.20.2 Syntax

Command syntax : AT+WSVG = <n>

Command	Possible responses
AT+WSVG=<n>	
AT+WSVG=0 <i>Note : Select Controller 1 (Default)</i>	OK <i>Note : Controller 1 selected</i>
AT+WSVG=1 <i>Note : Select Controller 2 (Default)</i>	OK <i>Note : Controller 2 selected</i>
AT+WSVG=? <i>Note : Get the list of possible values</i>	+WSVG: (0-1) <i>Note : possible values 0 or 1</i>
AT+WSVG? <i>Note : Get the current value</i>	+WSVG: 1 <i>Note : Controller 1 is selected</i>

15.20.3 Defined values

<n> Controller

0 : Controller 1 (Default)

1 : Controller 2

29th September 2004

15.21 Wavecom Status Request +WSTR

15.21.1 Description

This **specific** command returns some operation status. It can be used for example to check the state of the initialisation sequence; the different values returned are Not started, Ongoing, Finished.

15.21.2 Syntax

Command syntax: AT+WSTR=<status>

Response syntax: +WSTR: <status>,<value>

Command	Possible responses
AT+WSTR=<status>	+WSTR :<status>,<value>
AT+WSTR=1 <i>Note : Select the status 1 (INIT SEQUENCE)</i>	+WSTR: 1,2 OK <i>Note : Init finished</i>
AT+WSTR=2 <i>Note : Select the status 2 (NETWORK STATUS)</i>	+WSTR: 2,1 OK <i>Note : The network is available</i>
AT+WSTR=? <i>Note : Ask for the list of possible values</i>	+WSTR: (1-2) <i>Note : possible values : 1 and 2</i>

15.21.3 Defined values

<status>

1 : Initialisation sequence

<value>

0 : Not started

1 : On going

2 : Finished

2 : Network status

<value>

0 : No network

1 : Network available

15.22 Wavecom Scan +WSCAN

15.22.1 Description

This **specific** command displays the received signal strength indication (<rssi>) for a specified frequency (in absolute format).

This command is not allowed during communication.

15.22.2 Syntax

Command syntax: AT+WSCAN=<absolute frequency>

Response syntax: +WSCAN: <rssi>

Command	Possible responses
AT+WSCAN=50 <i>Note : Request <rssi> of absolute frequency 50</i>	+WSCAN: 23 OK <i>Note : <rssi> is 23.</i>
AT+WSCAN=1025 <i>Note : Request power of absolute frequency 1025</i>	CME ERROR: 3 <i>Note : 1025 is not a valid absolute frequency</i>

15.22.3 Defined values

<absolute frequency> : frequency in absolute format<rssi>

0 : -113 dBm or less

1 : -111 dBm

2-30 : -109 to -53 dBm

31 : -51dBm or more

99 : not known or not detectable

29th September 2004

15.23 Wavecom Ring Indicator Mode +WRIM

15.23.1 Description

This **specific** command sets the state of the Ring Indicator Mode.

- Up-down RI mode: no pulses are sent before unsolicited AT response. Up-down signals are sent when receiving an incoming call.
- Pulse RI mode: an electrical pulse is sent on the Ring Indicator signal just before sending any unsolicited AT response, in order to lose no AT responses when client tasks are in sleep state. Still in RI mode, when receiving incoming calls, electrical pulses are sent on the RI signal.
- Pulse RI Mode + Pulse On Packet Downloaded: based on Pulse RI mode but an electrical pulse is also sent on the Ring Indicator signal just before sending a downloaded data packet (GPRS or CSD) if the remote client tasks has dropped down his RTS signal.

15.23.2 Syntax

Command syntax: AT+WRIM=<mode>[,<n>]

Command	Possible responses
AT+WRIM=0 <i>Note : Select up-down RI mode</i>	OK <i>Note : up-down RI mode selected</i>
AT+WRIM=1 <i>Note : Select pulse RI mode</i>	OK <i>Note : pulse RI mode selected</i>
AT+WRIM=2,0 <i>Note : Select mode pulse RI + Pulse on downloaded packet, pulse duration is 5 μs</i>	OK <i>Note : mode pulse RI + Pulse on downloaded packet selected</i>
AT+WRIM=? <i>Note : Ask for the list of possible values</i>	+WRIM: (0-2),(0-33) OK <i>Note : possible values 0,1 or 2</i>
AT+WRIM? <i>Note : Ask for the current value</i>	+WRIM: 1,0 OK <i>Note : current RI mode is pulse RI.</i>

29th September 2004

15.23.3 Defined values

<mode>

- 0 Up-down RI mode
- 1 Pulse RI mode
- 2 Pulse RI mode + Pulse on Downloaded Packet

<n>: used only in mode RI Pulse + Pulse on Downloaded packet (<mode>=2).

- 0 Duration of pulse is 5 μ s.
- 1-33 Duration of pulse is n x 30 μ s.

Warning: Pulse duration may be increased by up to 3 ms, due to interrupt processes overhead.

Note: Remind that this mode corresponds to the case where the remote equipment has dropped its RTS signal, to stop its flow control.

15.24 Wavecom 32kHz Power down Mode +W32K

15.24.1 Description

This **specific** command allows the 32kHz power down mode to be enabled or disabled.

Note :

- When power down mode is entered, the product uses a 32kHz internal clock during inactivity stages (despite of its nominal internal clock).
- When enabled, power down mode is active after 1 to 15 minutes. The mode is not stored in EEPROM : the command has to be repeated after a reset.

For additional information on power down mode, see APPENDIX F: Specification of Power Down Control via RS232.

15.24.2 Syntax

Command syntax : AT+W32K=<mode>

Command	Possible responses
AT+W32K=1 <i>Note : Enable 32kHz power down mode</i>	OK <i>Note : 32kHz power down mode is enabled</i>
AT+W32K=0 <i>Note : Disable 32kHz power down mode</i>	OK <i>Note : 32kHz power down mode is disabled</i>

29th September 2004

15.24.3 Defined values

<mode> :

0 : Disable 32kHz power down mode

1 : Enable 32kHz power down mode

15.25 Wavecom Change Default Melody +WCDM**15.25.1 Description**

This **specific** command allows the selection of a manufacturer specific melody.. This default melody will be played for any new incoming voice call, either on the buzzer or on the speaker.

15.25.2 Syntax

Command syntax : AT+WCDM=<melody>,<player>

Command	Possible responses
AT+WCDM=0 <i>Note : Select no melody</i>	OK
AT+WCDM=5 <i>Note : Select melody n°5</i>	OK
AT+WCDM? <i>Note : Indicate the current melody</i>	+WCDM: 5,0 OK <i>Note : Melody n°5 is currently selected, and the buzzer is selected to play it.</i>
	RING <i>Note : An incoming call occurs, and the melody n°5 is played on the buzzer.</i>
AT+WCDM=,1 <i>Note : Select the speaker to play the melody on.</i>	OK
AT+WCDM?	+WCDM: 5,1 OK <i>Note : Now the speaker is selected to play the melody if an incoming call occurs.</i>

15.25.3 Defined values

<melody>

0 : No melody (default)

1 – 10 : Melody 1 to 10

29th September 2004

<player>

0 : Melody n°<melody> will be played on the buzzer for any new incoming voice call. (default)

1 : Melody n°<melody> will be played on the speaker for any new incoming voice call.

15.26 Wavecom Software version +WSSW

15.26.1 Description

This **specific** command displays some internal software reference.

15.26.2 Syntax

Command syntax : AT+WSSW

Command	Possible responses
AT+WSSW	A00_00gm.2c 000000008F5DC6EA
<i>Note : Get Software version</i>	OK
	<i>Note : internal software information</i>

15.26.3 Defined values

No parameter

29th September 2004

15.27 Wavecom Custom Character Set +WCCS

15.27.1 Description

This **specific** command allows to edit and display the custom character set tables. These tables are used by the "CUSTOM" mode of +CSCS and the +WPCS commands. In this CUSTOM mode, when the user enters a string, it is converted into GSM alphabet using the Custom To GSM table. In a similar way, when the user requests a string display, the string is converted from GSM alphabet using the GSM To Custom table.

In edition mode, the session is terminated by <ctrl-Z>, or aborted by <ESC>. Only hexadecimal characters ('0'...'9', 'A'...'F') can be used. The number of characters entered must be equal to the edition range requested, otherwise the command will return "+CME ERROR: 3".

15.27.2 Syntax

Command syntax : AT+WCCS=<mode>,<table>,<char 1>[,<char 2>]

Command	Possible responses
AT+WCCS=0,0,120,130 <i>Note : Display from character 120 to character 130 of the Custom To GSM conversion table</i>	+WCCS: 11, 78797A2020202020097E05 OK <i>Note : 11 characters displayed</i>
AT+WCCS=1,0,115<CR> 20<ctrl-Z> <i>Note : Edit character 115 of the Custom To GSM conversion table</i>	OK <i>Note : Edition successful</i>
AT+WCCS=1,1,0,4<CR> 40A324A5E8<ctrl-Z> <i>Note : Edit the 5 first characters of the GSM To Custom conversion table</i>	OK <i>Note : Edition successful</i>
AT+WCCS=1,1,200 <i>Note : Edit character 200 of GSM To Custom conversion table</i>	+CME ERROR: 3 <i>Note : Index out of range</i>

15.27.3 Defined values

<mode>

0 : Display the table

29th September 2004

1 : Edit the table

<table>

0 : Custom To GSM conversion table

1 : GSM To Custom conversion table

<char 1>, **<char 2>** : Character range to display/edit.

0-127 : for GSM To Custom conversion table

0-255 : for Custom To GSM conversion table

Note : If only **<char 1>** is provided, only this char is displayed/edited.

See section 20.6 for informative examples on phonebooks.

29th September 2004

15.28 Wavecom LoCK +WLCK

15.28.1 Description

This **specific** command allows the ME to be locked on a specific network operator.

Note: Test SIM cards (with MCC=001 & MNC=01) doesn't check these locks.

15.28.2 Syntax

Command syntax: AT+WLCK=<fac>,<passwd>,<NetId>[,<GID1>[,GID2]]
[,<CnIType>[,<CnIData>]]

Response syntax: +WLCK: <status>

Command	Possible responses
AT+WLCK="PN",12345678,20810 <i>Note : Activate network lock on SFR (208,10)</i>	OK <i>Note : Network lock activated</i>
AT+WLCK="PS",12345678,208105923568974 <i>Note : Activate SIM lock</i>	OK <i>Note : SIM lock activated</i>
AT+WLCK="PU",12345678,2081035 <i>Note : Activate Network Subset lock on SFR (208, 10, 35).</i>	OK <i>Note : Network Subset lock activated</i>
AT+WLCK="PU",12345678,20810	+CME ERROR: 3 <i>Note: Need 7 digits of IMSI to perform a service provider lock</i>
AT+WLCK="PP",12345678,20810,"E5" <i>Note : Activate Service Provider lock on SFR (208, 10) and GID1 (0xE5).</i>	OK <i>Note : Service Provider lock activated.</i>
AT+WLCK="PC",12345678,20810,"E5","10" <i>Note : Activate Corporate lock on SFR (208, 10), GID1 (0xE5) and GID2 (0x10).</i>	OK <i>Note : Corporate lock activated.</i>
AT+WLCK="PN",12345678,20810,0 <i>Note : Activate Network lock on SFR (208, 10) using co-operative network list from SIM file EFCNL (must be present in SIM)</i>	OK <i>Note : Network lock activated on SFR and co-operative network list present in SIM</i>

29th September 2004

AT+WLCK="PN",12345678,20801,1,"02F802FFFFFF02F801FFFFFF" <i>Note : Activate Network lock on F ORANGE (208, 01) with manual co-operative network list including SFR (208, 10) and Bouygues Telecom (208, 20)</i>	OK <i>Note : Network lock activated on F ORANGE (primary network), SFR and Bouygues Telecom (co-operative networks)</i>
--	--

15.28.3 Defined values

<fac> :

"PS" : SIM lock facility with a 8 digits password (PCK).

"PN" : Network lock with a 8 digits password (NCK).

"PU" : Network subset lock with a 8 digits password (NSCK).

"PP" : Service provider lock with a 8 digits password (SPCK).

"PC" : Corporate lock with a 8 digits password (CCK).

<CnlType> : Type of lock for cooperative network list (CNL)

0 : Automatic (co-operative network list retrieved from EFCNL SIM file)

Note : EFCNL file must be present in SIM to use automatic mode.

1 : Manual (cooperative network list is given in the <CnlData> parameter)

<CnlData> : Co-operative network list (hexa string type) using same format as in EFCNL SIM file (ETSI GSM 11.11 or 3GPP 04.08).

Note : Only if <CnlType> = 1

15.29 CPHS command: +CPHS

15.29.1 Description

This **specific** command is used to activate, deactivate or interrogate a CPHS feature (e.g. Voice Mail Indicator, Mail Box Number...)

Note : This command may answer +CME ERROR: 3 if the CPHS feature is disabled (cf. +WFM command), or if the SIM card does not support this CPHS feature.

29th September 2004

15.29.2 Syntax

Command syntax : AT+CPHS=<Mode>,<FctId>[,<precision>]

Command	Possible responses
AT+CPHS=<Mode>,<FctId>[,<precision>]	OK
AT+CPHS=<Mode>,<FctId>[,<precision>]	+CME ERROR: 3
AT+CPHS?	+CPHS: <FctId1>,<Status><CR<LF> +CPHS: <FctId2>,<Status><CR<LF> ... +CPHS: <FctIdn>,<Status><CR<LF> OK
AT+CPHS=?	OK

15.29.3 Defined values:

<Mode>

- 0 : Deactivate a CPHS feature
- 1 : Activate a CPHS feature
- 2 : Interrogate a CPHS status

Note : The deactivate or activate command has not effect for Alternate line service, Network Operator Name, CPHS information and Customer Profile Service features.

<FctId>

- 1 : Voice Mail Indicator
- 2 : Mail Box Number
- 3 : Alternate Line Service
- 4 : Diverted Call Indicator
- 5 : Network Operator Name
- 6 : CPHS Information
- 7 : Customer Service Profile

Note : The Customer Service Profile and Alternate Line Service features are activated if the field is set in CPHS information and CSP files. The Network Operator Name is activated if at least one of the two format names exist (Long or Short format). This is done at initialization.

29th September 2004

<precision> :*only used if <Mode>=2 and <Fctld>= 5 to 7*if <Fctld>=5, this field is **<type format>** (See +WNON)if <Fctld>=6, this field is **<data field>** (See +WCPI)if <Fctld>=7, this field is **<service>** (See +WCSP)**<Status>**

0 : CPHS feature disabled

1 : CPHS feature enabled

15.29.4 Examples

AT+CPHS?	<i>Interrogate the status of CPHS functionality</i>
+CPHS: 1,0	<i>The voice mail indicator functionality is deactivated</i>
+CPHS: 2,0	<i>The mail box number functionality is deactivated</i>
+CPHS: 3,1	<i>The Alternate Line Service functionality is activated</i>
+CPHS: 4,0	<i>The Divert Call Indicator functionality is deactivated</i>
+CPHS: 5,1	<i>The Network Operator Name functionality is activated</i>
+CPHS: 6,1	<i>The CPHS Information functionality is activated</i>
+CPHS: 7,1	<i>The Customer Service Profile functionality is activated</i>
OK	
AT+CPHS=3,1	<i>Syntax error</i>
+CME ERROR: 3	
AT+CPHS=1,1	<i>Activate the voice mail indicator functionality</i>
OK	
AT+CPHS?	<i>Interrogate the status of CPHS functionality</i>
+CPHS: 1,1	<i>The voice mail indicator functionality is activated</i>
+CPHS: 2,0	<i>The mail box number functionality is deactivated</i>
+CPHS: 3,1	<i>The Alternate Line Service functionality is activated</i>
+CPHS: 4,0	<i>The Divert Call Indicator functionality is deactivated</i>
+CPHS: 5,1	<i>The Network Operator Name functionality is activated</i>
+CPHS: 6,1	<i>The CPHS Information functionality is activated</i>
+CPHS: 7,1	<i>The Customer Service Profile functionality is activated</i>
OK	

***** the message box contains 1 message *****

29th September 2004

+WVMI: 1,1 *A message is waiting on Line 1*
**** *The message box contains a second message ****
+WVMI: 2,1 *A message is waiting on Line 2*

AT+CPHS=1,4 *Activate the divert call indicator functionality*
OK

**** *the call forwarding is active on Line 1 ******
+WDCI: 1,1 *Call forwarding is activated on Line 1*

AT+CPHS=2,1 *Interrogate the status of voice mail indicator functionality*
+WVMI: 1,1 *a message is waiting on LINE 1*
+WVMI: 2,1 *a message is waiting on LINE 2*
+WVMI: 3,0 *no Data waiting*
+WVMI: 4,0 *no Fax waiting*
OK

AT+CPHS=1,2 *Activate the mail box number functionality*
OK

AT+WALS=1 *Interrogate the status of activated Line*
+WALS: 2 *The current line is number 2*
OK

AT+CPHS=0,4 *Deactivate the divert call indicator functionality*
OK

AT+CPHS? *Interrogate the status of CPHS functionality*
+CPHS: 1,1 *The voice mail indicator functionality is activated*
+CPHS: 2,1 *The mail box number functionality is activated*
+CPHS: 3,1 *The Alternate Line Service functionality is activated*
+CPHS: 4,0 *The Divert Call Indicator functionality is deactivated*
+CPHS: 5,1 *The Network Operator Name functionality is activated*
+CPHS: 6,1 *The CPHS Information functionality is activated*
+CPHS: 7,1 *The Customer Service Profile functionality is activated*
OK

AT+CPHS=2,2 *Query current mail box numbers in SIM*
+WMBN: 1,"19254871234",129,,1 *Mail box number for Line 1*
+WMBN: 2,,,1 *Mail box number for Line 2*
+WMBN: 3,,,1 *Mail box number for Data Line*

29th September 2004

+WMBN: 4,,,1 *Mail box number for Fax Line*
 OK *Only Line1 can be updated*

15.30 Unsolicited result : Wavecom Voice Mail Indicator : +WVMI

15.30.1 Description

This unsolicited indication gives the status of the LINE 1, LINE 2, DATA or FAX mailboxes. The +CPHS command can be used to know the status of voice mail indicator for each line.

15.30.2 Syntax

Response syntax : +WVMI: <LineId>,<Status>

Response syntax (to AT+CPHS=2,1)

+WVMI = <LineId>,<Status>

Command	Possible responses
AT+CPHS=1,1 <i>Note : Activate the Voice Mail indicator feature.</i>	OK
AT+CPHS=2,1 <i>Note : Get the current status of Voice mail indicator.</i>	+WVMI: 1,1 <i>a message is waiting on LINE 1</i> +WVMI: 2,1 <i>a message is waiting on LINE 2</i> +WVMI: 3,0 <i>no Data waiting</i> +WVMI: 4,0 <i>no Fax waiting</i>
AT+CPHS=2,1	+CME ERROR: 3 <i>Note : CPHS Feature is not allowed</i>
AT+CPHS=1,1 <i>Note : Activation of Voice mail indicator feature.</i>	OK <i>Note : The Voice mail indicator feature is activated</i>
	+WVMI: 1,1 <i>Note : A message is waiting on Line 1</i>

15.30.3 Defined values

<LineId>

1 : Line 1

2 : Line 2

29th September 2004

3 : Data

4 : Fax

<Status>

0 : No message waiting.

1 : At least one message is waiting

15.31 Unsolicited result : Wavecom diverted call indicator: +WDCI

15.31.1 Description

This indication provides the call forwarding flags. The +CPHS command can be used to know the status of Divert call indicator for each line.

15.31.2 Syntax

Response syntax: +WDCI:<Lineld>,<flag>

Response syntax (to AT+CPHS=2,4)

+WDCI = <Lineld>,<Status>

Command	Possible responses
AT+CPHS=1,4 <i>Note : Activate the Divert Call indicator feature.</i>	OK
AT+CPHS=2,4 <i>Note : Get the current status of Divert call indicator.</i>	+WDCI: 1,1 <i>divert call indicator is active on LINE 1</i> +WDCI: 2,1 <i>divert call indicator is active on LINE 2</i> +WDCI: 3,0 <i>divert call indicator is deactivate on Data</i> +WDCI: 4,1 <i>divert call indicator is active on Fax</i>
AT+CPHS=2,4	+CME ERROR: 3 <i>Note : CPHS Feature is not allowed</i>
AT+CPHS=1,4 <i>Note : Activation of Divert call indicator feature.</i>	OK <i>Note : The Divert call indicator feature is activated</i>
	+WDCI: 1,1 <i>Note : Call forwarding is activate on Line 1</i>

29th September 2004

15.31.3 Defined values

<Lineld>

1 : Line 1

2 : Line 2

3 : Data

4 : Fax

<flag>, <status>

0 : Call forwarding is deactivated

1 : Call forwarding is activated

*Note : The call forwarding SS is set by the AT+CCFC command.***15.32 Wavecom network operator name: +WNON****15.32.1 Description**

This indication provides the name of the network operator (as a character string). This command is the response to the AT+CPHS 2,5[,<type format>] command.

29th September 2004

15.32.2 SyntaxCommand : AT+CPHS=2,5[,<type format>]Response syntax : +WNON:<type format>,<operator name>

Command	Possible responses
AT+CPHS=2,5 <i>Note : Get the operator name</i>	+WNON: 0,"Orange F" OK
AT+CPHS=2,5,1 <i>Note : Get the short format operator name.</i>	+WNON: 1,"Orange" OK
AT+CPHS=2,5,0	+CME ERROR: 3 <i>Note : When CPHS Feature is not allowed or format name no accessible</i>
AT+CPHS=2,5,1	+CME ERROR: 3 <i>Note : When NON Feature is not allowed or format name no accessible</i>
AT+CPHS=0,5 <i>Note : Deactivation of Network Operator Name feature.</i>	OK <i>Note : No effect.</i>

15.32.3 Defined values

<type format>

0 : Long format operator name

1 : Short format operator name (default value)

<operator name>

The name of the operator, in long or short format

29th September 2004

15.33 Wavecom CPHS information: +WCPI

15.33.1 Description

This indication provide CPHS information; ie. which data field are present in the SIM. This command is the response to the AT+CPHS 2,6[,<data field>] command.

15.33.2 Syntax

Command : AT+CPHS=2,6[,<data field >]

Response syntax : +WCPI: <data field>,<status>

Command	Possible responses
AT+CPHS=2,6 <i>Note : Get the current status for all CPHS info field</i>	+WCPI: 0,"0033000F" OK
AT+CPHS=2,6,13 <i>Note : Get the current status for Call Forward Activated indicator for Line 1.</i>	+WCPI: 13,1 OK <i>Note : Call Forward is active for Line 1.</i>
AT+CPHS=2,6,22 <i>Note : Get the current status for Line 2 Mailbox number.</i>	+WCPI: 22,0 OK <i>Note : Mailbox number for Line2 is not available.</i>
AT+CPHS=2,6,17	+CME ERROR: 3 <i>Wrong data field</i>
AT+CPHS=2,6,22 <i>Note : Get the current status for Line 2 Mailbox number.</i>	+CME ERROR: 3 <i>Note : CPHS Feature is not allowed</i>
AT+CPHS=0,6 <i>Note : Deactivation of CPHS Info feature.</i>	OK <i>Note : No effect.</i>

15.33.3 Defined values

<data field> : value indicating the field of CPHS information (see appendix 19.14)

If <precision> field omitted in the AT+CPHS command, all field of CPHS Info will be displayed.

<status>

0 : data field is set

29th September 2004

1 : data field is unset

When all CPHS information are requested, the status correspond to a bit field (see appendix 19.14)

Note : The field CSP service (<data field> = 1) is used to set or not the CSP feature at the initialisation.

15.34 Wavecom customer service profile: +WCSP

15.34.1 Description

This indication indicates if a service is accessible to the customer. This is the response to the AT+CPHS 2,7,<service > command.

15.34.2 Syntax

Command : AT+CPHS=2,7,<service>

Response syntax: +WCSP: <service>,<status>

Command	Possible responses
AT+WCSP=?	ERROR
AT+WCSP?	ERROR
AT+CPHS=2,7	+CME ERROR: 3 <i>Note : Syntax error</i>
AT+CPHS=2,7,9 <i>Note : Get the current status for Barring of All Outgoing Calls.</i>	+WCSP: 9,1 OK <i>Note : Barring of All Outgoing Calls is customer accessible.</i>
AT+CPHS=2,7,11 <i>Note : Get the current status Barring of Outgoing International Calls</i>	+WCSP: 11,1 OK <i>Note : Barring of Outgoing International Calls is customer accessible.</i>
AT+CPHS=2,7,2 <i>Note : Get the current status Call forwarding on user Busy.</i>	+CME ERROR: 3 <i>Note : CPHS Feature is not allowed</i>
AT+CPHS=0,7 <i>Note : Deactivation of CPHS Info.</i>	OK <i>Note : No effect.</i>

15.34.3 Defined values

<service> value indicating the field of CSP field to display (see appendix 19.15, column External Value)

 confidential ©

Page : 272 / 460

This document is the sole and exclusive property of WAVECOM. Not to be distributed or divulged without prior written agreement. Ce document est la propriété exclusive de WAVECOM. Il ne peut être communiqué ou divulgué à des tiers sans son autorisation préalable.

29th September 2004

<status>

0 : service is not customer-accessible

1 : service is customer-accessible

Note : The field Alternate Line Service (CPHS Teleservices Group) is used to set or not the ALS feature at the initialisation.

15.35 Wavecom Battery Charge Management +WBCM**15.35.1 Description**

This **specific** command allows the management of the battery charging operations (start and stop the charge, enable or disable unsolicited +WBCI Battery Charge Indications). It also sets the battery charge parameters.

29th September 2004

15.35.2 Syntax

Command syntax : AT+WBCM=<Mode>[,<ChargeInd>][,<BattLevelMax>],
 [<BattLevelMin>],[<TPulseInCharge>],
 [<TPulseOutCharge>],[<BattIntRes>]]

Command	Possible responses
AT+WBCM=0 <i>Note : Stop the battery charging.</i>	OK
AT+WBCM=1,1 <i>Start the battery charging with charge indications.</i>	OK
	+WBCI: 2,4060 <i>Note : Unsolicited charge indication: the current battery voltage is 4.06 V. (See +WBCI description)</i>
AT+WBCM=1,0 <i>Note : Start the battery charging without charge indications.</i>	OK
AT+WBCM=2 <i>Note : Get the battery voltage during the charging.</i>	+WBCI: 2,4110 OK <i>Note : See the description of +WBCI unsolicited response. The current battery voltage is 4.11 V.</i>
	+WBCI: 1 <i>Note : The battery voltage has reached the max level. The battery is considered as charged and the charging is stopped.</i>

29th September 2004

Command	Possible responses
AT+WBCM?	+WBCM: 0,0,4200,3300,100,5000,0 OK <i>Note : Current values.</i>
AT+WBCM=0,1 <i>Note : Enable the battery charge unsolicited indications out of charge.</i>	OK
	+WBCI: 3,4195 <i>Note : The current battery voltage is 4.195 V.</i>
AT+WBCM=3,0,3800,3000,500,3000,0 <i>Note : Configure the battery charging parameters.</i>	OK
AT+WBCM=? <i>Note : Get the parameters range.</i>	+WBCM: (0-3),(0-1),(4000-5000),(2800-3800), (100-10000),(100-10000),(0-255) OK
	+WBCI: 0 <i>Note : The battery voltage has reached the min level. The battery is considered as discharged, and the product is turned off, with the +CPOF command behavior.</i>

15.35.3 Defined values

<Mode>

- 0 : Stop the battery charging (default).
- 1 : Start the battery charging.
- 2 : Get the current battery voltage.
- 3 : Set the battery charge parameters.

Note :

When <Mode> = 0 or 1, only the <ChargeInd> parameter can be set. When <Mode> = 2, no additional parameter can be set. When <Mode> = 3, all others parameters can be set.

<ChargeInd>

- 0 : Disable the battery charge unsolicited indications (default value).
- 1 : Enable the battery charge unsolicited indications (see +WBCI description).

29th September 2004

<BattLevelMax> : Maximum level for the battery voltage.

When reached, the battery is considered as charged.

The allowed range is [4000 ; 5000] (in mV, default value is 4200)

<BattLevelMin> : Minimum level for the battery voltage.

When reached, the battery is considered as discharged, and the product is turned off (with the +CPOF command behavior).

The allowed range is [2800 ; 3800] (in mV, default value is 3300)

Note :

The **<BattLevelMax>** and **<BattLevelMin>** parameters cannot be changed during the battery charging (when **<Mode>** = 1).

<TPulseInCharge> Time between pulses for the pulsed charge.

*The pulse duration lasts one second. When the battery charging is started with unsolicited charging indications (**<ChargeInd>** = 1), +WBCI responses are returned by the ME with a period equals to (**<Pulse Time>** (= 1s.) + **<TPulseInCharge>**).*

The allowed range is [100 ; 10000]. (unit is ms, default value is 100).

<TPulseOutCharge> Time between +WBCI unsolicited responses (case **<ChargeInd>** = 1). The allowed range is [100;10000] (in ms, default value is 5000).

<BattIntRes> : Battery Internal Resistor.

This parameter must be set to have correct values with +WBCI unsolicited results.

The allowed range is [0 ; 255] (in mΩ, default value is 0)

Note :

When the **<BattIntRes>** parameter is changed, the product must be reset to take the modification into account.

Remind that **<BattLevelMax>**, **<BattLevelMin>**, **<TPulseInCharge>**, **<TPulseOutCharge>**, **<BattIntRes>** parameters values are saved in EEPROM, and **<ChargeInd>** parameters value is not saved in EEPROM. After a reset, unsolicited battery charge indications are always disabled.

29th September 2004

15.35.4 Module-specific charging features

Auto charging and pre-charging features are implemented on WISMO QUIK series Q31x6 and PAC P51x6.

Pre-charging process:

When the battery level is too low (this voltage is a component-dependant value), the module powers off. As soon as the module is plugged again to a battery charger, it switches automatically to pre-charging mode. This hardware process triggers a limited current charging with respect to the component requirements. When an hardware threshold (of about 3,2 V.) is reached, the pre-charging process ends, and the auto-charging is triggered. This behavior preserves the battery life.

Auto charging mode:

The module switches to auto-charging mode in 2 cases:

- after a pre-charging process
- when both events happen simultaneously:
 - o the battery level is low (less than 3,3 V, that is a non customizable value)
 - o a module reset occurs;

The battery auto charging is similar as a normal battery charging.

15.36 Unsolicited result : Wavecom Battery Charge Indication +WBCI

15.36.1 Description

This unsolicited indication returns information about the battery charge (maximum level reached, current battery voltage).

15.36.2 Syntax

Unsolicited response syntax : +WBCI: <Status>[,<BattLevel>]

15.36.3 Defined values

<Status>

0 : Minimum battery level reached. The battery is considered as discharged.

The product is turned off (as with the +CPOF command).

29th September 2004

1 : Maximum battery level reached. The battery is considered as charged.

The battery charging is stopped.

2 : Battery currently in charge.

3 : Battery currently out of charge.

<BattLevel> : Current battery voltage during or out of the charging.

The possible range is [2800 ; 5000]. (in mV)

Note :

<Status> = 2 and 3 are solicited, by the AT+WBCM=2 command, or unsolicited when the **<ChargeInd>** parameter of the +WBCM command is set to 1. With these **<Status>** values, the **<BattLevel>** parameter is also present.

15.37 Features Management +WFM

15.37.1 Description

This specific command allows some features to be enabled or disabled.

Note :

*After a modification, the changes will be taken into account only after a **reset of the product**.*

15.37.2 Syntax

Command syntax AT+WFM=<mode>[,<FtrID>]

Response syntax +WFM: <FtrID>,<status>,<resetFlag>

Command	Possible responses
AT+WFM=2,"BI9001800"	+WFM: "BI9001800",1,0 OK <i>Note : Dual-band mode 900/1800 is enabled</i>
AT+WFM=1,11 <i>Note : Enable the Mono-band 900 mode</i>	+CME ERROR: 3 <i>Note : Band selection are not allowed with AT+WFM command</i>
AT+WFM=0,61	+CME ERROR: 3 <i>Note : <mode>=0 is not allowed on <FtrID> values with 2 digits</i>
AT+WFM=0,"EFR" <i>Note : Disable the Enhanced Full Rate feature</i>	OK

29th September 2004

Command	Possible responses
AT+WFM=2 <i>Note : Interrogate all <FtrID> status</i>	+WFM: "MONO900",0,0 +WFM: "MONO1800",0,0 +WFM: "MONO1900",0,0 +WFM: "BI9001800",1,0 +WFM: "BI9001900",0,0 +WFM: "MONO850",0,0 +WFM: "BI8501900",0,0 +WFM: "QUADBAND",0,0 +WFM: "EFR",0,1 +WFM: "NOHR_NOECHO",0,0 +WFM: "HR",1,0 +WFM: "ECHO",0,0 +WFM: "HR_ECHO",0,0 +WFM: "DTXDATA",1,0 +WFM: "DATA144",1,0 +WFM: "SIM3VONLY",0,0 +WFM: "SIM5VONLY",0,0 +WFM: "SIM3AND5V",1,0 +WFM: "SIMREMOVE",1,0 +WFM: "NOINTERRUPT",0,0 +WFM: "OFFWHENUNPLUG",0,0 +WFM: "INTERRUPT",1,0 +WFM: "SWITCHATT",1,0 +WFM: "CPHS",1,0 +WFM: "SIMSPEEDENH",0,0 +WFM: "LOCA",0,0 +WFM: "AMR"0,0 OK <i>Note : The modified features have their <resetFlag> parameter set to 1</i>

15.37.3 Defined values

<mode>

0 : disable feature <FtrID>

1 : enable feature <FtrID>

2 : interrogate the status of the <FtrID> feature.

If the <FtrID> parameter is not used, the status of all the features are listed (with several +WFM responses).

29th September 2004

<FtrID>

Numeric value	String value	Meaning
11	"MONO900"	Mono-band mode 900 MHz (def. 0)
12	"MONO1800"	Mono-band mode 1800 MHz (def. 0)
13	"MONO1900"	Mono-band mode 1900 MHz (def. 0)
14	"BI9001800"	Dual-band mode 900/1800 MHz (def. 1)
15	"BI9001900"	Dual-band mode 900/1900 MHz (def. 0)
16	"MONO850"	Mono-band mode 850 MHz (def. 0)
17	"BI8501900"	Dual-band mode 850/1900 MHz (def. 0)
18	"QUADBAND"	Quad-band mode 850/900/1800/1900 MHz
2	"EFR":	Enhanced Full Rate feature (def. 1)
31	"NOHR_NOECHO"	HR and ECHO features are disabled
32	"HR"	Half Rate feature (def. 1 if AMR not available, see note below)
33	"ECHO"	Echo Cancel (def. 0)
34	"HR_ECHO"	HR and ECHO features are enabled
4	"DTXDATA"	Data with DTX feature (def. 1)
5	"DATA144"	Data 14.4 kbit/s feature (def. 1)
61	"SIM3VONLY"	3V SIM voltage mode (def. 0)
62	"SIM5VONLY"	5V SIM voltage mode
63	"SIM3AND5V"	Both 3 and 5V SIM voltage mode (def. 1)
7	"SIMREMOVE"	SIM removal feature (def. 1)
81	"NOINTERRUPT"	No management of interruption (def. 0)
83	"OFFWHENUNPLUG"	Off when unplug mode (def. 0)
84	"INTERRUPT"	interruption for customer (def. 1)
9	"SWITCHATT"	Switch Attenuation feature (def. 1)
A	"CPHS"	CPHS feature (def. 1)
B	"SIMSPEEDENH"	SIM speed enhancement feature (def.0)
C	"LOCA"	Location feature (def. 0)
D	"AMR"	AMR feature (see note below)

Notes :

- *The +WFM response only use alphabetical values for the <FtrID> parameter.*

29th September 2004

- For **<FtrID>** values with two digits (like 1x, 6x or 8x), the **<mode>** 0 value is not allowed. When a « xa » feature is enabled, enabling an other « xb » feature will automatically disable the « xa » feature.

For example, if the "MONO900" feature is enabled, if the "BI9001800" feature is activated, the "MONO900" feature gets automatically disabled.

- The HR and ECHO features have a particular behavior, due to historical reasons. The appropriate way to activate or deactivate this pair of features is to use the corresponding **<FtrId>** :

"HR"	HR only, no ECHO
"ECHO"	ECHO only, no HR
"NOHR_NOECHO"	Neither HR nor ECHO
"HR_ECHO"	Both HR and ECHO

- "MONO900", "MONO850", "MONO1800", "MONO1900", "BI9001900", "BI9001800", "BI8501900" and "QUADBAND" features are read-only. In order to change the Band selection use AT+WMBS command, see § 15.53.
- When the SIMREMOVE feature is activated if the SIM is removed an unsolicited response +WIND: 0 is received and if the SIM is inserted an unsolicited response +WIND: 1 is received.
- When the NOINTERRUPT feature is activated if the pin interrupt is set no action is taken.
- When the OFFWHENUNPLUG feature is activated if the pin interrupt is set an AT+CPOF is executed.
- When the INTERRUPT feature is activated if the pin interrupt is set an unsolicited response +WIND: 12 is received.
- When the SWITCHATT feature is activated the SWITCHATT algorithm is available to the AT+ECHO command.
- If feature SIM5VONLY or SIM3AND5V is used, the user must take care of **not using GPO0** pin : it is reserved for SIM level shifter.
- AMR feature can only be activated for AMR product. If the AMR function is not available, its activation or deactivation has no effect and no ERROR response. WISMO P5186 and Q2426 modules can support AMR feature. If feature is available, default **<mode>** value is 1. It is 0 in the other cases (AMR not supported or not available).
- HR can not be activated when AMR feature is available. If AMR feature is available, default **<mode>** value for HR is 0.

<status>

0 : the **<FtrID>** feature is disabled

1 : the **<FtrID>** feature is enabled

29th September 2004

<resetFlag>

0 : the feature has not been modified since the last boot of the product.

1 : the feature has been modified since the last boot of the product; a reset must be performed to take the modifications into account.

Note : If a feature is reset to its initial value after a modification, the <resetFlag> parameter will be reset to 0.

15.38 Commercial Features Management +WCFM

15.38.1 Description

This command enables ou disables Wavecom specific features. Disabling a feature can be done with no restriction, but a password is required to enable features.

Note : Once a feature successfully enabled or disabled, the product needs to be reset to take the modification into account.

15.38.2 Syntax

Command syntax AT+WCFM=<mode>,[<FtrMask>[,<Password>]]

Command	Possible responses
AT+WCFM=0,"0A00" <i>Note</i> : Disable some features	OK
AT+WCFM=2 <i>Note</i> : Display of the feature status	+WCFM:0000 OK
AT+WCFM=1,"0003","1234567890A BCDEF1234567890ABCDEF12345678 90ABCDEF1234567890ABCDEF" <i>Note</i> : Enable features	OK <i>Note</i> : The features are enabled (the password is correct)
AT+WCFM=1,"0050","1234567890A BCDEF1234567890ABCDEF12345678 90ABCDEF1234567890FFFFFF" <i>Note</i> : Enable features	+CME ERROR: 3 <i>Note</i> : Incorrect password

15.38.3 Defined values

<mode>

0 : disable some features of <FtrMask>

1 : enable some features of <FtrMask>

29th September 2004

2 : display the features state

<FtrMask> : features mask

16 bits hexadecimal string (4 characters from 0 (zero) to 'F')

<PassWord> : Password

256 bits hexadecimal string (64 characters from 0 (zero) to 'F')

15.39 Wavecom Customer storage mirror +WMIR

15.39.1 Description

This **specific** command allows to make a mirror copy of the current configuration parameters in the EEPROM. In case of memory problem for the storage, if a customer mirror already exists, this one will be restored. Otherwise, the Wavecom default mirrored parameters are restored.

15.39.2 Syntax

Command syntax AT+WMIR

Command	Possible responses
AT+WMIR=?	OK
AT+WMIR	OK

Note : Build the Customer Mirror

15.39.3 Defined values

No parameter

29th September 2004

15.40 Wavecom Change Default Player +WCDP

15.40.1 Description

This specific command allows the default melody player to be selected.

15.40.2 Syntax

Command syntax AT+WCDP = <player>

Command	Possible responses
AT+WCDP=?	+WCDP : (0-1) OK
AT+WCDP=0 <i>Note : Select the buzzer.</i>	OK
AT+WCDP?	+WCDP: 0 OK

15.40.3 Defined values

<player>

0 : Buzzer

1 : Speaker

29th September 2004

15.41 Wavecom CPHS Mail Box Number: +WMBN

15.41.1 Description

This specific command sets the different mailbox numbers in SIM. The +CPHS command can be used to know which mailbox numbers can be updated.

15.41.2 Syntax

Command syntax AT+WMBN = <LineId>,<number>,<type>,<name>

Response syntax (to AT+CPHS=2,2)

+WMBN = <LineId>,<number>,<type>,<name>,<status>

Command	Possible responses
AT+WMBN=?	OK
AT+WMBN?	OK
AT+CPHS=2,2 <i>Note : Get the current Mail Box Numbers in SIM</i>	+WMBN: 1,"0123456789",129,"Maison",1 +WMBN: 2,"9876543210",129,"Travail",1 +WMBN: 3,,,1 +WMBN: 4,,,1 OK
AT+WMBN=1,"+33122334455",145 <i>Note : Set mailbox number for line1.</i>	OK <i>Note : Mailbox number for Line1 is set.</i>
AT+WMBN=2 <i>Note : Erase mailbox number & name for line2</i>	OK
AT+CPHS=2,2 <i>Note : Get the current Mail Box Numbers again</i>	+WMBN: 1,"+33122334455",145,,1 +WMBN: 2,,,1 +WMBN: 3,,,1 +WMBN: 4,,,1 OK

15.41.3 Defined values

<LineId>

1 : Line 1

2 : Line 2

3 : Data

4 : Fax

29th September 2004

<number> : Phone number in ASCII format.

<type> : TON/NPI

(Type of address byte in integer format).

<name> : name of mailbox.

Notes :

- *For the <name> parameter all strings starting with "80", "81" or "82" are considered in UCS2 format. See the APPENDIX E: Coding of Alpha fields in the SIM for UCS2. If a wrong UCS2 format is entered, the string is considered as an ASCII string.*
- *The AT command +WPCS affect the format of the Mailbox <name> entry.*

<status>

When checked with "AT+CPHS=2,2", it indicates if the number can be updated or not:

0 : Update is not possible

1 : Update is possible

15.42 Wavecom Alternate Line Service: +WALS

15.42.1 Description

This specific command allows to set and to get the active line. The +CPHS command can be used to know which line is activated.

15.42.2 Syntax

Command syntax AT+WALS = <CmdType>[,<LineId>]

Response syntax (to AT+CPHS=2,3)

+WALS = <LineId>

Command	Possible responses
AT+WALS?	+WALS: 1 OK <i>Note : Display the current active line</i>
AT+WALS=?	+WALS: (0-1),(1-2) OK
AT+WALS = 0,1 <i>Note : Activate Line 1</i>	+WALS: 1 OK
AT+WALS = 0,2 <i>Note : Activate Line 2</i>	+CME ERROR: 3 <i>Note : When the ALS feature is not allowed</i>
AT+WALS = 1 <i>Note : Get the current activate Line</i>	+WALS: 1 <i>Note : Display the current active line</i>
AT+WALS = 1,2	+CME ERROR: 3 <i>Note : Syntax error</i>
AT+CPHS=0,3 <i>Note : Deactivation of ALS feature.</i>	OK <i>Note : No effect.</i>
AT+CPHS=2,3 <i>Note : Interrogate of ALS Feature</i>	+WALS: 1 <i>Note : Display the current active line</i> +CME ERROR: 3 <i>Note : in the case where the ALS feature is not allowed</i>

15.42.3 Defined values

<CmdType>

0 : Set active line

1 : Get active line

<Lineld>:

Only used for <CmdType> = 0

1 : Line 1

2 : Line 2

29th September 2004

15.43 Wavecom Open AT control command +WOPEN

15.43.1 Description

This **specific** command allows to start, stop, delete and get information about the current Open AT embedded application.

Note : *This command is only available if the Open AT feature is enabled (cf +WCFM command).*

15.43.2 Syntax

Command syntax AT+WOPEN=<Mode>

Response syntax +WOPEN: <Mode>[,<IntVersion>[<ExtVersion>]]

Command	Possible responses
AT+WOPEN=?	+WOPEN: (0-4) OK
AT+WOPEN?	+WOPEN: 0 OK
AT+WOPEN=2 <i>Note : Get the Open-AT library versions.</i>	+WOPEN: 2, "AT v2.00", "AT v2.00" OK <i>Note : Open-AT v2.00 library version. An embedded application has been downloaded on this product.</i>
AT+WOPEN=3	OK <i>Note : The objects flash are erased</i>
AT+WOPEN=1 <i>Note : Start the embedded application.</i>	OK +WIND: 3 <i>Note : Product reset in order to start the embedded application.</i>
AT+WOPEN = 3	+CME ERROR: 532 <i>Note : the embedded application is activated so the objects flash are not erased.</i>
AT+WOPEN = 4	+CME ERROR: 532 <i>Note : the embedded application is activated so it cannot be erased</i>
AT+WOPEN=0 <i>Note : Stop the embedded application.</i>	OK +WIND: 3 <i>Note : Product reset in order to stop the embedded application.</i>
AT+WOPEN=3	OK <i>Note : The objects flash are erased</i>

29th September 2004

Command	Possible responses
AT+WOPEN=4	OK <i>Note : the embedded application is erased</i>
AT+WOPEN?	+CME ERROR: 3 <i>Note : The Open AT feature is disabled.</i>

15.43.3 Defined values

<Mode>

0 : Stop the Open-AT embedded application.

If the product was running, it resets.

1 : Start the Open-AT embedded application.

If the product was stopped, it resets.

2 : Get the Open AT library versions.

3 : Erase the objects flash of the Open-AT embedded application.

4 : Erase the Open-AT embedded application.

Note : Mode = 3 and 4 are only available if Open-AT embedded application is stopped (AT+WOPEN=0).

<IntVersion>

Ascii string giving the internal Open AT library version.

<ExtVersion>

Ascii string giving the external Open AT library version.

Note :

If no embedded application is loaded, the <ExtVersion> parameter does not appear.

29th September 2004

15.44 Wavecom Reset +WRST

15.44.1 Description

This **specific** command resets the module after the time specified by the <delay> parameter.

15.44.2 Syntax

Command syntax : AT+WRST =<Mode>,<Delay>

Response syntax : +WRST: <Mode>,<Delay>,<RemainTime>

Command	Possible responses
AT+WRST=?	OK
AT+WRST=0 <i>Note : Disable timer</i>	OK
AT+WRST=1,"001:03" <i>Note : Enable timer and set delay at 1 hour 3 minutes</i>	OK
AT+WRST?	+WRST: 1,"001:03","001:01" OK <i>Note: Timer activated to reset after 1 hour and 3 minutes. At this point, 1 hour and 1 minute remain before next reset.</i>

15.44.3 Defined values

<val1> :

0 : timer reset is disabled

1 : timer reset is enabled

<Delay>: sets the time before reset

Range "000:01"- "168:59" (format hhh:mm)

<RemainTime> : time before next reset

Range "000:01"- "168:59" (format hhh:mm)

29th September 2004

15.45 Set Standard Tone +WSST

15.45.1 Description

This specific command allows to set/get the sound level of the Standard Tones.

15.45.2 Syntax

Command syntax : AT+WSST=[<sound level>][,<ring tone level>]

Command	Possible responses
AT+WSST=0 <i>Note : Set volume to Max.</i>	OK
AT+WSST=15 <i>Note : Set volume to Min.</i>	OK
AT+WSST=,5 <i>Note : Set ring tone level to 5</i>	OK
AT+WSST? <i>Note : get current standard tones sound level</i>	+WSST: 15,5 OK <i>Note : current standard tones level is 15 (mini.), and ring tone level is 5.</i>
AT+WSST=? <i>Note : supported parameters</i>	+WSST: (0-15),(0-15) OK

15.45.3 Defined values

<sound level>

Range [0 ; 15]

0 : Maximum volume (default)

15 : Minimum volume

<ring tone level>

Range [0 ; 15]

0 : Maximum volume (default)

15 : Minimum volume

29th September 2004

15.46 Wavecom Location +WLOC

15.46.1 Description

This specific command can be used by the application to retrieve the following local informations : MCC-MNC, LAC, CI, Network measurement, BCCH channel list, Timing Advance, Date and Time.

Two ways exist for the external application to get these information : on request of the application, or automatically by the module every x seconds (x has to be a multiple of 5 different from 0).

The location feature has to be activated to get information.

if the feature is not activated, "ERROR" is sent.

If the data are not valid at the requested time, the network measurement, BCCH list and Timing Advance cannot be displayed ("," is displayed instead).

15.46.2 Syntax

Command syntax : AT+WLOC =< mode > [, < time period/dump >]

AT+WLOC?

+WLOC: <mode>, <timeperiod>, <dump>

with <mode> :

0 : no automatic mode

1 : automatic mode

<timeperiod>, <dump> :see below.

Command	Possible responses
AT+WLOC=0 <i>Note : stops the display of local information</i>	OK
AT+WLOC=3,255 <i>Note : set the wished information to display (255 -> complete information)</i>	OK
AT+WLOC=1 <i>Note : displays once the local information</i>	+WLOC: 02f802,0006,7772,f13101b04cf51278 91138e95a846d160,8b49d08d0797c419e 272e10889a000009302170399020403c1 020a03c5020a03,00,010121111349ff OK

29th September 2004

Command	Possible responses
AT+WLOC=2,6 <i>Note : 6 is not a multiple of 5</i>	+CME ERROR:3
AT+WLOC=2,10 <i>Note : displays OK then the current local information immediately for the first time and then every 10 seconds.</i>	OK +WLOC: 02f802,0006,7772,ed3001af4cf492780 b040889c74acc23,8b49d08d0797c419e272e1 0889a000009302160399020503c1020a03c5020 a03,00,010121111354ff +WLOC: 02f802,0006,7772,f02d01ae4cf41278 4b03c889c846dba5,8b49d08d0797c419e272e10889a000009302170399020403c1020a03c5020903,00,010121111404ff ...
AT+WLOC=? <i>Note : The feature "loca" is not activated</i>	+CME ERROR:3
AT+WLOC? <i>Note : The feature "loca" is not activated</i>	+CME ERROR:3
AT+WLOC=? <i>Note : The feature "loca" is activated</i>	OK
AT+WLOC?	+WLOC: 0,5,255 OK <i>Note : The location is not in mode automatic, the period value is set to 5 seconds, the configuration value is set to 255</i>
AT+WLOC? <i>Note : The location is in mode automatic, the period value is set to 10 seconds, the configuration value is set to 20</i>	+WLOC: 1,10,20 OK

29th September 2004

15.46.3 Defined values

<mode>

- 0 : Stop automatic shots
- 1 : One shot requested
- 2 : Automatic shots requested (every x seconds)
- 3 : Configuration of the wished information

for <mode> = 2 :

<time period> optional parameter –

Range : [5 – 255] – in seconds

it has to be a multiple of 5.

default value of time period : 5 seconds

The automatic mode for location is saved in EEPROM, so will be taken into account after an Init (+WLOC:... will be displayed).

Fields of the response to AT+WLOC=1 or AT+WLOC=2 :

The format of these fields are as specified in 04.08 :

Parameter	Type
MCC-MNC	3 bytes
LAC	2 bytes
CI	2 bytes
Network measurement	16 bytes
BCCH channel list	Maximum 48 bytes (if version V0 of GSM Rec 11.14-800) Or 129 bytes (if version V1 of GSM Rec 11.14-800). The version number in indicated in TERMINAL PROFILE information in EEPROM. It is not user-customizable. It is configured at production-time.
Timing Advance	1 byte
Date and Time	7 bytes : Date, time and timezone at STLK Format

for mode = 3 :

<dump> optional parameter

Range : [1-255] (at least 1 bit set to 1).

29th September 2004

- if bit 0 set to 1 (value 1) : DaT will be returned in the response
- if bit 1 set to 1 (value 2) : TA will be returned in the response
- if bit 2 set to 1 (value 4) : BCCH will be returned in the response
- if bit 3 set to 1 (value 8) : NetMeas will be returned in the response
- if bit 4 set to 1 (value 16) : CI will be returned in the response
- if bit 5 set to 1 (value 32) : LAC will be returned in the response
- if bit 6 set to 1 (value 64) : MNC-MCC will be returned in the response

Notes :

- After having downloaded the EEPROM configuration: default value of **<dump>** is 0xFF (all information returned).
- The **<dump>** value set with the command "at+wloc=3,xx" is saved in EEPROM, so it will be taken into account after an Init.
- See Appendix C for details on BCCH channel list.

15.47 Wavecom Bus Read +WBR

15.47.1 Description

This **specific** command allows to read a buffer from a specific bus (SPI, I2C Soft or Parallel).

Note : Bus configuration is set by the **+WBM** command.

15.47.2 Syntax

Command syntax : AT+WBR=<BusId>,<Size>[,<Address>[,<Opcode>]]

Response syntax : +WBR: <Data><CR><LF>

OK

Command	Possible responses
AT+WBR=0,9,"ABFF","C9" <i>Note : Read 9 bytes from the SPI bus, after having sent the 0xC9 Opcode byte and ABFF Address.</i>	+WBR: 0A5F98231012345678 OK
AT+WBR=1,5,"2A" <i>Note : Read 5 bytes from the I2C Soft bus, at the 0x2A slave address.</i>	+WBR: 0102030405 OK
AT+WBR=2,2,0 <i>Read 2 bytes from the Parallel bus with the A2 pin set to 0.</i>	+WBR: A000 OK

29th September 2004

15.47.3 Defined values

< BusId >

0 : SPI bus.

1 : I2C Soft bus.

2 : Parallel bus.

<Size>

Size of data to read, in bytes (max 256 bytes).

<Address>

- For SPI bus :
On Q24X3 and P32X3 products :
Up to 2 address bytes as an ASCII hexadecimal string, usable only if the <opcode> byte is set.
If the address field is not used, the parameter must not be set (default).
On Q24X6 and P32X6 products :
Up to 4 address bytes as an ASCII hexadecimal string.
If the <address> field is not used, the parameter must not be set (default).
- For Parallel bus :
0 : set the A2 pin to 0 (default)
1 : set the A2 pin to 1
- For I2C Soft bus :
Slave address byte, in hexadecimal format (default is 0x00).
This is a 7-bits address, shifted to left from 1 bit, padded with the LSB set to 1 (to read), and sent first on the I2C bus before performing the read operation.

<Opcode> (for SPI bus only)

On Q24X3 and P32X3 products :

Up to 1 opcode byte as an ASCII hexadecimal string.

If the <opcode> field is not used, the parameter must not be set (default).

On Q24X6 and P32X6 products :

Up to 4 opcode bytes as an ASCII hexadecimal string.

29th September 2004

If the <opcode> field is not used, the parameter must not be set (default).

15.48 Wavecom Bus Write +WBW

15.48.1 Description

This **specific** command allows to write a buffer on a specific bus (SPI, I2C soft or parallel).

Note : Bus configuration is set by the +WBM command.

15.48.2 Syntax

Command syntax: AT+WBW=<BusId>,<Size>[,<Address>]<CR>
<Data Buffer> <ctrl-Z >

Command	Possible responses
AT+WBW=0,10<CR> 0123456789ABCDEF0123<ctrl-Z> <i>Note : Write 10 bytes on the SPI bus.</i>	OK <i>Note : Data buffer is written on SPI bus.</i>
AT+WBW=1,5<CR> 0246801234<ctrl-Z> <i>Note : Write 5 bytes on the I2C Soft bus.</i>	OK <i>Note : Data buffer is written on I2C Soft bus.</i>
AT+WBW=2,2,0<CR> 434F<ctrl-Z> <i>Note : Write 2 bytes on the Parallel bus with the A2 pin set to 0.</i>	OK <i>Note : Data buffer is written on PARALLEL bus.</i>

15.48.3 Defined values

<BusId>

- 0 : SPI bus.
- 1 : I2C Soft bus.
- 2 : Parallel bus.

<Size>

Size of data buffer, in bytes. (max. 256 bytes)

<Address>

- For SPI bus :

29th September 2004

Not Used

- For Parallel bus :
0 : set the A2 pin to 0 (**default**)
1 : set the A2 pin to 1
- For I2C Soft bus :
Slave address byte, in hexadecimal format (**default "00"**).
This is a 7-bits address, shifted to left from 1 bit, padded with the LSB set to 0 (to write), and sent first on the I2C bus before performing the writing operation.

<Data Buffer> : Data buffer to write on the specific bus.

This parameter must only contain hexadecimal characters (0-9, A-F) **Its length must be twice the <Size> parameter.**

15.49 Wavecom Bus Management +WBM

15.49.1 Description

This **specific** command allows to manage specific buses (SPI, I2C Soft, Parallel) with a given configuration.

15.49.2 Syntax

- Command Syntax for SPI bus

AT+WBM=<BusId>,<Mode>,[<Clock_Speed>],[<Clock_Mode>],
[<ChipSelect>],[<ChipSelectPolarity>],[<LsbFirst>],
[<Gpio ChipSelect>],[<Gpio Handling>]

- Command Syntax for I2C bus

AT+WBM=<BusId>,<Mode>,[<Scl_Gpio>],[<Sda_Gpio>]

- Command Syntax for parallel

The parameters depend on ChipSelect configuration :

if CS is Gpio 5 :

AT+WBM=<BusId>,<Mode>,[<Chip_Select>],[<Order>],[<Gpio_NbWaitS
tate>]

if CS is LCD_EN

AT+WBM=<BusId>,<Mode>,[<Chip_Select>],[<Order>],

29th September 2004

[<LCDEN_AddressSetupTime>],
 [<LCDEN_SignalPulseDuration>],
 [<LCDEN_PolarityControl>]

Command	Possible responses
AT+WBM=0,1,1,3,1,0,1 <i>Open SPI bus with configuration :</i> <i>(on Q24X3 product)</i> <i>Clock Speed : 812 kHz</i> <i>Clock Mode : 3</i> <i>ChipSelect : LCDEN</i> <i>ChipSelectPolarity : LOW</i> <i>LsbFirst : MSB</i>	OK
AT+WBM=1,1,0,4 <i>Open I2C Soft bus with configuration :</i> <i>Scl Gpio : 0</i> <i>Sda Gpio : 4</i>	OK
AT+WBM=2,1,0,1,10, 31,0 <i>Open PARALLEL bus with configuration :</i> <i>(on P32X3 product)</i> <i>ChipSelect : LCDEN</i> <i>Order: Direct</i> <i>LcdenAddressSetUpTime: 10</i> <i>LcdenSignalPulseDuration : 31</i> <i>PolarityControl : low</i>	OK
AT+WBM=0,2	+WBM: 0,1,1,3,1,0,1,0,0 OK
AT+WBM=1,0 <i>Close I2C bus.</i>	OK
AT+WBM=1,2	+WBM: 0,0,0,4 OK
AT+WBM=1,1 <i>Open I2C Soft bus with the last configuration :</i> <i>Scl Gpio : 0</i> <i>Sda Gpio : 4</i>	OK
AT+WBM = 1,2	+WBM: 1,1,0,4 OK

29th September 2004

15.49.3 Defined values

<BusId>

0 : SPI bus.

1 : I2C bus.

2 : Parallel bus. *(Only on Wismo Pac products)*

<Mode>

0 : close bus.

1 : open bus.

2 : get bus status.

15.49.3.1 for SPI bus :

<Clock Speed>

Q24X3 and P32X3 products		Q24X6 and P32X6 products	
Value	Frequency	Value	Frequency
0 (default)	101 kHz	0 (default)	13 MHz
1	812 kHz	1	6.5 MHz
2	1.625 MHz	2	4.33 MHz
3	3.25 MHz	3	3.25 MHz
		4	2.6 MHz
P51xx products		5	2.167 MHz
Value	Frequency	6	1.857 MHz
0 (default)	2.167 MHz	7	1.625 MHz
1	3.23 MHz	8	1.44 MHz
2	4.33 MHz	9	1.3 MHz
3	6.5 MHz	10	1.181 MHz
		11	1.083 MHz
		12	1 MHz
		13	926 kHz
		14	867 kHz
		15	812 kHz

Note for the P51xx products:

To enable the SPI bus on this product, the +WHCNF command should be used to set up SPI clock and data lines, instead of the RI and DCD signals.

wavecom confidential ©

Page : 301 / 460

This document is the sole and exclusive property of WAVECOM. Not to be distributed or divulged without prior written agreement. Ce document est la propriété exclusive de WAVECOM. Il ne peut être communiqué ou divulgué à des tiers sans son autorisation préalable.

29th September 2004

<Clock Mode>

- 0 : rest state is 0, the data is valid on rising edge (**default value**).
- 1 : rest state is 0, the data is valid on falling edge.
- 2 : rest state is 1, the data is valid on rising edge.
- 3 : rest state is 1, the data is valid on falling edge.

<ChipSelect> (default 0)**0 : GPIO (default value)**

Note : See **<GpioChipSelect>** and **<GpioHandling>** parameters.

1 : SPI_EN on Q24X3 and P32X3 products

Note :

on Q24X6 product, the SPI_EN pin is replaced by the GPO 3 output
(Gpio ChipSelect = 7, refer to +WIOM command)

on P32X6 product, the SPI_EN pin is replaced by the GPIO 8 output
(Gpio ChipSelect = 7, refer to +WIOM command)

2 : SPI_AUX on Q24X3 and P32X3 products

Note :

on Q24X6 and P32X6 products, the SPI_AUX pin is replaced by the GPO 0
output (Gpio ChipSelect = 6, please refer to the +WIOM command)

<ChipSelectPolarity>

- 0 : LOW (Chip select signal is valid on low state). (**Default value**).
- 1 : HIGH (Chip select signal is valid on high state)

<LsbFirst>

- 0 : LSB (Data are sent with LSB first)
- 1 : MSB (Data are sent with MSB first) (**default value**)

<Gpio ChipSelect > if ChipSelect = GPIO (default GPIO 0, see § 15.11.3)

The GPIO value is between 0 and 7.

It must be a GPIO or a GPO (**not a GPI**), and not allocated by any Open-AT embedded application.

Please refer to +WIOM command

<Gpio Handling > if ChipSelect = GPIO

- 0 : SPI BYTE (GPIO signal pulse on each written or read byte)
- 1 : SPI FRAME (GPIO signal works as a standard Chip Select signal) (**default value**)

29th September 2004

15.49.3.2 for I2C bus :**<Scl Gpio> (default value is 0)**

The Scl GPIO value is between **0** and **7**.

It must be a GPIO (not a GPI or GPO) and not allocated by an Open-AT embedded application.

<Sda Gpio> (default value is 4)

The Sda GPIO value is between **0** and **7**.

It must be a GPIO (not a GPI or GPO) and not allocated by an Open-AT embedded application.

15.49.3.3 for Parallel bus (only on Pac products) :**<ChipSelect> (default value is 1)**

0 : GPIO 5 (it must not be allocated by any Open-AT application)

1 : LCDEN (same pin as SPI_EN, and Gpio 8 on P32X6 products (it must not be allocated by any Open-AT application))

<Order> (default value is 0)

0 : DIRECT

1 : REVERSE

29th September 2004

<LCDEN AddressSetUpTime> if ChipSelect = LCDEN (default value is 0)

The <Lcd AddressSetUpTime> value is between **0** and **31**.

The resulting time is :

*For P32X3 product : (X * 38.5) ns ;*

*For P32X6 product : (1 + 2 X) * 19 ns.*

This is the time between the setting of an address on the bus, and the activation of the LCD_EN pin (T1 on the figure bellow).

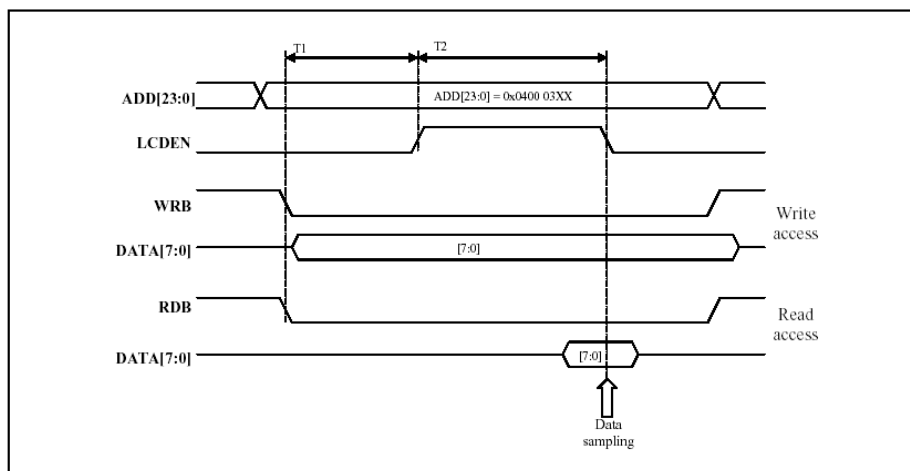

<LCDEN SignalPulseDuration> if ChipSelect = LCDEN (default value is 0)

The <Lcd LcdenSignalPulseDuration> value is between **0** and **31**.

The resulting time is :

*For P32X3 product : (X + 1.5) * 38.5 ns ;*

*For P32X6 product : (1 + 2 * (X + 1)) * 19 ns*

(Warning, for this product, the 0 value in considered as 32).

This is the time during which the LCD_EN signal is valid (T2 on the figure above).

<LCDEN PolarityControl> if ChipSelect = LCDEN (default value is 0)

0 : LOW (LCD_EN signal is valid on low state)

1 : HIGH (LCD_EN signal is valid on high state)

<GPIO NbWaitState> if ChipSelect = GPIO (default value is 0)

This is the time during which the data is valid on the bus.

0 : 62 ns

1 : 100 ns

29th September 2004

2 : 138 ns

3 : 176 ns

Notes :

- If one or two IOs are needed by a bus, they are not available any more for the +WIOR , +WIOW, +WIOM commands. When the corresponding bus is closed, these commands resume the control of the IOs.
- A bus may not be available for an open operation if an Open-AT embedded application has opened it before with the same parameters. In this case, the +WBM command will return +CME ERROR: 3.

15.50 Wavecom Hang-up +WATH

15.50.1 Description

This **specific** command is used by the application to disconnect the remote user, specifying a release cause and the location. In the case of multiple calls, all calls are released (active, on-hold and waiting calls).

15.50.2 Syntax

Command Syntax AT+WATH=<RelCause>,<location>

AT+WATH=31 <i>Note : Ask for disconnection with release cause=normal and location=USER</i>	OK <i>Note : Every call, if any, are released</i>
AT+WATH=?	+WATH: (1-127),(0-5,7,10)
AT+WATH=17,2 <i>Note : Ask for disconnection with release cause=user busy and location= public network serving the local user</i>	OK <i>Note : Every call, if any, are released</i>

15.50.3 Defined values

<RelCause> :

decimal value from 1 to 127 (see the table in appendix 18.4 "Failure Cause from GSM 04.08 recommendation)

<location> :

optional parameter (default value =0)

values as defined in 04.08

29th September 2004

- 0 : user
- 1 : private network serving the local user
- 2 : public network serving the local user
- 3 : transit network
- 4 : public network serving the remote user
- 5 : private network serving the remote user
- 7 : international network
- 10 : network beyond interworking point

Notes:

In order to have a "Normal Release", use ATH command (see paragraph 15.50)

15.51 Write IMEI +WIMEI**15.51.1 Description**

The download of the IMEI is available through this **specific** command. This operation is possible only if the module contains the default IMEI.

The IMEI can only be downloaded once.

No password is needed. If the download is not correct, only Wavecom can reset the IMEI.

15.51.2 Syntax

Command syntax AT+WIMEI=<IMEI>

Command	Possible responses
AT+WIMEI? <i>Request IMEI</i>	+WIMEI: 123456789012345 OK <i>Note: Default IMEI present in EEPROM</i>
AT+WIMEI=123456789099995 First Download	OK
AT+WIMEI=12345 <i>First Download with wrong length of the string</i>	+CME ERROR: 24
AT+WIMEI=123456789999996 <i>Try to overwrite an IMEI already downloaded</i>	+CME ERROR: 3
AT+WIMEI? <i>Request IMEI</i>	+WIMEI: 123456789099995 OK <i>Note: IMEI present in EEPROM</i>
AT+WIMEI=?	OK <i>Note: Command valid</i>

15.51.3 Defined values

<IMEI>

14 or 15 digits as defined by GSM 03.03.

29th September 2004

15.52 Write IMEI SVN: +WSVN

15.52.1 Description

The update of the IMEI SVN is available through this **specific** command.

15.52.2 Syntax

Command syntax : AT+WSVN=<IMEISVN>

Command	Possible responses
AT+WSVN? <i>Note: Request IMEI SVN</i>	+WSVN: 10 OK <i>Note: IMEI SVN present in EEPROM</i>
AT+WSVN=11 <i>Note: Update the IMEI SVN</i>	OK
AT+WSVN=256	+CME ERROR: 24 <i>Note: wrong length of the string. 1 <= IMEI SVN <= 255</i>
AT+WSVN=?	+WSVN: (1-255) OK <i>Note: Command valid</i>

15.52.3 Defined values

<IMEI SVN> IMEI SVN value between 1 and 255

29th September 2004

15.53 Wavecom multi-band selection command: +WMBS

15.53.1 Description

This command permits to select the GSM bands on which the module has to work. This command is allowed only if the selected bands are supported.

The user can choose if the change is immediate or not :

- either the module has to be reset to take this change into account (this is the default case)
- or the GSM stack restarts immediately on the specified band(s). In this mode, the command +WMBS is forbidden during the initialization phase of the modem and during calls.

15.53.2 Syntax

Command syntax : AT+WMBS=<Band>[,<param>]

Response syntax : +WMBS: <Band>,<ResetFlag>

Command	Possible responses
AT+WMBS=<Band>	OK <i>Note: Module has to be reset for change to be effective.</i>
AT+WMBS=<Band>,0	OK <i>Note: Module has to be reset for change to be effective.</i>
AT+WMBS=<Band>,1	OK <i>Note: Band mode selected and GSM stack restarted.</i>
AT+WMBS=<Band>	+CME ERROR: 3 <i>Note: Band not allowed</i>
AT+WMBS?	+WMBS: <Band>,<ResetFlag> OK <i>Note: current selected band mode is returned</i>

29th September 2004

Command	Possible responses
AT+WMBS=?	+WMBS: (0,3,4),(0-1) OK <i>Note: Only 850 mono-band or 850-1900 bi-band are available</i>
AT+WMBS=?	+WMBS: (0,1,2,3,4,5,6),(0-1) OK <i>Note: all bands are available</i>

15.53.3 Defined values

<Band> : frequency band configuration to be supported

- 0 : mono-band mode 850 MHz
- 1 : mono-band mode 900 extended MHz (900E)
- 2 : mono-band mode 1800 MHz
- 3 : mono-band mode 1900 MHz
- 4 : dual-band mode 850/1900 MHz
- 5 : dual-band mode 900E (extended) / 1800 MHz
- 6 : dual-band mode 900E (extended) / 1900 MHz

<Param> : indicates the type of change

- 0 : The module will have to be reset to start on specified band(s). <ResetFlag> is set to 1.
- 1 : The change is effective immediately : the GSM stack is restarted with specified band(s). <ResetFlag> stays at 0. This mode is forbidden while in communication and during modem initialization.

Note: If <Param> is not given, the module has to be reset to start on specified band(s), as for <param>=0.

<ResetFlag>

- 0 : the feature was not modified since the last boot of the product.
- 1 : the feature has been modified since the last boot of the product : it has to be reset in order to take the modification into account. This is the case when the band was changed with "AT+WMBS=<band>" or "AT+WMBS=<band>,0".

29th September 2004

15.54 Module Serial Number +WMSN

15.54.1 Description

This specific command returns the serial number of the module.

15.54.2 Syntax

Command syntax: AT+WMSN

Command	Possible responses
AT+WMSN	Serial Number 12345678901234567 OK <i>Note: Serial number present in Non Volatile Memory is 12345678901234567</i>
AT+WMSN	Serial Number ----- OK <i>Note: No serial number present in Non Volatile Memory</i>

15.54.3 Defined values

No parameters.

15.55 Cellular Text telephone Modem +WCTM

15.55.1 Description

This command allows to activate and deactivate Cellular Text telephone Modem (CTM) capability for outgoing voice call as specified in GSM 04.08 (3GPP 24.008).

CTM mode is used to send audio signals from an external text terminal (ex: a TTY typewriter) within a voice call made by the ME. The text terminal must have a special mobile phone input/output to work correctly.

When the ME indicates support of CTM text telephony for an outgoing voice call, the network shall select a speech CODEC and additionally CTM text telephony detection and conversion functions.

To guaranty optimal audio management of CTM signals, it is mandatory to deactivate Acoustic Echo Cancellation (see Echo Cancellation +ECHO command) and Side Tone (see SideTone modification +SIDET command).

29th September 2004

Voice gain of transmitter and receiver (see Gain control +VGR, +VGT commands) have to be calibrated according to the external text terminal audio characteristics.

15.55.2 Syntax

Command Syntax: AT+WCTM=<mode>

Command	Possible responses
AT+WCTM=1	OK +CME ERROR: <error>
AT+ WCTM?	+WCTM:1 OK
AT+WCTM=?	+WCTM: (0-1) OK

15.55.3 Defined values

<mode>: integer type

- 0 Deactivate CTM mode
- 1 Activate CTM mode

Note : if <mode> is set to 0, all incoming CTM calls will be rejected. Caller will receive a « No carrier » indication.

15.56 Modem Behaviour Configuration +WBHV

15.56.1 Description

This command allows the user to configure the behaviour of Wavecom modem.

If parameter1 = 0, the command is useful to configure the way the modem responds on outgoing voice calls :

The modem response may be sent when the call is established (default mode), or when the audio path is opened.

29th September 2004

If parameter1 = 1, the behavior at init is normal or powerless. In this case, no calls (even emergency calls) are available.

If parameter1 = 2, the module will respond immediately OK after a dial (ATD command).

15.56.2 Syntax

Command syntax : AT+WBHV = <parameter1>,<parameter2>

According to parameter1 :

AT+WBHV = 0,<mode>

AT+WBHV = 1,<mode>

AT+WBHV=2,<mode>

Command	Possible responses
AT+WBHV=0,0 <i>Note : Set modem response to default mode</i>	OK <i>Note : modem response is sent on call establishment</i>
AT+WBHV=0,1 <i>Note : Set modem response when audio path is opened</i>	OK <i>Note : modem response is sent on audio path opened</i>
AT+WBHV=1,0 <i>Note : Modem normal (and default) mode</i>	OK
AT+WBHV=1,1 <i>Note : Modem powerless mode</i>	OK
AT+WBHV?	OK
AT+WBHV=?	+WBHV : 0,(0-1) +WBHV : 1,(0-1) +WBHV : 2,(0-1) OK
AT+WBHV=2,3 <i>Note : Illegal parameters</i>	+CME ERROR:3 <i>Note: Wrong parameters</i>
AT+WBHV=2,1 <i>Note: OK will be displayed just after the ATD command</i>	OK
AT+WBHV=2,0 <i>Note: OK will be displayed when connection is performed.</i>	OK

15.56.3 Defined values

<parameter1> : mode, 0 – 2

0 : configure modem response on outgoing voice calls (default value)

<parameter2> : modem response sending (with parameter1 = 0)

0: modem response sent on call establishment (default value)

1: modem response sent when audio path is opened

1: configure modem mode

<parameter2> : modem init mode (with parameter1 = 1)

0: modem init mode is normal (default value)

1: modem init mode is powerless

2: configure the response delay for a call

<parameter2>: modem response mode on a call

0: response when the remote part hangs up (default value)

1: OK will be displayed immediately after the ATD command

Parameter1 value	Parameter2 value	Meaning
0	0	modem response is sent on call establishment (default)
0	1	modem response is sent when audio path is opened
1	0	Modem normal mode (default)
1	1	Modem powerless mode
2	0	Call response (default)
2	1	Quick call response

29th September 2004

15.57 Hardware Configuration AT+WHCNF

15.57.1 Description

This command permits to change configuration of v24 (V24-RI & v24-DCD) to SPI (SPI-CLOCK & SPI-IO). **This feature is available only on P5186 product.**

Note: At start-up, the module uses the last configuration. There is no need to perform an explicit saving of this parameter. Default configuration is V24.

15.57.2 Syntax

Command syntax : AT+WHCNF = <type>,<mode>[,<param1>]

Command	Possible responses
AT+ WHCNF=0,0 <i>Note : Read info about V24-RI & v24-DCD and SPI-CLOCK & SPI-IO</i>	+WHCNF: 0 OK <i>Note : V24-RI & v24-DCD are available</i>
AT+ WHCNF=0,1,1 <i>Note : Change state to SPI-CLOCK & SPI-IO</i>	OK <i>Note : SPI-CLOCK & SPI-IO are available</i>
AT+ WHCNF?	OK
AT+ WHCNF=?	OK

15.57.3 Defined values

<type>

0 : V24-RI & v24-DCD or SPI-CLOCK & SPI-IO

1 : Reserved for internal use.

2 : Reserved for internal use.

<mode>

For Type = 0

0 : read information about V24-RI & v24-DCD and SPI-CLOCK & SPI-IO

1 : change state between (V24-RI & v24-DCD) and (SPI-CLOCK & SPI-IO)

<param1>

For Type = 0

29th September 2004

0 : V24-RI & v24-DCD active (*default value*)

1 : SPI-CLOCK & SPI-IO active

16 SIM TOOLKIT

16.1 Overview of SIM Application ToolKit

16.1.1 Summary

SIM ToolKit, also known as "SIM Application ToolKit" introduces functionalities, which open the way to a broad range of value added services.

The principle is to allow service providers to develop new applications (*e.g.. for banking, travel, ticket booking, etc.*) for subscribers and to download them into the SIM.

This solution allows new services to be accessible to the user by adding new SIM-based applications without modifying the handset.

16.1.2 Functionality

SIM Toolkit refers to the functionalities described in the GSM Technical specification 11.14.

It introduces twenty five commands for the SIM. Three classes of increasing ToolKit functionalities have been defined, with class 1 offering a subset of commands and class 3 offering the full range of commands (*See table 1 in APPENDIX B*).

The SIM Application Toolkit supports:

- profile download,
- proactive SIM,
- data download into SIM.
- menu selection,
- call control by SIM.

16.1.3 Profile download

The Profile Download instruction is sent by the customer application to the SIM as part of the initialization. It is used to indicate which SIM Application Toolkit features is supported by the customer application.

The AT command used for this operation is **+STSF** (*SIM ToolKit Set Facilities*).

16.1.4 Proactive SIM

A proactive SIM provides a mechanism whereby the SIM can ask the customer application to perform certain actions.

These actions include:

29th September 2004

- display menu,
- display given text,
- get user input,
- send a short message,
- play the requested tone,
- set up a call,
- provide location information.

This mechanism allows SIM applications to generate powerful menu-driven sequences on the customer application and to use services available in the network.

The commands used for this operation are:

- +STIN (*SIM Toolkit Indication*),
- +STGI (*SIM Toolkit Get Information*),
- +STGR (*SIM Toolkit Give Response*).

16.1.5 Data Download to SIM

Data downloading to the SIM (*SMS, phonebook...*) allows data or programs (*Java applets*) received by SMS or by Cell Broadcast to be transferred directly to the SIM Application.

This feature does not need any AT command. It is transparent to the customer application.

16.1.6 Menu Selection

A set of menu items is supplied by the SIM Application ToolKit. The menu selection command can then be used to signal to the SIM Application which menu item is selected.

The commands used for this operation are **+STIN, +STGI and +STGR**.

16.1.7 Call control by SIM

The call control mechanism allows the SIM to check all dialed numbers, supplementary service control strings and USSD strings before connecting to the network. This gives the SIM the ability to allow, bar or modify the string before the operation starts.

The commands used for this operation are :

- +STCR (*SIM Toolkit Control Response*),
- +STGR (*SIM Toolkit Give Response*).

16.2 Messages exchanged during a SIM Toolkit operation.

The following scheme shows the SIM Toolkit commands and unsolicited results that are exchanged.

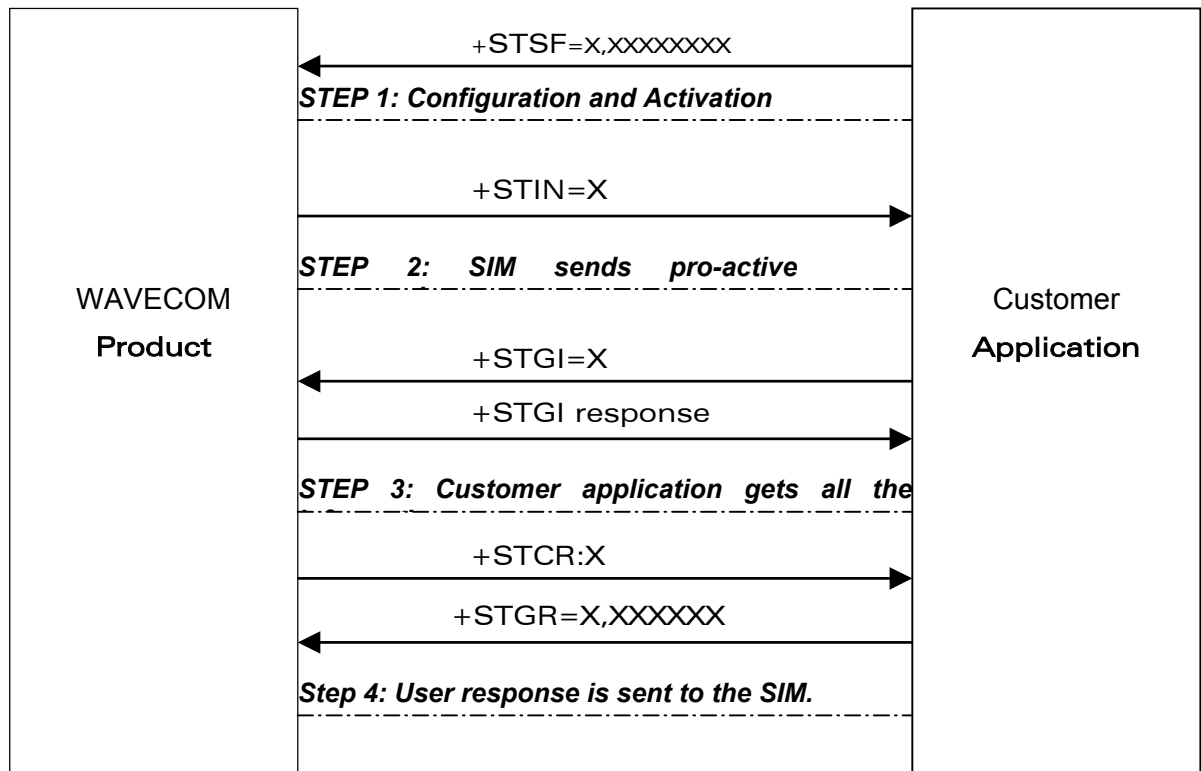

On the first step, the customer application informs the WAVECOM product which facilities are supported. This operation is performed with the **+STSF** (*SIM Toolkit Set Facilities*) command, which also allows to activate or deactivate the SIM Toolkit functionality.

On the second step, an unsolicited result **+STIN** (*SIM Toolkit indication*) is sent by the product, indicating to the customer application which command type the SIM Application Toolkit is running on the SIM card. The last SIM Toolkit indication can be requested by the **+STIN?** command.

On the third step, the customer application uses the **+STGI** (*SIM Toolkit Get Information*) command to get all the information about the SIM Toolkit command, returned by a **+STIN** message.

On the fourth step, the customer application uses the **+STGR** (*SIM Toolkit Give Response*) to send its response (*if any*) to the SIM Toolkit Application.

The **+STCR** (*SIM Toolkit Control response*) indication is an unsolicited result sent by the SIM when Call control functionality is activated and before the customer application has performed any outgoing call, SMS, SS, or USSD.

16.3 SIM TOOLKIT COMMANDS

16.3.1 SIM ToolKit Set Facilities (+STSF)

16.3.1.1 Description

This command allows SIM ToolKit facilities to be activated, deactivated or configured.

16.3.1.2 Syntax

Command syntax :

+STSF=<mode>[,<config>][,<Timeout>][,<AutoResponse>]

Command	Possible responses
+STSF=<Mode>[,<Config>][,<Timeout>][,<AutoResponse>]	OK +CME ERROR: <err>
+STSF?	+STSF: <Mode>,<Config>,<Timeout>,<Autoresponse>
+STSF=?	+STSF: (0-2), (160060C01F - 5FFFFFFF7F),(1-255),(0-1) OK

16.3.1.3 Defined values

<mode>

0 : Deactivates the SIM Toolkit functionalities.

1 : Activates the SIM Toolkit functionalities.

2 : Configures the SIM Toolkit functionalities.

<Config>

(160060C01F - 5FFFFFFF7F) (*hex format*)

<Timeout>

Range 1 to 255 : Timeout for user responses (multiple of 10 seconds).

<Autoresponse>

0 : Automatic response is not activated

wavecom confidential ©

Page : 320 / 460

This document is the sole and exclusive property of WAVECOM. Not to be distributed or divulged without prior written agreement. Ce document est la propriété exclusive de WAVECOM. Il ne peut être communiqué ou divulgué à des tiers sans son autorisation préalable.

29th September 2004

1 : Automatic response is activated

Notes :

- The activation or deactivation of the SIM Toolkit functionalities requires the use of the +CFUN (*Set phone functionality*) command to reset the product. This operation is not necessary if PIN is not entered yet.
- The **<Config>** parameter gives the coding of the TERMINAL PROFILE, precisely the list of SIM Application Toolkit facilities that are supported by the customer application.
- The **<Timeout>** parameter (multiple of 10 seconds) sets the maximum time for the user action (to select an item, to input a text, etc).
- When **<Autoreponse>** is activated, the +STIN indication for Play Tone (5), Refresh (7), Send SS (8), Send SMS (9) or Send USSD (10) is automatically followed by the corresponding +STGI response.

Note:

Some bits are related to the product only and not to the customer application. The product automatically sets these bits to either 0 or 1 whatever the user enters with the +STSF command. Those values are given in Appendix C.

Each facility is coded on 1 bit:

- bit = 1: facility is supported by the customer application.
- bit = 0: facility is not supported by the customer application.

Only the first five bytes of the TERMINAL PROFILE (Class 2) can be configured, the other are set to 0. (*See structure of TERMINAL PROFILE in APPENDIX C*)

16.3.1.4 Error codes

+CME ERROR: 3 **Operation not allowed.** This error is returned when a wrong parameter is entered.

16.3.1.5 Example

AT+CMEE=1 *Enable the reporting of mobile equipment errors*

OK

AT+WIND=15 *Set Wavecom indications*

OK

AT+CPAS *Query ME Status*

29th September 2004

+CPAS: 0 *ME is ready.*
OK

AT+STSF=? *Test command SIM ToolKit Set Facilities*
+STSF: (0-2), (160060C01F - 5FFFFFFF7F),(1-255)
OK

AT+STSF? +STSF: 0,"160060C000",3 *No activation of SIM ToolKit functionality*
OK

AT+STSF=2,"5FFFFFFF7F" *Set all SIM ToolKit facilities (class 3).*
OK

AT+STSF=3 *Syntax Error*
+CME ERROR: 3

AT+STSF=1 *Activation of SIM ToolKit functionality*
OK

AT+CFUN=1 *Reboot Software.*
OK

AT+CPIN? *Is the ME requiring a password?*
+CPIN: SIM PIN *Yes, SIM PIN required*

AT+CPIN=0000
OK *PIN Ok*

AT+STSF? +WIND: 4 *Init phase is complete*
+STSF: 1,"5FFFFFFF7F",3 *SIM ToolKit functionality activated with all facilities*
OK

16.3.2 SIM ToolKit Indication (+STIN +STRIL)

16.3.2.1 Unsolicited result

In order to allow the customer application to identify the pro-active command sent via SIM ToolKit, a mechanism of unsolicited SIM ToolKit indications (**+STIN**) is implemented.

Syntax : +STIN: <CmdType>

<CmdType>

- 0 : a 'Setup Menu' pro-active command has been sent from the SIM.
- 1 : a 'Display Text' pro-active command has been sent from the SIM.
- 2 : a 'Get Inkey' pro-active command has been sent from the SIM.
- 3 : a 'Get Input' pro-active command has been sent from the SIM.
- 4 : a 'Setup Call' pro-active command has been sent from the SIM.
- 5 : a 'Play Tone' pro-active command has been sent from the SIM. (*)

29th September 2004

- 6 : a 'Sel Item' pro-active command has been sent from the SIM.
- 7 : a 'Refresh' pro-active command has been sent from the SIM. (*)
- 8 : a 'Send SS' pro-active command has been sent from the SIM. (*)
- 9 : a 'Send SMS' pro-active command has been sent from the SIM. (*)
- 10 : a 'Send USSD' pro-active command has been sent from the SIM. (*)
- 11 : a 'SETUP EVENT LIST' pro-active command has been sent from the SIM.
- 98 : timeout when no response from user.
- 99 : a "End Session" has been sent from the SIM.

(*) if the automatic response parameter is activated, this indication is followed by the corresponding +STGI response.

In case the customer application needs to exchange SIM Toolkit message directly with the SIM card, the second indication (+STRIL) give the full command string given by the SIM.

Syntax : +STRIL: <CmdTreated>,<Command string>

< CmdTreated >

- 0 : The command must be treated by the application.
- 1 : The command is already treated by the module,

<Command string> string type; Sim command string in hexadecimal format.

29th September 2004

16.3.2.2 Last SIM toolkit indication

The last SIM toolkit indication sent by the SIM can be requested by the **AT+STIN?** command. This command is only usable between the sending of the STIN indication by the SIM (step 2 : see section 16.2) and the response of the user with the +STGI command (step 3).

Command syntax : +STIN?

Command	Possible responses
+STIN? <i>Note : Ask for the last SIM toolkit indication sent by the SIM</i>	+STIN: 0 OK <i>Note : the last SIM toolkit indication was a Setup Menu</i>
+STGI=0	<i>Note : Display the SIM toolkit application menu</i>
+STIN? <i>Note : Ask for the last SIM toolkit indication sent by the SIM</i>	+CME ERROR: 4 <i>Note : operation not supported, the +STGI command has been already used</i>

29th September 2004

16.3.3 SIM ToolKit Get Information (+STGI)

16.3.3.1 Description

This command allows to get the information (*text to display, Menu information, priorities...*) of a pro-active command sent from the SIM.

The information is returned only after receiving a SIM Toolkit indication (+STIN).

16.3.3.2 Syntax

Command syntax : +STGI=<CmdType>

Command	Possible responses
+STGI=<CmdType>	See Table 1 +CME ERROR: <err>
+STGI=?	+STGI: (0-11) OK

Table 1

Cmd Type	Description	Possible responses
0	Get information about 'Setup Menu' pro-active command.	+STGI: <Alpha Identifier menu> +STGI: <Id1>,<NbItems>,<Alpha Id1 Label>,<Help Info>[,<NextActionId>]<CR><LF> +STGI: <Id2>,<NbItems>,<Alpha Id2 Label>,<Help Info>[,<NextActionId>]<CR><LF> [...] No action expected from SIM.
1	Get information about 'Display text' pro-active command.	+STGI: <Prior>,<Text>,<ClearMode> No action expected from SIM.
2	Get information about 'Get Inkey' pro-active command.	+STGI: <Format>,<HelpInfo>[,<TextInfo>] SIM expects key pressed (+STGR).
3	Get information about 'Get Input' pro-active command.	+STGI: <Format>,<EchoMode>,<SizeMin>,<SizeMax>,<HelpInfo>[,<TextInfo>] SIM expects key input (+STGR).
4	Get information about 'Setupt call' pro-active command.	+STGI: <Type>,<CalledNb>,<SubAddress>,<Class> SIM expects user authorization (+STGR).

29th September 2004

Cmd Type	Description	Possible responses
5	Get information about 'Play Tone' pro-active command.	+STGI: <ToneType>[,<TimeUnit>,<TimeInterval>,<TextInfo>] No action.
6	Get information about 'Sel Item' pro-active command.	+STGI: <DefaultItem>, <Alpha Identifier menu><CR><LF> +STGI: <Id1>,<NbItems>,<Alpha Id1 Label>,<Help Info>[,<NextActionId>]<CR><LF> +STGI: <Id2>,<NbItems>,<Alpha Id2 Label>,<Help Info>[,<NextActionId>]<CR><LF> [...]] SIM expects an item choice (+STGR).
7	Get information about 'Refresh' pro-active command.	+STGI: <RefreshType> No action (Refresh done automatically by product).
8	Get information about 'Send SS' pro-active command.	+STGI:<TextInfo> No action (Send SS done automatically by product).
9	Get information about 'Send SMS' pro-active command.	+STGI: <TextInfo> No action (Send SMS done automatically by product).
10	Get information about 'Send USSD' pro-active command.	+STGI: <TextInfo> No action (Send USSD done automatically by product).
11	Get information about 'SETUP EVENT LIST' pro-active command.	+STGI: <Evt>

29th September 2004

16.3.3.3 Defined valuesValues when CmdType=0 (Setup menu)

<Alpha Identifier menu>	Alpha identifier of the main menu.
<Idx> (1-255)	Menu item Identifier.
<NbItems> (1-255)	Number of items in the main menu.
<Alpha Idx Label>	Alpha identifier label of items in ASCII format.
<HelpInfo>	
0:	No help information available.
1:	Help information available.
<NextActionId>	Contains a pro-active command identifier. (see the table in APPENDIX D)

Compared to other commands the customer application can always get information about setup menu after having received the +STIN:0 indication.

Values when CmdType=1 (Display text)

<Prior>	
0:	Normal priority of display.
1:	High priority of display.
<Text>	Text to display in ASCII format.
<ClearMode>	
0:	Clear message after a delay (3
seconds)	
1:	Wait for user to clear message.

Values when CmdType=2 (Get Inkey)

<Format>	
0:	Digit (0-9, *, #, and +)
1:	SMS alphabet default.
2:	UCS2
<HelpInfo>	
0:	No help information available.
1:	Help information available.
<TextInfo>	Text information in ASCII format.

29th September 2004

Values when CmdType=3 (Get Input)**<Format>**

- | | |
|----|--------------------------|
| 0: | Digit (0-9, *, #, and +) |
| 1: | SMS alphabet default. |
| 2: | UCS2 |
| 3: | Unpacked format. |
| 4: | Packed format. |

<EchoMode>

- | | |
|----|-----------|
| 0: | Echo off. |
| 1: | Echo on. |

<SizeMin> (1-255) Minimum length of input.**<SizeMax> (1-255)** Maximum length of input.**<HelpInfo>**

- | | |
|----|--------------------------------|
| 0: | No help information available. |
| 1: | Help information available. |

<TextInfo> Text information in ASCII format.Values when CmdType=4 (Setup Call)**<Type>**

- | | |
|----|---|
| 0: | Set up call but only if not currently busy on another call. |
| 1: | Set up call, putting all other calls (<i>if any</i>) on hold. |
| 2: | Set up call, disconnecting all other calls (<i>if any</i>). |

<CalledNb> Called party number in ASCII format.**<SubAdress>** Called party sub-address in ASCII format.**<Class>**

- | | |
|----|-------------|
| 0: | Voice call. |
| 1: | Data call. |
| 2: | Fax call |

29th September 2004

Values when CmdType=5 (Play tone)**<ToneType>**

0:	Tone Dial.
1:	Tone Busy.
2:	Tone Congestion.
3:	Tone Radio ack
4:	Tone Dropped.
5:	Tone Error.
6:	Tone Call waiting.
7:	Tone Ringing.
8:	Tone General beep.
9:	Tone Positive beep.
10:	Tone Negative beep.

<TimeUnit>

0:	Time unit used is minutes.
1:	Time unit used is seconds.
2:	Time unit used is tenths of seconds.

<TimeInterval> (1-255) Time required expressed in units.**<TextInfo>** Text information in ASCII format.Values when CmdType=6 (Sel Item)**<DefaultItem> (1-255)** Default Item Identifier.**<Alpha Identifier menu>** Alpha identifier of the main menu.**<Idx> (1-255)** Identifier items.**<NbItems> (1-255)** Number of items in the menu.**<Alpha Idx Label>** Alpha identifier label of items in ASCII format.**<HelpInfo>**

0:	No help information available.
1:	Help information available.

<NextActionId> Contains a pro-active command identifier.
(see the table in APPENDIX D)

29th September 2004

Values when CmdType=7 (Refresh)**<RefreshType>**

- | | |
|-----------|---|
| 0: | SIM initialization and full file change notification. |
| 1 | File change notification. |
| 2 | SIM initialization and file change notification. |
| 3 | SIM initialization. |
| 4 | SIM reset. |

Values when CmdType=8 (Send SS)**<TextInfo>** Text information in ASCII format.Values when CmdType=9 (Send SMS)**<TextInfo>** Text information in ASCII format.Values when CmdType=10 (Send USSD)**<TextInfo>** Text information in ASCII format.Values when CmdType=11 (Setup Event List)**<Evt>**

- | | |
|-----------|---|
| 1: | Reporting asked for an 'Idle Screen' event. |
| 2: | Reporting asked for an 'User Activity' event. |
| 3: | Reporting asked for 'Idle Screen' and 'User Activity' events. |
| 4: | Cancellation of reporting event. |

Rem : For the UCS2 format texts are displayed in Hexa Ascii format. Example : When the SIM sends a TextString containing 0x00 0x41 the text displayed is "0041".

16.3.3.4 Error codes

+ CME ERROR: 3 **Operation not allowed.** This error is returned when a wrong parameter is detected.

29th September 2004

+CME ERROR: 4 **Operation not supported.** This error is returned when the user wants to get information about a SIM ToolKit proactive command (with SIM ToolKit functionality not activated.)

+CME ERROR: 518 **SIM ToolKit indication not received.** This error is returned when the SIM Toolkit indication (**+STIN**) has not been received.

16.3.3.5 Example

Initially, all facilities are activated, the PIN is not required and SIM toolkit functionality is activated.

```
AT+CMEE=1                    Enable the reporting of mobile equipment errors
OK
AT+WIND=15                    Set Wavecom indications
OK
AT+STSF?
+STSF: 1,"5FFFFFFF7F",3     SIM ToolKit functionality activated with all facilities.
OK
+STIN: 0                      The main menu has been sent from the SIM.
AT+STIN?
+STIN: 0
OK
AT+STGI=0                    Get information about the main menu
+STGI: "SIM TOOLKIT MAIN MENU" Main menu contains 3 items.
+STGI: 1,3,"BANK",0
+STGI: 2,3,"QUIZ",0
+STGI: 3,3,"WEATHER",0
OK
AT+STIN?
+CME ERROR: 4
```

16.3.4 Unsolicited Result : SIM ToolKit Control Response (+STCR)

When the customer application makes an outgoing call or an outgoing SMS and if the call control facility is activated, CALL CONTROL and SMS CONTROL responses can be identified. This is also applicable to SS calls.

Syntax : +STCR: <Result>[,<Number>,<MODestAddr>,<TextInfo>]

Option :

<Result>

0: Control response not allowed.

1: Control response with modification.

29th September 2004

<Number>	Called number, Service Center Address or SS String in ASCII format.
<MODestAddr>	MO destination address in ASCII format.
<TextInfo>	Text information in ASCII format.

16.3.5 SIM ToolKit Give Response (+STGR)

16.3.5.1 Description

This command allows the application/user to select an item in the main menu, or to answer the following proactive commands :

- GET INKEY Key pressed by the user.
- GET INPUT Message entered by the user.
- SELECT ITEM Selected item.
- SETUP CALL User confirmation.
- DISPLAY TEXT User confirmation to clear the message.
- SETUP EVENT LIST Reporting events.

It is also possible to terminate the current proactive command session by sending a Terminal Response to the SIM, with the following parameters :

- BACKWARD MOVE Process a backward move
- BEYOND CAPABILITIES Command beyond ME capabilities
- UNABLE TO PROCESS ME is currently unable to process command
- NO RESPONSE No response from the user
- END SESSION User abort.

29th September 2004

16.3.5.2 Syntax

Command syntax : +STGR=<CmdType>[,<Result>,<Data>]

Command	Possible responses
+STGR=<CmdType>[,<Result>,<Data>]	OK +CME ERROR: <err>
For GetInput with <Result>=1: +STGR=3,1<CR> <Data><Ctrl Z>	OK +CME ERROR: <err>
For GetInkey with <Result>=1 +STGR=2,1,"<Data>"	OK +CME ERROR: <err>
+STGR=?	OK

16.3.5.3 Defined values

<CmdType>

- 0: Item selection in the main menu.
- 1: User confirmation to clear a 'Disp Text'.
- 2: Response for a 'Get Inkey'.
- 3: Response for a 'Get Input'.
- 4: Response for a 'Setup call'.
- 6: Response for a 'Sel Item'.
- 11 Reponse for a 'Setup event list'.
- 95 Backward move
- 96 Command beyond ME capabilities
- 97 ME currently unable to process command
- 98 No response from the user.
- 99 User abort.

Values when CmdType=0 (Select an item from the main menu)

<Result>

- 1: Item selected by the user.
- 2: Help information required by user.

<Data> Contains the item identifier of the item selected by the user.

29th September 2004

Values when CmdType=1 (Confirm the display text clearing)

No values.

Values when CmdType=2 (Get Inkey)**<Result>**

- 0:** Session ended by user.
- 1:** Response given by the user.
- 2:** Help information required by user.

<Data> Contains the key pressed by the user.Values when CmdType=3 (Get Input)**<Result>**

- 0:** Session ended by user.
- 1:** Response given by the user.
- 2:** Help information required by user.

<Data> Contains the string of characters entered by the user.

Note:

For Inputs in UCS2 format, the data are entered in ASCII format. Example : For "8000410042FFFF" entered, the SIM receives 0x00 0x41 0x00 0x42 with UCS2 DCS. (See the Appendix E about the different UCS2 syntaxes).

Values when CmdType=4 (Setup call)**<Result>**

- 0:** User refuses the call.
- 1:** User accepts call.

Values when CmdType=6 (Select Item)**<Result>**

- 0:** Session terminated by the user
- 1:** Item selected by the user
- 2:** Help information required by the user
- 3:** Return to the back item

<Data> Contains the item identifier selected by the user

29th September 2004

Values when CmdType=11 (Setup Event List)

<Result>

- 1: Idle screen available.
- 2: User activity event.

Sending a Terminal Response to the SIM :Values when CmdType=95 (**Backward Move**)Values when CmdType=96 (**Command beyond ME capabilities**)Values when CmdType=97 (**ME currently unable to process command**)Values when CmdType=98 (**No response from the user**)Values when CmdType=99 (**SIM Toolkit Session aborting by the user**)**No values.**

It is possible to send a Terminal Response after the **+STIN** indication (step 2, cf §16.2), or after the **+STGI** command (step 3).

Note :

*For the SETUP MENU Proactive Command, it is only possible to send a Terminal Response after the **+STIN: 0** indication, not after a **+STGI=0** request.*

*All of the Terminal Responses are not possible with all of the Proactive Commands. Compatibility between available Terminal Responses and Proactive Commands is given in Appendix B, Table 2. If a Terminal Response is attempted during a incompatible Proactive Command session, a **+CME ERROR: 3** will be returned.*

16.3.5.4 Possible error codes

- + CME ERROR: 3** **Operation not allowed.** This error is returned when a wrong parameter is detected.
- +CME ERROR: 4** **Operation not supported.** This error is returned when the user gives a response with SIM ToolKit functionality not activated. Or if the SIM Toolkit indication (**+STIN**) has not been received.

29th September 2004

16.3.5.5 Example

Initially, all facilities are activated, the PIN is not required and the SIM toolkit functionality is activated.

```

+STIN: 0                The main menu has been sent from the SIM.
AT+STGI=0              Get information about the main menu
+STGI: 1,3,"BANK",0    The main menu contains 3 items.
+STGI: 2,3,"QUIZ",0
+STGI: 3,3,"WEATHER",0
OK
AT+STGR=0,1,1         The item 2 of the main menu has been selected.
OK
+STIN: 6              The Sel item menu has been sent from the SIM.
AT+STGI=6             Get information about the BANK menu
+STGI: 1,"BANK"       The BANK menu contains two items.
+STGI: 1,2,"PERSONAL ACCOUNT ENQUIRY",1
+STGI: 2,2,"NEWS",0
OK
AT+STGR=6,1,1        Select Item 1.
OK
+STIN: 3              User request to enter Password sent.
AT+STGI=3            Get information about this request.
+STGI: 0,0,4,4,0,"Enter Account Password:"
OK
AT+STGR=3,1<CR>      The user enters the Password.
>0000<Ctrl Z>
OK
+STIN:1              A text info has been sent from the SIM.
AT+STGI=1            Get information about this text.
+STGI: 0,"Password correct, please wait for response",0
OK
+STIN: 9              SIM requests a bank account update from bank server via the
                    network (SEND SMS)
AT+STGI=9            Get all information about the SEND SMS
+STGI: "Send account balance of user, authorization ok"
OK
    
```

***** After a short period of time. *****

```

+STIN: 5              Transaction is complete: BEEP
+STGI=5              Get information about the Tone
+STGI: 9,1,1
+STIN: 1              Display text indication
AT+STGI=1
    
```

29th September 2004

+STGI: 0,"Your account balance is 1000 \$",0

OK

17 GPRS commands

GPRS commands are not available under GSM-only software.

17.1 Define PDP Context +CGDCONT

17.1.1 Description

This command specifies PDP context parameter values for a PDP context identified by the local context identification parameter, <cid>.

Four PDP contexts can be defined through Wavecom software.

A special form of the set command, +CGDCONT= <cid> causes the values for context number <cid> to become undefined.

The test command returns values supported as a compound value. If the MT supports several PDP types, <PDP_type>, the parameter value ranges for each <PDP_type> are returned on a separate line.

The read command returns the current settings for each defined context.

The test command returns values supported as a compound value. If the MT supports several PDP types, <PDP_type>, the parameter value ranges for each <PDP_type> are returned on a separate line.

17.1.2 Syntax

Command	Possible response(s)
---------	----------------------

29th September 2004

Command	Possible response(s)
AT+CGDCONT=[<cid> [,<PDP_type> [,<APN> [,<PDP_addr> [,<d_comp> [,<h_comp>]]]]]]	OK ERROR
AT+CGDCONT?	+CGDCONT: <cid>, <PDP_type>, <APN>, <PDP_addr>, <data_comp>, <head_comp> [<CR><LF>+CGDCONT: <cid>, <PDP_type>, <APN>, <PDP_addr>, <data_comp>, <head_comp> [...]] OK
AT+CGDCONT=?	+CGDCONT: (range of supported <cid>s), <PDP_type>,...(list of supported <d_comp>s), (list of supported <h_comp>s) [<CR><LF>+CGDCONT: (range of supported <cid>s), <PDP_type>,...(list of supported <d_comp>s),(list of supported <h_comp>s) [...]] OK
AT+CGDCONT: 1, "IP", "internet"; +CGDCONT=2, "IP", "abc.com"	OK
AT+CGDCONT=?	+CGDCONT : (1-4),"IP" ,,,(0-1),(0-1) +CGDCONT : (1-4),"PPP" ,,,0,0 OK
AT+CGDCONT?	+CGDCONT: 1, "IP", "internet" ,,0,0 +CGDCONT: 2, "IP", "abc.com" ,,0,0 OK

17.1.3 Defined values

<cid>: (PDP Context Identifier) a numeric parameter which specifies a particular PDP context definition. The parameter is local to the TE-MT interface and is used in other PDP context-related commands. Range of values is 1 to 4.

<PDP_type>: (Packet Data Protocol type) a string parameter which specifies the type of packet data protocol

- IP: Internet Protocol
- PPP : Point to Point Protocol

<APN>: (Access Point Name) a string parameter, which is a logical name that is used to select the GGSN or the external packet data network.

If the value is null or omitted, then the subscription value will be requested.

29th September 2004

<PDP_address>: a string parameter that identifies the MT in the address space applicable to the PDP.

If the value is null or omitted, then a value may be provided by the TE during the PDP startup procedure or, a dynamic address will be requested. The read form of the command will return the null string even if an address has been allocated during the PDP startup procedure. The allocated address may be read using the **+CGPADDR** command.

<d_comp>: a numeric parameter that controls PDP data compression

- 0 : OFF (default if value is omitted)
- 1 : ON
- Other values are reserved.

<h_comp>: a numeric parameter that controls PDP header compression

- 0 : OFF (default if value is omitted)
- 1 : ON
- Other values are reserved.

Notes :

- The data compression algorithm provided in SMDCP is V.42bis.
- 4 cids are available to specify 4 PDP contexts but only 11 NSAPI are available for PDP activation. Due to Wavecom Choice, 4 PDP contexts can be specified with only one activated at the same time.

17.2 Quality of Service Profile (Requested) +CGQREQ

17.2.1 Description

This command allows the TE to specify a Quality of Service Profile that is used when the MT sends an Activate PDP Context Request message to the network.

The set command specifies a profile for the context identified by the local context identification parameter, <cid>. Since this is the same parameter that is used in the **+CGDCONT** command, the **+CGQREQ** command is effectively an extension to the **+CGDCONT** command. The QoS profile consists of a number of parameters, each of which may be set to a separate value.

29th September 2004

A special form of the set command, +CGQREQ= <cid> causes the requested profile for context number <cid> to become undefined.

The read command returns the current settings for each defined context.

The test command returns values supported as a compound value. If the MT supports several PDP types, the parameter value ranges for each PDP type are returned on a separate line.

17.2.2 Syntax

Command	Possible Response(s)
AT+CGQREQ=[<cid> [,<precedence > [,<delay> [,<reliability.> [,<peak> [,<mean>]]]]]]	OK ERROR
AT+CGQREQ?	+CGQREQ: <cid>, <precedence >, <delay>, <reliability>, <peak>, <mean> [<CR><LF>+CGQREQ: <cid>, <precedence >, <delay>, <reliability.>, <peak>, <mean> [...]] OK
AT+CGQREQ=?	+CGQREQ: <PDP type>, (list of supported <precedence>s), (list of supported <delay>s), (list of supported <reliability>s) , (list of supported <peak>s), (list of supported <mean>s) [<CR><LF>+CGQREQ: <PDP type>, (list of supported <precedence>s), (list of supported <delay>s), (list of supported <reliability>s) , (list of supported <peak>s), (list of supported <mean>s) [...]] OK
AT +CGQREQ=1,1,4,5,2,14	OK
AT+CGQREQ=?	+CGQREQ:"IP", (1-3), (1-4), (1-5), (1-9), (1-31) +CGQREQ:"PPP", (1-3), (1-4), (1-5), (1-9), (1-31) OK
AT+CGQREQ?	+CGQREQ: 1,1,4,5,2,14 OK

17.2.3 Defined values

29th September 2004

<cid>: numeric parameter which specifies a particular PDP context definition.

Range of values is 1 to 3

<precedence>: numeric parameter which specifies the precedence class

0 : Subscribed precedence (Subscribed by the Network by default if value is omitted)

1 : High priority (Service commitments shall be maintained ahead of precedence classes 2 and 3)

2 : Normal priority (Service commitments shall be maintained ahead of precedence class 3.)

3 : Low priority (Service commitments shall be maintained after precedence classes 1 and 2)

<delay>: numeric parameter which specifies the delay class

0 : Subscribed

1 : Delay class 1

2 : Delay class 2

3 : Delay class 3

4 : Delay class 4

Delay Class	Delay (maximum values)			
	SDU size: 128 bytes		SDU size: 1024 bytes	
	Mean Transfer Delay (sec)	95 percentile Delay (sec)	Mean Transfer Delay (sec)	95 percentile Delay (sec)
0	Subscribed	Subscribed by the Nwk / default if value is omitted		
1. (Predictive)	< 0.5	< 1.5	< 2	< 7
2. (Predictive)	< 5	< 25	< 15	< 75
3. (Predictive)	< 50	< 250	< 75	< 375
4. (Best Effort)	Unspecified			

29th September 2004

<reliability>: numeric parameter which specifies the reliability class

- 0 : Subscribed
- 1 : Up to 1 000 (8 kbit/s).
- 2 : Up to 2 000 (16 kbit/s).
- 3 : Up to 4 000 (32 kbit/s).
- 4 : Up to 8 000 (64 kbit/s).
- 5 : Up to 16 000 (128 kbit/s).
- 6 : Up to 32 000 (256 kbit/s).
- 7 : Up to 64 000 (512 kbit/s).
- 8 : Up to 128 000 (1 024 kbit/s).
- 9 : Up to 256 000 (2 048 kbit/s).

Reliability Class	GTP Mode	LLC Frame Mode	LLC Data Protection	RLC Block Mode	Traffic Type
0	Subscribed	Subscribed by the Nwkw / default if value is omitted			
1	Acknowledged	Acknowledged	Protected	Acknowledged	Non real-time traffic, error-sensitive application that cannot cope with data loss.
2	Unacknowledged	Acknowledged	Protected	Acknowledged	Non real-time traffic, error-sensitive application that can cope with infrequent data loss.
3	Unacknowledged	Unacknowledged	Protected	Acknowledged	Non real-time traffic, error-sensitive application that can cope with data loss, GMM/SM, and SMS.
4	Unacknowledged	Unacknowledged	Protected	Unacknowledged	Real-time traffic, error-sensitive application that can cope with data loss.
5	Unacknowledged	Unacknowledged	Unprotected	Unacknowledged	Real-time traffic, error non-sensitive application that can cope with data loss.
NOTE: For real-time traffic, the QoS profile also requires appropriate settings for delay and throughput.					

29th September 2004

<peak>: numeric parameter which specifies the peak throughput class

- 0 : Subscribed
- 1 : Up to 1 000 (8 kbit/s).
- 2 : Up to 2 000 (16 kbit/s).
- 3 : Up to 4 000 (32 kbit/s).
- 4 : Up to 8 000 (64 kbit/s).
- 5 : Up to 16 000 (128 kbit/s).
- 6 : Up to 32 000 (256 kbit/s).
- 7 : Up to 64 000 (512 kbit/s).
- 8 : Up to 128 000 (1 024 kbit/s).
- 9 : Up to 256 000 (2 048 kbit/s).

<mean>: numeric parameter which specifies the mean throughput class

- 0 : Subscribed by the Nwk / default if value is omitted
- 1 : 100 (~0.22 bit/s).
- 2 : 200 (~0.44 bit/s).
- 3 : 500 (~1.11 bit/s).
- 4 : 1 000 (~2.2 bit/s).
- 5 : 2 000 (~4.4 bit/s).
- 6 : 5 000 (~11.1 bit/s).
- 7 : 10 000 (~22 bit/s).
- 8 : 20 000 (~44 bit/s).
- 9 : 50 000 (~111 bit/s).
- 10 : 100 000 (~0.22 kbit/s).
- 11 : 200 000 (~0.44 kbit/s).
- 12 : 500 000 (~1.11 kbit/s).
- 13 : 1 000 000 (~2.2 kbit/s).
- 14 : 2 000 000 (~4.4 kbit/s).
- 15 : 5 000 000 (~11.1 kbit/s).
- 16 : 10 000 000 (~22 kbit/s).
- 17 : 20 000 000 (~44 kbit/s).
- 18 : 50 000 000 (~111 kbit/s).
- 31 : Best effort.

If a value is omitted for a particular class, then it is considered to be unspecified.

17.3 Quality of Service Profile (Minimum acceptable) +CGQMIN

17.3.1 Description

This command allows the TE to specify a minimum acceptable profile which is checked by the MT against the negotiated profile returned in the Activate PDP Context Accept message.

The set command specifies a profile for the context identified by the local context identification parameter, <cid>. Since this is the same parameter that is used in the +CGDCONT command, the +CGQMIN command is an extension to the +CGDCONT command. The QoS profile consists of a number of parameters, each of which may be set to a separate value.

A special form of the set command, +CGQMIN= <cid> causes the minimum acceptable profile for context number <cid> to become undefined. In this case no check is made against the negotiated profile.

The read command returns the current settings for each defined context.

The test command returns values supported as a compound value. If the MT supports several PDP types, the parameter value ranges for each PDP type are returned on a separate line.

29th September 2004

17.3.2 Syntax

Command	Possible Response(s)
AT+CGQMIN=[<cid> [,<precedence > [,<reliability.> [,<mean>]]]]	OK ERROR
AT+CGQMIN?	+CGQMIN: <cid>, <precedence >, <delay>, <reliability>,<peak>,<mean> [<CR><LF>+CGQMIN: <cid>, <precedence >, <delay>, <reliability.>, <peak>, <mean> [...]] OK
AT+CGQMIN=?	+CGQMIN: <PDP type>, (list of supported <precedence>s), (list of supported <delay>s), (list of supported <reliability>s) , (list of supported <peak>s), (list of supported <mean>s) [<CR><LF>+CGQMIN: <PDP type>, (list of supported <precedence>s), (list of supported <delay>s), (list of supported <reliability>s) , (list of supported <peak>s), (list of supported <mean>s) [...]] OK
AT +CGQMIN=1,1,4,5,2,31	OK
AT+CGQMIN=?	+CGQMIN:"IP", (1-3), (1-4), (1-5), (1-9), (1-31) +CGQMIN:"PPP", (1-3), (1-4), (1-5), (1-9), (1-31) OK
AT+CGQMIN?	+CGQMIN: 1,1,4,5,2,14 OK

17.3.3 Defined values

<cid>: a numeric parameter which specifies a particular PDP context .

<precedence>: a numeric parameter which specifies the precedence class.

<delay>: a numeric parameter which specifies the delay class.

<reliability>: a numeric parameter which specifies the reliability class.

<peak>: a numeric parameter which specifies the peak throughput class.

<mean>: a numeric parameter which specifies the mean throughput class.

If a value is omitted for a particular class then this class is not checked.

29th September 2004

17.4 GPRS attach or detach +CGATT

17.4.1 Description

The execution command is used to attach the MT to, or detach the MT from the GPRS service. After the command has completed, the MT remains in V.25ter command state. If the MT is already in the requested state, the command is ignored and the OK response is returned. If the requested state cannot be achieved because the GPRS is not supported by the an ERROR or +CME ERROR response is returned. Extended error responses are enabled by the +CMEE command.

Any active PDP contexts will be automatically deactivated when the attachment state changes to detached.

The read command returns the current GPRS service state.

The test command is used for requesting information on the supported GPRS service states.

17.4.2 Syntax

Command	Possible Response(s)
AT+CGATT= [<state>]	OK ERROR
AT+CGATT?	+CGATT: <state> OK
AT+CGATT=?	+CGATT: (list of supported <state>s) OK
AT +CGATT=1	OK

17.4.3 Defined Values

<state>: indicates the state of GPRS attachment

- 0: detached
- 1: attached
- 2: combined detach (GPRS and GSM detach performed in the same network request)

29th September 2004

- Other values are reserved and will result in an ERROR response to the execution command.

17.5 PDP context activate or deactivate +CGACT

17.5.1 Description

The execution command is used to activate or deactivate the specified PDP context(s). After the command has completed, the MT remains in V.25ter command state. If any PDP context is already in the requested state, the state for that context remains unchanged.

If the requested state for any specified context cannot be achieved, an ERROR or +CME ERROR response is returned. Extended error responses are enabled by the +CMEE command.

If the MT is not GPRS attached when the activation form of the command is executed, the MT first performs a GPRS attach and then attempts to activate the specified contexts. If the attach fails then the MT responds with ERROR or, if extended error responses are enabled, with the appropriate failure-to-attach error message.

If no <cid>s are specified the activation form of the command activates the first activable defined contexts.

If no <cid>s are specified the deactivation form of the command deactivates all active contexts.

One PDP contexts can be activated through Wavecom software at the same time.

The read command returns the current activation states for all the defined PDP contexts.

The test command is used for requesting information on the supported PDP context activation states.

17.5.2 Syntax

Command	Possible Response(s)
AT+CGACT=[<state> [,<cid>[,<cid>[,...]]]]	OK ERROR
AT+CGACT?	+CGACT: <cid>, <state> [<CR><LF>+CGACT: <cid>, <state> [...]] OK
AT+CGACT=?	+CGACT: (list of supported <state>s) OK
AT +CGACT=1,1	OK
AT+CGACT?	+CGACT: 1, 1 OK
AT+CGACT=?	+CGACT: (0-1) OK

17.5.3 Defined Values

<state>: indicates the state of PDP context activation

- 0 : deactivated
- 1 : activated
- Other values are reserved and will result in an ERROR response to the execution command.

<cid>: a numeric parameter which specifies a particular PDP context.

Before the activation of the context, the MT has to attach itself to the GPRS network if necessary.

Note: If a GPRS PPP session is already running, the setting of a CSD (GSM data call) is not supported.

17.6 Enter data state +CGDATA

17.6.1 Description

This command causes the MT to perform the necessary actions to set up communication between the TE and the network. This may include performing a GPRS attach and one PDP context activation.

29th September 2004

If the <cid> value is not defined to the MT, it will return an ERROR or +CME ERROR response. Otherwise, the MT issues the intermediate result code CONNECT and enters V.25ter online data state.

GPRS attachment and PDP context activation procedures may take place prior to or during the PDP startup if they have not already been performed using the +CGATT and +CGACT commands.

If no <cid> is given, the MT attempts to activate the context with available information. The other context parameters are set to their default values (No APN, default QOS parameters, dynamic IP address requested).

If the activation is successful, data transfer may proceed.

After data transfer and layer 2 protocol termination procedure completion, the V.25ter command state is re-entered and the MT returns the final result code OK.

In case of abnormal termination or start up, the V.25ter command state is re-entered and the MT returns the final result code NO CARRIER or, if enabled, +CME ERROR. Attach, activate and other errors may be reported.

This command may be used in both normal and modem compatibility modes.

Notes:

- This command has the same effects than ATD*99***.
- If a GPRS PPP session is already running, the setting of a CSD (GSM data call) is not supported.

17.6.2 Syntax

Command	Possible Response(s)
AT+CGDATA=[<cid>]	CONNECT ERROR
AT+CGDATA=?	+CGDATA: OK

29th September 2004

AT+CGDATA=?	+CGDATA: OK
AT +CGDATA=1	CONNECT

17.6.3 Defined Values

<cid>: a numeric parameter which specifies a particular PDP context definition.

17.7 GPRS mobile station class +CGCLASS

17.7.1 Description

The set command is used to set the MT to operate according to the specified GPRS mobile class. If the requested class is not supported, an ERROR or +CME ERROR response is returned.

The read command returns the current GPRS mobile class.

The test command is used for requesting information on the supported GPRS mobile classes.

17.7.2 Syntax

Command	Possible Response(s)
AT+CGCLASS= [<class>]	OK ERROR
AT+CGCLASS?	+CGCLASS: <class> OK
AT+CGCLASS=?	+CGCLASS: (list of supported <class>s) OK
AT +CGCLASS="CG" <i>Note : Enter GPRS class C mode</i>	OK
AT +CGCLASS="CC" <i>Note : Enter GSM mode</i>	OK
AT +CGCLASS="A" <i>Note : Chosen class not supported.</i>	+CME ERROR: 150

29th September 2004

AT+CGCLASS=?	+CGCLASS: ("CG","CC") OK
AT+CGCLASS?	+CGCLASS: "CC" OK

17.7.3 Defined Values

<class>: a string parameter which indicates the GPRS mobile class (in descending order of functionality)

- A class A (highest)
- B class B
- CG class C in GPRS only mode
- CC class C in circuit switched only mode (lowest)

Other values are reserved and will result in an ERROR response to the set command.

If the MT is GPRS attached when the set command is issued with a <class> = CC specified, a GPRS detach request is sent to the network.

If the MT is GSM attached when the set command is issued with a <class> = CG specified, a GSM detach request is sent to the network.

Class A is not supported by Wavecom GPRS software.

Remark : During switch-On in CG class, the MS always performs an automatic GPRS attach (the ATTACH-STATUS parameter of +WGPRS is ignored).

But if the MS is not already GPRS attached when switching from B/CC class to CG class then no automatic GPRS attach is performed.

29th September 2004

Example about automatic attachment (see remark above) :

```
AT+CGCLASS?
+CGCLASS: "B"
OK
AT+CGATT?
+CGATT: 0
OK
AT+CGCLASS="CG"
OK
AT+CGATT?
+CGATT: 0
OK
AT+CGATT=1
OK
AT+CPOF
OK
AT+CFUN=1
OK
AT+CGCLASS?
+CGCLASS: "CG"
OK
AT+CGATT?
+CGATT: 1
OK
```

17.8 Select service for MO SMS messages +CGSMS

17.8.1 Description

The set command is used to specify the service or service preference that the MT will use to send MO SMS messages.

The read command returns the currently selected service or service preference.

29th September 2004

The test command is used for requesting information on the currently available services and service preferences.

17.8.2 Syntax

Command	Possible Response(s)
+CGSMS= [<service>]	OK ERROR
+CGSMS?	+CGSMS: <service> OK
+CGSMS=?	+CGSMS: (list of currently available <service>s) OK
AT +CGSMS=0	OK
AT+CGSMS=?	+CGSMS: (0-3) OK

17.8.3 Defined Values

<service>: a numeric parameter which indicates the service or service preference to be used

- 0 : GPRS
- 1 : Circuit switched
- 2 : GPRS preferred (use circuit switched if GPRS is not available)
- 3 : Circuit switched preferred (use GPRS if circuit switched not available)
- Other values are reserved and will result in an ERROR response to the set command.

29th September 2004

17.9 GPRS event reporting +CGEREP

17.9.1 Description

Set command enables or disables sending of unsolicited result codes, +CGEV: XXX from MT to TE in the case of certain events occurring in the GPRS MT or the network.

<mode> controls the processing of unsolicited result codes specified within this command.

Read command returns the current mode and buffer settings

Test command returns the modes and buffer settings supported by the MT as compound values.

17.9.2 Syntax

Command	Possible response(s)
+CGEREP=[<mode>]	OK ERROR
+CGEREP?	+CGEREP: <mode>,<bfr> OK
+CGEREP=?	+CGEREP: (list of supported <mode>s), (list of supported <bfr>s) OK

17.9.3 Defined values

<mode>:

- 0 : buffer unsolicited result codes in the MT; if MT result code buffer is full, the oldest ones can be discarded. No codes are forwarded to the TE.
- 2 : buffer unsolicited result codes in the MT when MT-TE link is reserved (e.g. in on-line data mode) and flush them to the TE when MT-TE link becomes available; otherwise forward them directly to the TE

<bfr>

29th September 2004

- 0 : MT buffer of unsolicited result codes defined within this command is cleared when <mode> 1 or 2 entered. Only this case is supported by Wavecom.
- 1 : MT buffer of unsolicited result codes defined within this command is flushed to the TE when <mode> 2 is entered. This case is not supported by Wavecom.

With Wavecom's software, a combinaison of all modes is implemented. When serial link is available, indications are forwarded directly to the TE. If serial link is reserved (e.g. in on-line data mode), if MT result code buffer is full, the oldest ones can be discarded.

29th September 2004

Defined events

The following unsolicited result codes and the corresponding events are defined:

+CGEV: REJECT <PDP_type>, <PDP_addr>

A network request for PDP context activation occurred when the MT was unable to report it to the TE with a +CRING unsolicited result code and was automatically rejected.

+CGEV: NW REACT <PDP_type>, <PDP_addr>, [<cid>]

The network has requested a context reactivation. The <cid> that was used to reactivate the context is provided if known to the MT.

+CGEV: NW DEACT <PDP_type>, <PDP_addr>, [<cid>]

The network has forced a context deactivation. The <cid> that was used to activate the context is provided if known to the MT.

+CGEV: ME DEACT <PDP_type>, <PDP_addr>, [<cid>]

The mobile equipment has forced a context deactivation. The <cid> that was used to activate the context is provided if known to the MT.

+CGEV: NW DETACH

The network has forced a GPRS detach. This implies that all active contexts have been deactivated. These are not reported separately.

+CGEV: ME DETACH

The mobile equipment has forced a GPRS detach. This implies that all active contexts have been deactivated. These are not reported separately.

+CGEV: NW CLASS <class>

The network has forced a change of MS class. The highest available class is reported.

+CGEV: ME CLASS <class>

The mobile equipment has forced a change of MS class. The highest available class is reported.

29th September 2004

17.10 GPRS network registration status +CGREG

17.10.1 Description

The set command controls the presentation of an unsolicited result code +CGREG: <stat> when <n>=1 and there is a change in the MT's GPRS network registration status, or code +CGREG: <stat>[,<lac>,<ci>] when <n>=2 and there is a change of the network cell.

The read command returns the status of result code presentation and an integer <stat> which shows whether the network has currently indicated the registration of the MT. Location information elements <lac> and <ci> are returned only when <n>=2 and MT is registered in the network.

17.10.2 Syntax

Command	Possible response(s)
AT+CGREG=[<n>]	OK +CGREG: stat>[,<lac>,<ci>]
AT+CGREG?	+CGREG: <n>,<stat>[,<lac>,<ci>] OK <i>+CME ERROR: <err></i>
AT+CGREG=?	+CGREG: (list of supported <n>s) OK

17.10.3 Defined values

<n>:

0 : disable network registration unsolicited result code

1 : enable network registration unsolicited result code +CGREG: <stat>

2 : enable network registration and location information unsolicited result code +CGREG: <stat>[,<lac>,<ci>]

<stat>:

0 : not registered, ME is not currently searching a new operator to register to

1 : registered, home network

29th September 2004

2 : not registered, but ME is currently searching a new operator to register to

3 : registration denied

4 : unknown

5 : registered, roaming

<lac>:

string type; two byte location area code in hexadecimal format.

<ci>:

string type; two byte cell ID in hexadecimal format

17.11 Request GPRS IP service 'D'

17.11.1 Description

This command causes the MT to perform whatever actions are necessary to establish communication between the TE and the external PDN.

The V.25ter 'D' (Dial) command causes the MT to enter the V.25ter online data state and, with the TE, to start the specified layer 2 protocol. The MT return CONNECT to confirm acceptance of the command prior to entering the V.25ter online data state. No further commands may follow on the AT command line.

The detailed behaviour after the online data state has been entered is described briefly in clause 9, for IP, of GSM 07.60. GPRS attachment and PDP context activation procedures may take place prior to or during the PDP startup if they have not already been performed using the +CGATT and +CGACT commands.

If <cid> is supported, its usage is the same as in the +CGDATA command. The +CGDCONT, +CGQREQ, etc. commands may then be used in the modem initialisation AT command string to set values for for PDP type, APN, QoS etc...

If <cid> is not supported or is supported but omitted, the MT attempt to activate the context using the 'Empty PDP type' (GSM 04.08). (No PDP address or APN is sent in this case and only one PDP context subscription record is present in the HLR for this subscriber.)

29th September 2004

Note: If a GPRS PPP session is already running, the setting of a CSD (GSM data call) is not supported.

17.11.2 Syntax

Command	Possible Response(s)
D* <GPRS_SC_IP>[*** <cid>]#	CONNECT ERROR

17.11.3 Defined Values

<GPRS_SC_IP>: (GPRS Service Code for IP) a digit string (value 99), which identifies a request to use the GPRS with IP (PDP types IP and PPP)

<cid>: a digit string which specifies a particular PDP context definition.

Example

```
ATD*99***1#
```

```
CONNECT
```

```
ATD*99***2#
```

```
ERROR
```

17.12 Network requested PDP context activation

In this mode of operation, the MT behaves like an answering modem and accepts the normal V.25ter commands associated with answering a call. If GPRS-specific configuration commands are required, they may be sent to the MT as part of the modem initialisation commands.

The +CGAUTO command is used to select modem compatibility mode.

17.12.1 Automatic response to a network request for PDP context activation 'S0'

The V.25ter 'S0=n' (Automatic answer) command may be used to turn off (n=0) and on (n>0) the automatic response to a network request for a PDP context activation.

When the 'S0=n' (n>0) command is received, the MT attempt to perform a GPRS attach if it is not already attached. Failure will result in ERROR being

29th September 2004

returned to the TE. Subsequently, the MT will announce a network request for PDP context activation by issuing the unsolicited result code RING to the TE, followed by the intermediate result code CONNECT. The MT then enters V.25ter online data state and follows the same procedure as it would after having received a +CGANS=1 with no <L2P> or <cid> values specified.

NOTE: The 'S0=n' (n=0) command does not perform an automatic GPRS detach.

17.12.2 Manual acceptance of a network request for PDP context activation 'A'

The V.25ter 'A' (Answer) command may be used to accept a network request for a PDP context activation announced by the unsolicited result code RING. The MT responds with CONNECT, enters V.25ter online data state and follows the same procedure as it would after having received a +CGANS=1 with no <cid> value specified. It is an error to issue the 'A' command when there is no outstanding network request.

17.12.3 Manual rejection of a network request for PDP context activation 'H'

The V.25ter 'H' or 'H0' (On-hook) command may be used to reject a network request for PDP context activation announced by the unsolicited result code RING. The MT responds with OK. It is an error to issue the 'H' command when there is no outstanding network request.

NOTE: This is an extension to the usage of the 'H' command that is described in ITU-T V.25ter.

17.13 Automatic response to a network request for PDP context activation +CGAUTO

17.13.1 Description

The set command disables or enables an automatic positive response (auto-answer) to the receipt of a Request PDP Context Activation message from the network. It also provides control over the use of the V.25ter basic commands 'S0', 'A' and 'H' for handling network requests for PDP context activation. The setting does not affect the issuing of the unsolicited result code RING or +CRING.

The test command returns values of <n> supported by the MT as a compound value.

29th September 2004

When the +CGAUTO=0 command is received, the MT will not perform a GPRS detach if it is attached. Subsequently, when the MT announces a network request for PDP context activation by issuing the unsolicited result code RING or +CRING, the TE may manually accept or reject the request by issuing the +CGANS command or may simply ignore the network request.

When the +CGAUTO=1 command is received, the MT will attempt to perform a GPRS attach if it is not already attached. Failure will result in ERROR or, if enabled, +CME ERROR being returned to the TE. Subsequently, when the MT announces a network request for PDP context activation by issuing the unsolicited result code RING or +CRING to the TE, this is followed by the intermediate result code CONNECT. The MT then enters V.25ter online data state and follows the same procedure as it would after having received a +CGANS=1 with <cid> values specified.

17.13.2 Syntax

Command	Possible response(s)
+CGAUTO=[<n>]	OK ERROR
+CGAUTO?	+CGAUTO: <n> OK
+CGAUTO=?	+CGAUTO: (0-3) OK

17.13.3 Defined values

<n>:

- 0 turn off automatic response for GPRS only
- 1 turn on automatic response for GPRS only
- 2 modem compatibility mode, GPRS only
- 3 modem compatibility mode, GPRS and circuit switched calls (default)

For <n> = 0 GPRS network requests are manually accepted or rejected by the +CGANS command.

For <n> = 1 GPRS network requests are automatically accepted according to the description above.

For <n> = 2, automatic acceptance of GPRS network requests is controlled by the 'S0' command. Manual control uses the 'A' and 'H' commands, respectively, to accept and reject GPRS requests. (+CGANS may also be used.) Incoming circuit switched calls can be neither manually nor automatically answered.

29th September 2004

For <n> = 3, automatic acceptance of both GPRS network requests and incoming circuit switched calls is controlled by the 'S0' command. Manual control uses the 'A' and 'H' commands, respectively, to accept and reject GPRS requests. (+CGANS may also be used.) Circuit switched calls are handled as described elsewhere in this specification.

NOTE. In class C GPRS the modem can't receive simultaneously GPRS and GSM incoming calls.

Example

AT+CGAUTO=?

+CGAUTO: (0-2)

OK

AT+CGAUTO?

+CGAUTO: 2

OK

AT+CGAUTO=0

OK

17.14 Manual response to a network request for PDP context activation +CGANS**17.14.1 Description**

The execution command requests the MT to respond to a network request for GPRS PDP context activation which has been signalled to the TE by the RING or +CRING: unsolicited result code. The <response> parameter allows the TE to accept or reject the request.

If <response> is 0, the request is rejected and the MT returns OK to the TE.

If <response> is 1, the following procedure is followed by the MT.

PDP context activation procedures take place prior to or during the PDP startup.

One <cid> may be specified in order to provide the values needed for the context activation request.

29th September 2004

During the PDP startup procedure the MT has the PDP type and the PDP address provided by the network in the Request PDP Context Activation message.

If a <cid> is given his informations must matching with the PDP type and PDP address in the network request as follows –

The PDP type must match exactly.

The PDP addresses are considered to match if they are identical or if the address in the context definition is unspecified.

If any of this information is in conflict, the command will fail.

The context is activated using the values for PDP type and PDP address provided by the network, together with the other information found in the PDP context definition. An APN may or may not be required, depending on the application.

If no <cid> is given, the MT will attempt to activate the context using the values for PDP type and PDP address provided by the network, together with any other relevant information known to the MT. The other context parameters will be set to their default values.

If the activation is successful, data transfer may proceed.

After data transfer is complete, and the layer 2 protocol termination procedure has completed successfully, the V.25ter command state is re-entered and the MT returns the final result code OK

In the event of an erroneous termination or a failure to startup, the V.25ter command state is re-entered and the MT returns the final result code NO CARRIER or, if enabled, +CME ERROR. Attach, activate and other errors may be reported. It is also an error to issue the +CGANS command when there is no outstanding network request.

This command may be used in both normal and modem compatibility modes.

17.14.2 Syntax

Command	Possible response(s)
+CGANS=[<response>, [<cid>]]	OK ERROR
+CGANS=?	+CGANS: (list of supported <response>s), (list of supported <L2P>s) OK

17.14.3 Defined values

<response>: is a numeric parameter which specifies how the request should be responded to.

0 reject the request

1 accept and request that the PDP context be activated

If **<response>** is omitted it is assumed to be 0. Other values are reserved and will result in the ERROR response.

<cid>: a numeric parameter which specifies a particular PDP context definition.

Example

```
+CRING: GPRS "IP", "122.41.74.238"
AT+CGANS=1
CONNECT
AT+CGANS=?
+CGANS: (0-1)
OK
```

17.15 Show PDP address +CGPADDR

17.15.1 Description

The execution command returns a list of PDP addresses for the specified context identifiers.

The test command returns a list of defined **<cid>**s

17.15.2 Syntax

Command	Possible response(s)
+CGPADDR=[<cid> [,<cid> [...]]]	+CGPADDR: <cid>,<PDP_addr> [<CR><LF>+CGPADDR: <cid>,<PDP_addr> [...]] OK

29th September 2004

+CGPADDR=?	+CGPADDR: (list of defined <cid>s) OK
------------	--

17.15.3 Defined values

<cid>: a numeric parameter which specifies a particular PDP context definition. If no <cid> is specified, the addresses for all defined contexts are returned.

<PDP_address>: a string that identifies the MT in the address space applicable to the PDP. The address may be static or dynamic. For a static address, it will be the one set by the +CGDCONT command when the context was defined. For a dynamic address it will be the one assigned during the last PDP context activation that used the context definition referred to by <cid>. <PDP_address> is omitted if none is available.

Example

In this example 3 Cids are defined.

```
AT+CGPADDR=1
+CGPADDR=1,"107.210.5.4"
OK
```

```
AT+CGPADDR=?
+CGPADDR: (1,2,4)
OK
```

```
AT+CGPADDR
+CGPADDR: 1,
+CGPADDR: 2,"10.3.73.151"
+CGPADDR: 4,
```

17.16 Cellular result codes +CRC

17.16.1 Description

This command enables a more detailed ring indication, in case of incoming call (voice or data). Instead of the string "RING", an extended string is used to indicate which type of call is ringing (e.g. +CRING: VOICE).

wavecom confidential ©

Page : 366 / 460

This document is the sole and exclusive property of WAVECOM. Not to be distributed or divulged without prior written agreement. Ce document est la propriété exclusive de WAVECOM. Il ne peut être communiqué ou divulgué à des tiers sans son autorisation préalable.

29th September 2004

These extended indications are :

+CRING: ASYNC	for asynchronous transparent
+CRING: REL ASYNC	for asynchronous non-transparent
+CRING: VOICE	for normal speech.
+CRING : FAX	for fax calls
+CRING: GPRS	GPRS network request for PDP context activation

If the MT is unable to announce to the TE the network's request (for example it is in V.25ter online data state) the MT rejects the request. No corresponding unsolicited result code is issued when the MT returns to a command state.

17.16.2 Syntax

See 11.5

17.16.3 Defined values

No parameter.

17.17 Service reporting control +CR

17.17.1 Description

This command enables a more detailed service reporting, in case of data **incoming or outgoing call**. Before sending the CONNECT response to the application, the GSM module will precise the type of data connection that have been established.

These report types are :

+CR: ASYNC	For asynchronous transparent
+CR: REL ASYNC	For asynchronous non-transparent
+CR: GPRS	For GPRS

29th September 2004

17.17.2 Syntax

Command syntax : AT+CR

Command	Possible responses
AT+CR=0 <i>Note : Extended reports disabled</i>	OK <i>Note : Command valid</i>
AT+CR=1 <i>Note : Extended reports enabled</i>	OK <i>Note : Command valid</i>

17.17.3 Defined values

No parameter.

17.18 Extended error report +CEER

17.18.1 Description

This command gives the reason of the call release when the last call setup (originating or answering) failed.

New indication for GPRS is the reason of the last unsuccessful PDP context activation and the last GPRS detach or PDP context activation.

17.18.2 Syntax

Command syntax : AT+CEER

Command	Possible responses
ATD123456789 ; <i>Note : Outgoing voice call</i>	NO CARRIER <i>Note : Call setup failure</i>
AT+CEER <i>Note : Ask for reason of release</i>	+CEER : Error <xxx> OK <i>Note : <xxx>is the cause information element values form GSM recommandation 04.08 or specific Call accepted</i>

The cause information element from GSM 04.08 is given below in § 19.4 Specific Failure Cause for +CEER for specific GPRS failure causes.

The "NO CARRIER" indicates that the AT+CEER information is available for a failure diagnostic.

29th September 2004

17.18.3 Defined values

No parameters.

17.19 GPRS parameters customization: +WGPRS**17.19.1 Description**

This command modifies some Wavecom GPRS parameters :

- the ATTACH-STATUS (the ME does or not perform automatically a GPRS attachment after initialisation),
- the PDP-INIT-STATUS (declare some PDP contexts liable to be activated automatically after initialization) and
- the user-defined multislot class. This parameter represents the GPRS class chosen by the user to perform power saving (by reducing TX (or uplink) time slots).

In addition, this command permits to

- set automatically "ACTIVABLE" some defined PDP contexts after initialization,
- set some parameters for PALM® OS software: PPP Silent Mode (PPP waits for PPP Client to start the dialog) and Slow CONNECT (due to the delay of the processing of PALM® OK, the CONNECT is sent one second after the dialing command request)

IMPORTANT NOTE : The WISMO module must be rebooted to activate the new setup except for <mode> 3, 5 and 6 (please refer to Defined Values paragraph).

29th September 2004

17.19.2 Syntax

Command syntax : AT+WGPRS=<mode>,<parameter>,[<cid>],[<class>]

Command	Possible responses
AT+WGPRS=?	+WGPRS: <mode>, <parameter1>,[<cid>] [<CR><LF>+WGPRS: <mode>, <parameter>,[<cid>] [...]] OK
AT+WGPRS?	+WGPRS:<mode>(list of supported <parameter>),[(list of supported <cid>)][<CR><LF>+WGPRS:<mode>(list of supported <parameter>),[(list of supported <cid>)] [...]] OK
AT+WGPRS=2,1,3 <i>Note: set ACTIVABLE to ON on PDP context 3</i>	OK
AT+WGPRS=4,,,8 <i>Note: choose GPRS multislots class 8</i>	OK
AT+WGPRS=? <i>Note: Request ranges of values</i>	+WGPRS: (0-6),(0-1),(0-4),(2,8,10,12) OK
AT+WGPRS?	+WGPRS: 0,0 +WGPRS: 1,0 +WGPRS: 2,1,1 +WGPRS: 2,0,2 +WGPRS: 2,0,3 +WGPRS: 2,0,4 +WGPRS: 3,1 +WGPRS:4,8 +WGPRS:5,1 +WGPRS:6,1 OK

29th September 2004

17.19.3 Defined Values

<mode>: a numeric parameter which specifies a Wavecom GPRS parameter.

- 0 ATTACH-STATUS (the ME don't make automatically a GPRS attachment after init)
- 1 PDP-INIT-STATUS (declare some PDP contexts liable to be activated automatically after initialization by <mode>=2)
- 2 Set ACTIVABLE automatically after init a define PDP context
- 3 PPP silent mode
- 4 definition of the GPRS multislot class.
- 5 Slow CONNECT for PALM® OS
- 6 PPP Filtering

Notes:

- 1. If <mode>=0, 1, 3, 4, 5 or 6, <cid> and <class> values will be ignored.
- 2. If <mode>=0, 1, 2, 3, 5 or 6, <class> value will be ignored.
- 3. If <mode>=4, <parameter> and <cid> values will be ignored. WISMO module must be restarted to take the modification into account.
- 4. PPP Filtering is a test-purpose functionality. It avoids sending on the radio link some OS-specific frames, for accurate transfer rate measurements.

<parameter> : a numeric parameter that controls the operation defined by <mode> if it is equal to 0, 1, 2, 3, 5 or 6.

- 0 operation OFF (disabled)
- 1 operation ON (enabled)

<cid> : (PDP Context Identifier) a numeric parameter which specifies a particular PDP context definition. The parameter is local to the TE-MT interface and is used in other PDP context-related commands. Range of values is 0 to 4.

<class>

GPRS multislot class number. It may be lower than the maximum possible class. Possible values are 2, 8, 10, 12. Refer to doc ref [6] for more information about GPRS multislot classes. Note that the range of values is also WISMO-module-dependant.

29th September 2004

Multislot class	Maximum number of slots			Minimum number of slots				Type of MS
	Rx	Tx	Sum	T _{ta}	T _{tb}	T _{ra}	T _{rb}	
2	2	1	3	3	2	3	1	1
8	4	1	5	3	1	2	1	1
10	4	2	5	3	1	2	1	1
12	4	4	5	2	1	2	1	1

NB: Type 1 MS are not required to transmit and receive at the same time.

Remark

When the module is set in "CG" class, the ME always make automatically a GPRS attachment after init, so AT+WGPRS? always give +WGPRS: 0,0 for the parameter 0.

29th September 2004

17.20 Full AT GPRS commands examples

17.20.1 Activation of an IP PDP context

Example 1 :

```
AT +CGDCONT=1, "IP", "internet"; +GCDCONT=2, "IP", "abc.com"
```

```
OK
```

```
ATD*99***1#
```

```
CONNECT
```

Example 2 :

```
AT +CGCLASS="CG"
```

```
OK
```

```
+CGREG: 1
```

```
AT +CGDCONT=1, "IP", "internet"
```

```
OK
```

```
AT +CGQREQ=1,1,4,5,2,14
```

```
OK
```

```
AT +CGQMIN=1,1,4,5,2,14
```

```
OK
```

```
AT +CGATT=1
```

```
OK
```

```
AT +CGACT=1,1
```

```
OK
```

*Remark about +CGDATA : the goal of this command is the same than
ATD*99****

```
AT +CGDATA=1
```

```
CONNECT
```

```
.....
```

Data transfer

```
.....
```

```
+CGEV: NW DETACH
```

17.20.2 Network request

```
AT+CGAUTO=0
```

29th September 2004

OK

+CRING: GPRS "IP", "211.45.89.152"

AT+CGANS=1

CONNECT

.....*Data transfer*

18 Other AT commands

18.1 V.25 ter recommendation

The commands not listed in this document are not supported. For these commands, the product will then answer with "ERROR".

All modulation control, error control and data compression commands are not recognized. An "ERROR" string will be returned.

18.2 GSM 07.05 recommendation

All the 07.05 commands not described in this manual are not implemented. The product will then answer "ERROR" to these commands.

18.3 GSM 07.07 recommendation

All the 07.07 commands not described in this manual are not implemented. The product will then answer "ERROR" to these commands.

19 Appendixes

19.1 ME error result code : +CME ERROR: <error>

<error>	Meaning	Resulting from the following commands
3	Operation not allowed	All GSM 07.07 commands (+CME ERROR: 3)
4	Operation not supported	All GSM 07.07 commands (+CME ERROR: 4)
5	PH-SIM PIN required (SIM lock)	All GSM 07.07 commands (+CME ERROR: 5)
10	SIM not inserted	All GSM 07.07 commands (+CME ERROR: 10)
11	SIM PIN required	All GSM 07.07 commands (+CME ERROR: 11)
12	SIM PUK required	All GSM 07.07 commands (+CME ERROR: 12)
13	SIM failure	All GSM 07.07 commands (+CME ERROR: 13)
16	Incorrect password	+CACM, +CAMM, +CPUC, +CLCK, +CPWD, +CPIN, +CPIN2 (+CME ERROR: 16)
17	SIM PIN2 required	+CPBW (FDN), +CLCK (FDN),
18	SIM PUK2 required	+CACM, +CAMM, +CPUC, +CPBW (FDN), +CPIN, +CPIN2, +CLCK (FDN), +CPWD
20	Memory full	+CPBW
21	Invalid index	+CPBR, +CPBW, ATD>[mem]index, +WMGO
22	Not found	+CPBF, +CPBP, +CPBN, +CGSN, +WOPN, ATD>[mem]"name"
24	Text string too long	+CPBW, +CPIN, +CPIN2, +CLCK, +CPWD, +WCCS
26	Dial string too long	+CPBW, ATD, +CCFC
27	Invalid characters in dial string	+CPBW
30	No network service	+VTS, +COPS=?, +CLCK, +CCFC, +CCWA, +CUSD
32	Network not allowed – emergency calls only	+COPS
40	Network personalization PIN required (Network lock)	All GSM 07.07 commands (+CME ERROR: 40)

29th September 2004

<error>	Meaning	Resulting from the following commands
103	Incorrect MS identity.	+CGATT
106	ME is not blacklisted by the network.	+CGATT
107	MS is not allowed to operate in GPRS.	+CGATT
111	MS is not allowed to operate in the requested PLMN.	+CGATT
112	MS is not allowed to make location updating in this area.	+CGATT
113	Roaming in this location area is not allowed.	+CGATT
132	service option not supported (#32)	+CGACT +CGDATA ATD*99
133	requested service option not subscribed (#33)	+CGACT +CGDATA ATD*99
134	service option temporarily out of order (#34)	+CGACT +CGDATA ATD*99
148	unspecified GPRS error	All GPRS commands
149	PDP authentication failure	+CGACT +CGDATA ATD*99
150	invalid mobile class	+CGCLASS +CGATT

19.2 Message service failure result code: +CMS ERROR : <er>

<er> is defined as below :

<er>	Meaning	Resulting from the following commands
1 to 127	Error cause values from the GSM recommendation 04.11 Annex E-2	+CMGS, +CMSS
301	SMS service of ME reserved	+CSMS (with +CMS: ERROR 301)
302	Operation not allowed	All SMS commands (+CMSS, +CMGL, +CPMS, +CSMP...)
303	Operation not supported	All SMS commands
304	Invalid PDU mode parameter	+CMGS, +CMGW
305	Invalid text mode parameter	+CMGS, +CMGW, +CMSS
310	SIM not inserted	All SMS commands

29th September 2004

<er>	Meaning	Resulting from the following commands
311	SIM PIN required	All SMS commands
312	PH-SIM PIN required	All SMS commands
313	SIM failure	All SMS commands
316	SIM PUK required	All SMS commands
317	SIM PIN2 required	All SMS commands
318	SIM PUK2 required	All SMS commands
321	Invalid memory index	+CMGR, +CMSS, +CMGD
322	SIM memory full	+CMGW
330	SC address unknown	+CSCA?, +CMSS, +CMGS
340	no +CNMA acknowledgement expected	+CNMA

19.3 Specific error result codes

<error>	Meaning	Resulting from the following commands
500	unknown error.	All commands
512	MM establishment failure (for SMS).	+CMGS, +CMSS (+CMS ERROR: 512)
513	Lower layer failure (for SMS)	+CMGS, +CMSS (+CMS ERROR: 513)
514	CP error (for SMS).	+CMGS, +CMSS (+CMS ERROR: 514)
515	Please wait, init or command processing in progress.	All commands (" +CME ERROR: 515" or " +CMS ERROR: 515") except ATH0, ATH1, AT+WIOR, AT+WIOW, AT+CFUN=1, AT+CLCC, AT+WAC, AT+CPAS, AT+VGR, AT+VTS, AT+SPEAKER.
517	SIM Toolkit facility not supported.	+STGI
518	SIM Toolkit indication not received.	+STGI
519	Reset the product to activate or change a new echo cancellation algo.	+ECHO, +VIP
520	Automatic abort about get plmn list for an incoming call.	+COPS=?
526	PIN deactivation forbidden with this SIM card.	+CLCK
527	Please wait, RR or MM is busy. Retry your selection later.	+COPS
528	Location update failure. Emergency calls only.	+COPS
529	PLMN selection failure. Emergency calls only.	+COPS

29th September 2004

<error>	Meaning	Resulting from the following commands
531	SMS not sent : the <da> is not in FDN phonebook, and FDN lock is enabled. (for SMS)	+CMGS, +CMSS (+CMS ERROR: 531)
532	the embedded application is activated so the objects flash are not erased	+WOPEN
533	Missing or Unknown APN	ATD*99 +GACT +CGDATA
539	Invalid SMS	+CMGR

29th September 2004

19.4 Failure Cause from GSM 04.08 recommendation (+CEER)

Cause value	Diagnostic
1	Unassigned (unallocated) number
3	No route to destination
6	Channel unacceptable
8	Operator determined barring
16	Normal call clearing
17	User busy
18	No user responding
19	User alerting, no answer
21	Call rejected
22	Number changed
26	Non selected user clearing
27	Destination out of order
28	Invalid number format (incomplete number)
29	Facility rejected
30	Response to STATUS ENQUIRY
31	Normal, unspecified
34	No circuit/channel available
38	Network out of order
41	Temporary failure
42	Switching equipment congestion
43	Access information discarded
44	Requested circuit/channel not available
47	Resources unavailable, unspecified
49	Quality of service unavailable
50	Requested facility not subscribed
55	Incoming calls barred with in the CUG
57	Bearer capability not authorized
58	Bearer capability not presently available
63	Service or option not available, unspecified
65	Bearer service not implemented
68	ACM equal to or greater than ACMmax
69	Requested facility not implemented
70	Only restricted digital information bearer capability is available
79	Service or option not implemented, unspecified
81	Invalid transaction identifier value
87	User not member of CUG
88	Incompatible destination
91	Invalid transit network selection
95	Semantically incorrect message
96	Invalid mandatory information
97	Message type non-existent or not implemented
98	Message type not compatible with protocol state
99	Information element non-existent or not implemented
100	Conditional IE error
101	Message not compatible with protocol state
102	Recovery on timer expiry
111	Protocol error, unspecified

29th September 2004

Cause value	Diagnostic
127	Interworking, unspecified
224	MS requested detach
225	NWK requested Detach
226	Unsuccessful attach cause NO SERVICE
227	Unsuccessful attach cause NO ACCESS
228	Unsuccessful attach cause GPRS SERVICE REFUSED
229	PDP Deactivation requested by NWK
230	PDP Deactivation because LLC link activation Failed
231	PDP Deactivation cause NWK reactivation with same TI
232	PDP Deactivation cause GMM abort
233	PDP Deactivation cause LLC or SNDTCP failure
234	PDP Unsuccessful activation cause GMM error
235	PDP Unsuccessful activation cause NWK reject
236	PDP Unsuccessful activation cause NO NSAPI available
237	PDP Unsuccessful activation cause SM refuse
238	PDP Unsuccessful activation cause MMI ignore
239	PDP unsuccessful activation cause Nb Max Session Reach

All <u>other</u> values in the range	will be treated as cause
[0,31]	31
[32,47]	47
[48,63]	63
[64,79]	79
[80,95]	95
[96,111]	111
[112,127]	127

19.5 Specific Failure Cause for +CEER

Cause value	Diagnostic
240	FDN is active and number is not in FDN
241	Call operation not allowed
252	Call barring on outgoing calls
253	Call barring on incoming calls
254	Call impossible
255	Lower layer failure

29th September 2004

19.6 GSM 04.11 Annex E-2: Mobile originating SM-transfer

These error causes could appear for **SMS commands** (+CMGS, +CMSS, +CMGD...)

Cause no 1: "Unassigned (unallocated) number"

This cause indicates that the destination requested by the Mobile Station cannot be reached because, although the number is in a valid format, it is not currently assigned (allocated).

Cause no 8: "Operator determined barring"

This cause indicates that the MS has tried to send a mobile originating short message when the MS's network operator or service provider has forbidden such transactions.

Cause no 10: "Call barred"

This cause indicates that the outgoing call barred service applies to the short message service for the called destination.

Cause no 21: "Short message transfer rejected"

This cause indicates that the equipment sending this cause does not wish to accept this short message, although it could have accepted the short message since the equipment sending this cause is neither busy nor incompatible.

Cause no 27: "Destination out of service"

This cause indicates that the destination indicated by the Mobile Station cannot be reached because the interface to the destination is not functioning correctly. The term "not functioning correctly" indicates that a signaling message was unable to be delivered to the remote user; e.g., a physical layer or data link layer failure at the remote user, user equipment off-line, etc.

Cause no 28: "Unidentified subscriber"

This cause indicates that the subscriber is not registered in the PLMN (e.g.. IMSI not known)

Cause no 29: "Facility rejected"

This cause indicates that the facility requested by the Mobile Station is not supported by the PLMN.

Cause no 30: "Unknown subscriber"

This cause indicates that the subscriber is not registered in the HLR (e.g.. IMSI or directory number is not allocated to a subscriber).

Cause no 38: "Network out of order"

This cause indicates that the network is not functioning correctly and that the condition is likely to last a relatively long period of time; e.g., immediately reattempting the short message transfer is not likely to be successful.

29th September 2004

Cause no 41: "Temporary failure"

This cause indicates that the network is not functioning correctly and that the condition is not likely to last a long period of time; e.g., the Mobile Station may wish to try another short message transfer attempt almost immediately.

Cause no 42: "Congestion"

This cause indicates that the short message service cannot be serviced because of high traffic.

Cause no 47: "Resources unavailable, unspecified"

This cause is used to report a resource unavailable event only when no other cause applies.

Cause no 50: "Requested facility not subscribed"

This cause indicates that the requested short message service could not be provided by the network because the user has not completed the necessary administrative arrangements with its supporting networks.

Cause no 69: "Requested facility not implemented"

This cause indicates that the network is unable to provide the requested short message service.

Cause no 81: "Invalid short message transfer reference value"

This cause indicates that the equipment sending this cause has received a message with a short message reference which is not currently in use on the MS-network interface.

Cause no 95: "Invalid message, unspecified"

This cause is used to report an invalid message event only when no other cause in the invalid message class applies.

Cause no 96: "Invalid mandatory information"

This cause indicates that the equipment sending this cause has received a message where a mandatory information element is missing and/or has a content error (the two cases are undistinguishable).

Cause no 97: "Message type non-existent or not implemented"

This cause indicates that the equipment sending this cause has received a message with a message type it does not recognize either because this is a message not defined or defined but not implemented by the equipment sending this cause.

Cause no 98: "Message not compatible with short message protocol state"

This cause indicates that the equipment sending this cause has received a message such that the procedures do not indicate that this is a permissible message to receive while in the short message transfer state.

Cause no 99: "Information element non-existent or not implemented"

This cause indicates that the equipment sending this cause has received a message which includes unrecognized information elements because the information element identifier is not defined or it is defined but not implemented by the equipment sending the cause.

29th September 2004

However, the information element is not required to be present in the message so that the equipment sends the cause to process the message.

Cause no 111: "Protocol error, unspecified"

This cause is used to report a protocol error event only when no other cause applies.

Cause no 127: "Interworking, unspecified"

This cause indicates that there has been interworking with a network which does not provide causes for actions it takes; thus, the precise cause for a message which is being sent cannot be ascertained.

All values other than specified should be treated as error Cause No 41

19.7 Unsolicited result codes

Verbose result code	Numeric (V0 set)	Description
+CALA: < time string>,<index>	As verbose	Alarm notification
+CBM: <length><pdu> (PDU) or +CBM:<sn>,<mid>,<dcs>,<page>,<pages>... (Text mode)	As verbose	Cell Broadcast Message directly displayed
+CBMI: "BM",<index>	As verbose	Cell Broadcast Message stored in mem at location <index>
+CCCM : <ccm>	As verbose	Current Call Meter value
+CCED: <values>	As verbose (specific)	Cell Environment Description indication
+CCWA :<number>,<type>, <class> [,<alpha>]	As verbose	Call Waiting number
+CDS: <fo>, <mr>... (text mode) or +CDS: <length>,... (PDU)	As verbose	SMS status report after sending a SMS
+CDSI: <mem>,<index>	As verbose	Incoming SMS Status Report after sending a SMS, stored in <mem> ("SR") at location <index>
+CKEV: <keynb>	As verbose	Key press or release
+CLIP : <number>, <type> [, ,<alpha>]	As verbose	Incoming Call Presentation
+CMT: <oa>... (text mode) or +CMT: [<alpha>,...] (PDU)	As verbose	Incoming message directly displayed
+CMTI: <mem>,<index>	as verbose	Incoming message stored in <mem> ("SM") at location <index>
+CREG :<mode>,<stat>[,<lac>,<ci>]	As verbose	Network registration indication
+CRING : <type>	As verbose	Incoming call type (VOICE, FAX ...)
+CSQ: <RxLev>,<99>	As verbose	Automatic RxLev indication with AT+CCED=1,8 command
+CSSU: <code2>[<number>,<type>]	As verbose	Supplementary service notification during a call

29th September 2004

Verbose result code	Numeric (V0 set)	Description
+STIN: <ind>	As verbose (specific)	SIM Toolkit Indication
+WIND: <IndicationNb> [,<CallId>]	As verbose (specific)	Specific unsolicited indication (SIM Insert/Remove, End of init, Reset, Alerting, Call creation/release)
+WVMI: <Lineld>,<Status>	As verbose (specific)	Voice Mail Indicator notification (cf. +CPHS command)
+WDCI: <Lineld>,<Status>	As verbose (specific)	Diverted call indicator
RING	2	Incoming call signal from network
+WBCI	As Verbose (specific)	Battery charge indication
+CIEV	As Verbose (specific)	Indicator event reporting
+CUSD	As Verbose	Unstructured supplementary service data

19.8 Final result codes

Verbose result code	Numeric (V0 set)	Description
+CME ERROR: <err>	As verbose	Error from GSM 07.05 commands
+CMS ERROR: <err>	As verbose	Error from SMS commands (07.07)
BUSY	7	Busy signal detected
ERROR	4	Command not accepted
NO ANSWER	8	Connection completion timeout
NO CARRIER	3	Connection terminated
OK	0	Acknowledges correct execution of a command line
RING	2	Incoming call signal from network

29th September 2004

19.9 Intermediate result codes

Verbose result code	Numeric (V0 set)	Description
+COLP :<number>,<type>	as verbose	Outgoing Call Presentation
+CR : <type>	as verbose	Outgoing Call report control
+ILRR: <rate>	as verbose	Local TA-TE data rate
CONNECT 300	10	Data connection at 300 bauds
CONNECT 1200	11	Data connection at 1200 bauds
CONNECT 1200/75	12	Data connection at 1200/75 bauds
CONNECT 2400	13	Data connection at 2400 bauds
CONNECT 4800	14	Data connection at 4800 bauds
CONNECT 9600	15	Data connection at 9600 bauds
CONNECT 14400	16	Data connection at 14400 bauds
+CSSI: <code1>[,<index>]	As verbose	Supplementary service notification during a call setup

19.10 Parameters storage

Command	Parameters storage mode				Default values
	AT&W (E2P)	Command (E2P)	AT+CSAS (SIM, E2P)	AT&F (SIM, E2P)	

General commands					
Command	AT&W (E2P)	Command (E2P)	AT+CSAS (SIM, E2P)	AT&F (SIM, E2P)	Default values
+CMEE	X			X	0
+CRSL		X		X	6
+CSCS	X			X	"PCCP437"
+WPCS	X			X	"TRANSPARENT"

29th September 2004

Parameters storage mode					
Command	AT&W (E2P)	Command (E2P)	AT+CSAS (SIM, E2P)	AT&F (SIM, E2P)	Default values
Call Control commands					
%D		X		X	0
ATSO	X			X	0 (no auto-answer)
+CICB	X			X	2 (speech)
+CSNS	X			X	0 (voice)
+ECHO		X		X	For Wismo 2 and 3 ,1,0,3,10,7 (Algo ID 1) ,3,30,8000,256 (Algo ID 3) For Wismo 5: ,3,30,8000,256 (Algo ID 3)
+SIDET	X			X	1,1
+SPEAKER	X			X	0 (Spk 1 & Mic 1)
+VGR	X			X	64 (speaker 1) 32 (speaker 2)
+VGT	X			X	64 (mic 1 & ctrl 1) 0 (others)

Network Service commands					
+COPS	X	X		X	0,2
+CREG	X			X	0

Phonebook commands					
+CSVM		X		X	0
+WAIP	X			X	0

Parameters storage mode					
Command	AT&W (E2P)	Command (E2P)	AT+CSAS (SIM, E2P)	AT&F (SIM, E2P)	Default values

SMS commands					
+CNMI			X	X	0,1,0,0,0
+CMGF	X			X	1 (text)

29th September 2004

Parameters storage mode					
Command	AT&W (E2P)	Command (E2P)	AT+CSAS (SIM, E2P)	AT&F (SIM, E2P)	Default values
+CSCA			X		SIM dependant (phase 2)
+CSDH	X			X	0
+CSMP			X	X	1,167,0,0
+CSMS		X			0
+WUSS		X		X	0
+CMMS					0

Supplementary Services commands					
+CCUG		X			0,0,0
+CCWA	X			X	0
+CLIP	X			X	0
+COLP	X			X	0
+CSSN	X			X	0,0
+CUSD		X		X	0

Data commands					
%C	X			X	0
\N	X			X	0
+CBST	X			X	0,0,1
+CR	X			X	0
+CRC	X			X	0
+CRLP	X			X	61,61,48,6,1
+DOPT	X			X	1,1
+DS	X			X	3,0,4096,20
+DR	X			X	0
+ILRR	X			X	0

29th September 2004

Parameters storage mode					
Command	AT&W (E2P)	Command (E2P)	AT+CSAS (SIM, E2P)	AT&F (SIM, E2P)	Default values

Fax Class 2 commands					
+FBOR	X			X	0
+FCQ	X			X	0
+FCR	X			X	1
+FDCC,+FDIS	X			X	0,5,0,0,2,0,0,0,0
+FPHCTO	X			X	30

V24 - V25 commands					
&C	X				1
&D	X				2
&S	X				1
E	X				1
Q	X			X	0
V	X			X	1
+ICF	X				3,4
+IFC	X				2,2
+IPR	X				115200
+WMUX	X			X	0

29th September 2004

Specific commands					
+ADC		X		X	0
+CMER	X			X	,0,,0
+CPHS		X		X	1,0 for VMI 2,0 for MBN
+WBCM		X		X	0,0,4200,3300,100,5000,0
+WBHV		X		X	0,0 1,0
+WBM		X			0,0 for SPI bus 0,4 for I2C Soft bus
+WCDM		X		X	0,0
+WDR		X			0,1 for P51xx and Q31xx 2,1 (according to voice CODEC capabilities) for Q24xx
+WIND		X		X	0
+WIOM		X			1023,0 (for Q2xxx and P3xxx) 0,0 (for Q31 and P51 modules)
+WRIM		X		X	0
+WRIM		X		X	0
+WSVG		X		X	0
+WVR		X			5,0

29th September 2004

Parameters storage mode					
Command	AT&W (E2P)	Command (E2P)	AT+CSAS (SIM, E2P)	AT&F (SIM, E2P)	Default values

SIM Toolkit commands					
+STSF		X			0,"1F6BFFF1F",3,0

GPRS commands					
+CGAUTO	X			X	3
+CGCLASS		X			"B"
+CGDCONT		x			
+CGEREP	X			X	0
+CGREG	X			X	0
+CGSMS		X			1
+WGPRS		X			0,1 1,0 3,0 5,0 6,0

19.11 GSM sequences list

In accordance with **GSM 02.30**, the product supports the following GSM sequences, which can be used through the ATD and the +CKPD commands.

19.11.1 Security

**04*OLDPIN*NEWPIN*NEWPIN#	Change PIN code
**042*OLDPIN2*NEWPIN2*NEWPIN2#	Change PIN2 code
**05*PUK*NEWPIN*NEWPIN#	Unlock PIN code
**052*PUK2*NEWPIN2*NEWPIN2#	Unlock PIN2 code
*#06#	Show the IMEI number

29th September 2004

19.11.2 Call forwarding

*SC# <i>or</i> *SC**BS#	Activate
**SC*PhoneNumber# <i>or</i> **SC*PhoneNumber*BS# <i>or</i> **SC*PhoneNumber*[BS]*T# <i>or</i> *SC*PhoneNumber# <i>or</i> *SC*PhoneNumber*BS# <i>or</i> *SC*PhoneNumber*[BS]*T#	Register and activate
*#SC# <i>or</i> *#SC**BS#	Check status
#SC# <i>or</i> #SC**BS#	Deactivate
##SC# <i>or</i> ##SC**BS#	Unregistered and deactivate

The Service codes (SC) are:

002	all call forwarding
004	all conditional call forwarding
21	call forwarding unconditional
61	call forwarding on no answer
62	call forwarding on not reachable
67	call busy

29th September 2004

The Network service codes (BS) are:

No code	All tele and bearer services
10	All teleservices
11	Telephony
12	All data teleservices
13	Fax services
16	Short Message Services
17	Voice Group Call Service
18	Voice Broadcast Service
19	All teleservices except SMS
20	All bearer services
21	All asynchronous services
22	All synchronous services
24	All data circuit synchronous
25	All data circuit asynchronous

The no reply condition timer (T), is only used for SC = 002, 004 or 61.

19.11.3 Call barring

*SC*Password# or *SC*Password*BS#	Activate
*#SC# or *#SC**BS#	Check status
#SC*Password# or #SC*Password*BS#	Deactivate
**03*330*OLDPWD*NEWPWD*NEWPWD#	Change password for call barring
03OLDPWD*NEWPWD*NEWPWD#	
*03*330*OLDPWD*NEWPWD*NEWPWD#	
*03**OLDPWD*NEWPWD*NEWPWD#	

The Service codes (SC) are the followings:

33	call barring of outgoing call
330	all barring service (only for deactivation)
331	call barring of outgoing international call
332	call barring of outgoing international calls except to HPLMN
333	all outgoing barring service (only for deactivation)
35	call barring of incoming calls
351	call barring of incoming calls if roaming
353	all incoming barring service (only for deactivation)

29th September 2004

The Network service codes (BS) are the same as these of the call forwarding sequences.

19.11.4 Call waiting

*43*BS#	Activate
*#43*BS#	Check status
#43*BS#	Deactivate

19.11.5 Number presentation

*#30#	CLIP check status
*#31#	CLIR check status
*31#PhoneNumber	Suppress CLIR for a voice call
#31#PhoneNumber	Invoke CLIR for a voice call
*#76#	COLP check status

29th September 2004

19.12 Operator names

This list is extracted from the SE.13 (May 11th 2004 edition) and NAPRD10.2.6.2 documents. Country initials may vary for the same MCC (Mobile Country Code), without any impact.

Country Initials	MCC	MNC	Preferred Presentation of Country Initials and Mobile Network Name	Abbreviated Mobile Network Name
GRC	202	1	GR COSMOTE	C-OTE
GRC	202	5	vodafone GR	voda GR
GRC	202	9	GR Q-TELECOM	Q-TELCOM
GRC	202	10	TIM GR	TIM
NLD	204	4	vodafone NL	voda NL
NLD	204	8	NL KPN	NL KPN
NLD	204	12	NL Telfort	NL Tlft
NLD	204	16	T-Mobile NL	TMO NL
NLD	204	20	Orange NL	Orange
BEL	206	1	BEL PROXIMUS	PROXI
BEL	206	10	B mobistar	mobi*
BEL	206	20	BASE	BASE
FRA	208	1	Orange F	Orange
FRA	208	3	Orange	Orange
FRA	208	10	F SFR	SFR
FRA	208	20	F - BOUYGUES TELECOM	BYTEL
AND	213	3	STA-MOBILAND	M-AND
ESP	214	1	vodafone ES	voda ES
ESP	214	3	E AMENA	AMENA
ESP	214	7	MOVISTAR	MSTAR
HUN	216	1	H PANNON GSM	PANNON
HUN	216	30	T-Mobile H	TMO H
HUN	216	70	vodafone HU	voda HU
BIH	218	3	BA-ERONET	ERONET
BIH	218	5	MOBI'S	MOBI'S
BIH	218	90	BH GSMBIH	GSMBIH
HRV	219	1	HTmobile HR	HTmobile
HRV	219	10	HR VIP	VIP
SCG	220	1	YU MOBTEL	MOBTEL
SCG	220	2	ProMonte	ProMonte
SCG	220	3	YUG 03	SCGTS

29th September 2004

Country Initials	MCC	MNC	Preferred Presentation of Country Initials and Mobile Network Name	Abbreviated Mobile Network Name
SCG	220	4	MONET	MONET
ITA	222	1	I TIM	TIM
ITA	222	10	vodafone IT	voda IT
ITA	222	88	I WIND	I WIND
ITA	222	99	3 ITA	3 ITA
ROU	226	1	RO CONNEX	CONNEX
ROU	226	3	RO Cosmorom	Cosmorom
ROU	226	10	RO ORANGE	ORANGE
CHE	228	1	SWISS GSM	SWISS
CHE	228	2	sunrise	sunrise
CHE	228	3	orange CH	ORANGE
CZE	230	1	T-Mobile CZ	TMO CZ
CZE	230	2	EUROTEL - CZ	ET - CZ
CZE	230	3	OSKAR	OSKAR
SVK	231	1	Orange SK	Orange
SVK	231	2	EUROTEL-SK	ET-SK
AUT	232	1	A1	A1
AUT	232	3	T-Mobile A	TMO A
AUT	232	5	one	one
AUT	232	7	A tele.ring	telering
AUT	232	10	3 AT	3 AT
GBR	234	10	O2 - UK	O2 -UK
GBR	234	15	vodafone UK	voda UK
GBR	234	20	3 UK	3 UK
GBR	234	30	T-Mobile UK	TMO UK
GBR	234	31	T-Mobile UK	TMO UK
GBR	234	32	T-Mobile UK	TMO UK
GBR	234	33	Orange	Orange
GBR	234	50	JT GSM	JT GSM
GBR	234	55	Cable & Wireless Guernsey	C&W
GBR	234	58	Manx Pronto	Pronto
DNK	238	1	TDC MOBIL	DK TDC
DNK	238	2	DK SONOFON	SONO
DNK	238	6	3 DK	3 DK
DNK	238	20	TELIA DK	TELIA
DNK	238	30	Orange	Orange
SWE	240	1	TELIA S	TELIA

29th September 2004

Country Initials	MCC	MNC	Preferred Presentation of Country Initials and Mobile Network Name	Abbreviated Mobile Network Name
SWE	240	2	3 SE	3 SE
SWE	240	4	SWEDEN	SWE
SWE	240	5	Sweden 3G	Sweden3G
SWE	240	7	S COMVIQ	IQ
SWE	240	8	vodafone SE	voda SE
SWE	240	10	SpringMobil SE	Spring
NOR	242	1	N Telenor	TELENOR
NOR	242	2	N NetCom GSM	N COM
FIN	244	3	FINNET	FINNET
FIN	244	5	FI elisa	elisa
FIN	244	12	FINNET	FINNET
FIN	244	14	FI AMT	FI AMT
FIN	244	91	FI SONERA	SONERA
LTU	246	1	OMNITEL LT	OMT
LTU	246	2	LT BITE GSM	BITE
LTU	246	3	TELE2	TELE2
LVA	247	1	LV LMT GSM	LMT GSM
LVA	247	2	LV TELE2	TELE2
EST	248	1	EE EMT GSM	EMT
EST	248	2	EE RLE	RLE
EST	248	3	TELE2	TELE2
RUS	250	1	MTS-RUS	MTS
RUS	250	2	MegaFon RUS	MegaFon
RUS	250	4	SIBCHALLENGE RUS	RUS_SCN
RUS	250	5	SCS RUS	SCS
RUS	250	7	RUS SMARTS	SMARTS
RUS	250	10	RUS DTC	DTC
RUS	250	11	ORENSOT	ORENSOT
RUS	250	12	RF FAR EAST	RF FEast
RUS	250	13	RUS Kuban-GSM	KUGSM
RUS	250	14	RUS Di-ex	Di-ex
RUS	250	15	RUS SMARTS	SMARTS
RUS	250	16	RUS16	NTC
RUS	250	17	RUS 17	ERMAK
RUS	250	19	RUS_BASHCELL	BASHCELL
RUS	250	20	RUS 20	MOTIV
RUS	250	28	Bee Line	Bee Line

29th September 2004

Country Initials	MCC	MNC	Preferred Presentation of Country Initials and Mobile Network Name	Abbreviated Mobile Network Name
RUS	250	39	Uraltel	RUS39
RUS	250	44	RUS North Caucasian GSM	NC-GSM
RUS	250	92	Primetefone RUS	Primtel
RUS	250	99	Bee Line	Bee Line
UKR	255	1	UA UMC	UMC
UKR	255	2	UKR-WellCOM	WellCOM
UKR	255	3	UA-KYIVSTAR	UA-KS
UKR	255	5	UA-GT	GT
BLR	257	1	BY VELCOM	VELCOM
BLR	257	2	MTS BY	MTS
MDA	259	1	MD VOXTEL	VOXTEL
MDA	259	2	MD MOLDCELL	MDCELL
POL	260	1	Plus GSM	PLUS
POL	260	2	Era	Era
POL	260	3	PL IDEA	IDEA
DEU	262	1	T-Mobile D	TMO D
DEU	262	2	Vodafone.de	voda DE
DEU	262	3	E-Plus	E-Plus
DEU	262	7	o2 - de	o2 - de
GIB	266	1	GIBTEL GSM	GIBTEL
PRT	268	1	vodafone P	voda P
PRT	268	3	P OPTIMUS	OPTIM
PRT	268	6	P TMN	TMN
LUX	270	1	L LUXGSM	LUXGSM
LUX	270	77	L TANGO	TANGO
LUX	270	99	L-VOX.mobile	VOX.LU
IRL	272	1	vodafone IE	voda IE
IRL	272	2	02 - IRL	02 -IRL
IRL	272	3	IRL - METEOR	METEOR
ISL	274	1	IS SIMINN	SIMINN
ISL	274	2	Og Vodafone	Vodafone
ISL	274	3	Og Vodafone	Vodafone
ISL	274	4	Viking	Viking
ALB	276	1	AMC - AL	A M C
ALB	276	2	vodafone AL	voda AL
MLT	278	1	vodafone MT	voda MT
MLT	278	21	go mobile	gomobile

29th September 2004

Country Initials	MCC	MNC	Preferred Presentation of Country Initials and Mobile Network Name	Abbreviated Mobile Network Name
CYP	280	1	CY CYTAGSM	CY-GSM
CYP	280	10	areeba	areeba
GEO	282	1	GEO-GEOCELL	GCELL
GEO	282	2	MAGTI-GSM-GEO	MAGTI
ARM	283	1	RA-ARMGSM	ARMMO1
ARM	283	4	RA 04	RA 04
BGR	284	1	M-TEL GSM BG	M-TEL
BGR	284	5	BG GLOBUL	GLOBUL
TUR	286	1	TR TURKCELL	TCELL
TUR	286	2	TR TELSIM	TELSIM
TUR	286	3	TR ARIA	ARIA
TUR	286	4	TR AYCELL	AYCELL
FRO	288	1	Føroya Tele	FT-GSM
FRO	288	2	KALL	KALL
GRL	290	1	TELE Greenland	TELE GRL
SVN	293	40	SI vodafone	SI voda
SVN	293	41	SI MOBITEL GSM	SI-GSM
SVN	293	70	SI VEGA 070	VEGA 070
MKD	294	1	MKD-MOBIMAK	MOBI-M
MKD	294	2	MKD COSMOFON	COSMOFON
LIE	295	1	FL GSM	FLGSM
LIE	295	2	Orange FL	OFL
LIE	295	5	FL1	FL1
LIE	295	77	LI TANGO	TANGO
CAN	302	370	Fido	Fido
CAN	302	720	Rogers AT&T Wireless	ROGERS
USA	310	20	Union Telephone	Union Tel
USA	310	26	T-Mobile	TMO
USA	310	30	Centennial Wireless	Centennial
USA	310	31	T-Mobile	TMO
USA	310	40	Cellular One	Cellular One
USA	310	50	DIGICEL	JAM DC
USA	310	70	Highland Cellular	Highland
USA	310	80	Corr Wireless	Corr
USA	310	100	Plateau Wireless	Plateau
USA	310	150	Cingular Wireless	Cingular
USA	310	160	T-Mobile	T-Mobile

29th September 2004

Country Initials	MCC	MNC	Preferred Presentation of Country Initials and Mobile Network Name	Abbreviated Mobile Network Name
USA	310	170	Cingular Wireless	Cingular
USA	310	180	West Central Wireless	West Central
USA	310	190	Alaska Wireless	Alaska Wireless
USA	310	200	T-Mobile	T-Mobile
USA	310	210	T-Mobile	T-Mobile
USA	310	220	T-Mobile	T-Mobile
USA	310	230	T-Mobile	T-Mobile
USA	310	240	T-Mobile	T-Mobile
USA	310	250	T-Mobile	T-Mobile
USA	310	260	T-Mobile	T-Mobile
USA	310	270	T-Mobile	T-Mobile
USA	310	310	T-Mobile	T-Mobile
USA	310	311	FARMERS	FARMERS
USA	310	320	USA - CellularOne	Cell
USA	310	340	WestLink Comm	WestLink
USA	310	350	Carolina Phone	Carolina
USA	310	380	AT&T Wireless	AT&T
USA	310	390	Yorkville Telephone	Yorkville
USA	310	410	Cingular Wireless	Cingular
USA	310	420	Cincinnati Bell Wireless	CBW
USA	310	450	Viaero Wireless	Viaero
USA	310	460	USA ONELINK	ONELINK
USA	310	490	SunCom	SunCom
USA	310	500	PSC Wireless	PSC
USA	310	530	West Virginia Wireless	WVW
USA	310	560	Cellular One DCS	Cell One
USA	310	580	T-Mobile	T-Mobile
USA	310	590	USA - Extended Area	ROAMING
USA	310	610	Epic Touch	EpicTouch
USA	310	630	AmeriLink PCS	AmeriLink
USA	310	640	Einstein PCS	Einstein
USA	310	660	T-Mobile	T-Mobile
USA	310	670	Wireless 2000 PCS	W 2000 PCS
USA	310	680	NPI Wireless	NPI
USA	310	690	Immix Wireless	IMMIX
USA	310	740	Telemetrix	Telemetrix
USA	310	760	PTSI	PTSI

29th September 2004

Country Initials	MCC	MNC	Preferred Presentation of Country Initials and Mobile Network Name	Abbreviated Mobile Network Name
USA	310	770	IWS	IWS
USA	310	780	AirLink PCS	AirLink
USA	310	790	Pinpoint	Pinpoint
USA	310	800	T-Mobile	T-Mobile
USA	310	870	US	PACE
USA	310	880	USAACSI	ACSIAC
USA	310	910	USAFC	FCSI
USA	310	940	Digital Cellular	DCT
USA	310	950	USA XIT Cellular	XIT
USA	310	980	AT&T Wireless	AT&T
USA	311	0	Wilkes USA	WILKES
USA	311	1	Wilkes USA	WILKES
USA	311	5	Wilkes USA	WILKES
USA	311	30	Indigo	Indigo
USA	311	70	USAEC	EASTER
USA	311	80	Pine Cellular	PINECell
USA	311	110	High Plains	HPW
USA	311	140	Sprocket	Sprocket
USA	311	160	EMW	EMW
USA	311	170	PetroCom	PetroCom
USA	311	190	USAC1ECI	C1ECI
USA	332	11	Blue Sky	Blue Sky
MEX	334	3	MX MOVISTAR GSM	MOVISTAR
MEX	334	20	Telcel GSM	TELCEL
JAM	338	5	JM DIGICEL	DIGICEL
JAM	338	180	C&W	C&W
FRA	340	1	F-Orange	Orange
GLP	340	8	AMIGO	AMIGO
FRA	340	20	BOUYGTEL-C	BOUYG-C
BRB	342	50	JM Digicel	Digicel
BRB	342	600	C&W	C&W
BRB	342	810	AT&T Wireless	AT&T
ATG	344	30	APUA-PCS ANTIGUA	APUA-PCS
ATG	344	920	C&W	C&W
ATG	344	930	AT&T Wireless	AT&T
CYM	346	140	C&W	C&W
VGB	348	570	CCT Boatphone	CCTBVI

29th September 2004

Country Initials	MCC	MNC	Preferred Presentation of Country Initials and Mobile Network Name	Abbreviated Mobile Network Name
BMU	350	2	BTC MOBILITY LTD.	MOBILITY
BMU	350	10	AT&T Wireless	AT&T
GRD	352	30	AT&T Wireless	AT&T
GRD	352	50	Digicel	DIGICEL
GND	352	110	C&W	C&W
GRD	352	130	TWTCGN	TWTCGN
MS	354	860	C&W	C&W
KNA	356	110	C&W	C&W
LCA	358	30	AT&T Wireless	AT&T
SLU	358	110	C&W	C&W
VCT	360	10	AT&T Wireless	AT&T
VCT	360	110	C&W	C&W
ANT	362	51	Telcell GSM	Telcell
ANT	362	69	ANT CURACAO TELECOM GSM	CT GSM
ANT	362	91	UTS Wireless Curacao N.V.	UTS
ABW	363	1	SETAR GSM	SETARGSM
BHS	364	39	BaTelCell	BaTelCel
AIA	365	840	C&W	C&W
DMA	366	20	AT&T Wireless	AT&T
DMA	366	110	C&W	C&W
CUB	368	1	CU/C_COM	C_COM
DO	370	1	ORANGE	ORANGE
TTO	374	12	TSTT	TSTT
TCA	376	350	C&W	C&W
AZE	400	1	AZE - AZERCELL GSM	ACELL
AZE	400	2	BAKCELL GSM 2000	BKCELL
KAZ	401	1	KZ K-MOBILE	K-MOBILE
KAZ	401	2	KZ KCELL	KCELL
BTN	402	11	BT B-Mobile	B-Mobile
IND	404	1	Hutch	Hutch
IND	404	2	AirTel	AirTel
IND	404	3	AirTel	AirTel
IND	404	4	IDEA	IDEA
IND	404	5	Hutch	Hutch
IND	404	7	IDEA	IDEA
IND	404	10	AirTel	AirTel
IND	404	11	Hutch	Hutch

29th September 2004

Country Initials	MCC	MNC	Preferred Presentation of Country Initials and Mobile Network Name	Abbreviated Mobile Network Name
IND	404	12	INDEH	ESCOTEL
IND	404	13	Hutch	Hutch
IND	404	14	INA SPICE	SPICE
IND	404	15	Hutch	Hutch
IND	404	19	INDEK	ESCOTEL
IND	404	20	Orange	Orange
IND	404	21	BPL MOBILE	BPL MOBILE
IND	404	22	IDEA	IDEA
IND	404	24	IDEA	IDEA
IND	404	27	BPL MOBILE	BPL MOBILE
IND	404	30	Hutch	Hutch
IND	404	31	AirTel	AirTel
IND	404	34	BSNL MOBILE	CellOne
IND	404	38	BSNL MOBILE	CellOne
IND	404	40	IND AIRTEL	AIRTEL
IND	404	41	INA RPG	RPG
IND	404	42	INA AIRCEL	AIRCEL
IND	404	43	BPL MOBILE	BPL MOB
IND	404	44	INA SPICE	SPICE
IND	404	45	AirTel	AirTel
IND	404	46	BPL MOBILE	BPL MOB
IND	404	49	AirTel	AirTel
IND	404	51	BSNL MOBILE	CellOne
IND	404	53	BSNL MOBILE	CellOne
IND	404	54	BSNL MOBILE	CellOne
IND	404	55	BSNL MOBILE	CellOne
IND	404	56	INDEU	ESCOTEL
IND	404	57	BSNL MOBILE	CellOne
IND	404	58	BSNL MOBILE	CellOne
IND	404	59	BSNL MOBILE	CellOne
IND	404	60	Hutch	Hutch
IND	404	62	BSNL MOBILE	CellOne
IND	404	64	BSNL MOBILE	CellOne
IND	404	66	BSNL MOBILE	CellOne
IND	404	68	IN-DOLPHIN	DOLPHIN
IND	404	69	IN-DOLPHIN	DOLPHIN
IND	404	70	INDH1	Oasis

29th September 2004

Country Initials	MCC	MNC	Preferred Presentation of Country Initials and Mobile Network Name	Abbreviated Mobile Network Name
IND	404	71	BSNL MOBILE	CellOne
IND	404	72	BSNL MOBILE	CellOne
IND	404	73	BSNL MOBILE	CellOne
IND	404	74	BSNL MOBILE	CellOne
IND	404	75	BSNL MOBILE	CellOne
IND	404	76	BSNL MOBILE	CellOne
IND	404	77	BSNL MOBILE	CellOne
IND	404	78	IDEA	IDEA
IND	404	79	BSNL MOBILE	CellOne
IND	404	80	BSNL MOBILE	CellOne
IND	404	81	BSNL MOBILE	CellOne
IND	404	84	Hutch	Hutch
IND	404	86	Hutch	Hutch
IND	404	88	Hutch	Hutch
IND	404	90	AirTel	AirTel
IND	404	92	AirTel	AirTel
IND	404	93	AirTel	AirTel
IND	404	94	AirTel	AirTel
IND	404	95	AirTel	AirTel
IND	404	96	AirTel	AirTel
IND	404	97	AirTel	AirTel
IND	404	98	AirTel	AirTel
PAK	410	1	PK MK	PMCL
PAK	410	3	PK-UFONE	UFONE
PAK	410	4	PAK - PL	PAKTEL
AFG	412	1	AF AWCC	AWCC
AFG	412	20	AF TDCA	TDCA
SRI	413	1	Mobitel	MOBITEL
SRI	413	2	SRI DIALOG	DIALOG
SRI	413	3	SRI - CELLTEL	CELLTEL
MMR	414	1	MM 900	MPTGSM
LBN	415	1	RL Cellis	CLLIS
LBN	415	3	RL LibanCell	LibCL
JOR	416	1	Fastlink	FSTLNK
JOR	416	77	JO MobCom	MobCom
SYR	417	1	SYRIATEL	SYRIATEL
SYR	417	2	94 SYRIA	94 SYRIA

29th September 2004

Country Initials	MCC	MNC	Preferred Presentation of Country Initials and Mobile Network Name	Abbreviated Mobile Network Name
SYR	417	9	SYR MOBILE SYR	MOBILE
IRQ	418	0	ASIACELL	ASIACELL
IRQ	418	2	SanaTel	SanaTel
IRQ	418	5	ASIACELL	ASIACELL
IRQ	418	8	SanaTel	SanaTel
IRQ	418	20	Atheer Iraq	ATHEER
IRQ	418	30	IRAQNA	IRAQNA
KWT	419	2	KT MTCNet	MTC
KWT	419	3	KT WATANIYA	WATANIYA
KSA	420	1	ALJAWAL	KSA
YEM	421	1	SabaFon	SABAFON
YEM	421	2	SPACETEL	SPACETEL
OMN	422	2	OMAN MOBILE	OMAN
UAE	424	2	UAE ETISALAT	ETSLT
ISR	425	1	IL ORANGE	ORANGE
ISR	425	2	IL Cellcom	Cellcom
ISR	425	5	JAWWAL-PALESTINE	JAWWAL
BHR	426	1	BATELCO	BATELCO
BHR	426	2	MTC VODAFONE BH	MTC-VFBH
QAT	427	1	QAT QATARNET	Q-NET
MNG	428	99	MN MobiCom	MobiCom
IRN	432	11	IR-TCI	432 11
IRN	432	14	IR KISH	KIFZO
IRN	432	19	IR MTCE	MTCE
UZB	434	2	UZMACOM	UZMGSM
UZB	434	4	UZB DAEWOO-GSM	DW-GSM
UZB	434	5	UZB CSOCOM GSM	COSCOM
UZB	434	7	UZB-UZD	UZDGSM
TJK	436	1	Somoncom	Somoncom
TJK	436	2	Indigo-T	INDIGO
TJK	436	3	TJK MLT	MLT
TJK	436	4	Babilon-M	Babilon
TJK	436	5	TJT - Tajik Tel	TajikTel
KGZ	437	1	BITEL KGZ	BITEL
JPN	440	10	JP DoCoMo	DoCoMo
JPN	440	20	Vodafone JP	Voda JP
KOR	450	2	KR KTF	KTF

29th September 2004

Country Initials	MCC	MNC	Preferred Presentation of Country Initials and Mobile Network Name	Abbreviated Mobile Network Name
KOR	450	8	KR KTF	KTF
VNM	452	1	VN MOBIFONE	VMS
VNM	452	2	VN VINAPHONE	GPC
VNM	452	4	VNM and VIETTEL	VIETTEL
HKG	454	0	CSL	CSL
HKG	454	3	3 HK	3
HKG	454	4	HK ORANGE	ORANGE
HKG	454	6	SmarTone	SmarTone
HKG	454	10	HK NEW WORLD	NWPCS
HKG	454	12	HK PEOPLES	PEOPLES
HKG	454	15	SmarTone 3G	SMC 3G
HKG	454	16	HK SUNDAY	SUNDAY
MAC	455	0	Macau SMC	SmarTone
MAC	455	1	MAC-CTMGSM	CTMGSM
MAC	455	3	Hutchison MAC	HT Macau
KHM	456	1	MOBITEL - KHM	MT-KHM
KHM	456	2	KHM>Hello GSM	KHM-SM
KHM	456	18	CAMBODIA SHINAWATRA	CAMSHIN
LAO	457	1	LAO GSM	LAO GSM
LAO	457	2	ETL MOBILE NETWORK	ETLMNW
LAO	457	3	45703	LATMOBIL
LAO	457	8	TANGO LAO	TANGO
CHN	460	0	CHINA MOBILE	CMCC
CHN	460	1	CHN-CUGSM	CU-GSM
TWN	466	1	Far EasTone	FET
TWN	466	6	TWN Tuntex GSM 1800	TUNTEX
TWN	466	68	ACeS	ACeS
TWN	466	88	KGT-Online	KGT
TWN	466	89	T3G	T3G
TWN	466	92	Chunghwa	CHT
TWN	466	93	TWN MOBITAI	TW MOB
TWN	466	97	TWN GSM 1800	TCC
TWN	466	99	TransAsia	TransAsi
PRK	467	3	KP SUN	SUNNET
BGD	470	1	BGD-GP	GP
BGD	470	2	BGD AKTEL	AKTEL
BGD	470	3	BD ShebaWorld	SHEBA

29th September 2004

Country Initials	MCC	MNC	Preferred Presentation of Country Initials and Mobile Network Name	Abbreviated Mobile Network Name
MDV	472	1	MV DHIMOBILE	D-MOBILE
MYS	502	12	MY MAXIS	MY MAXIS
MYS	502	16	DiGi	DiGi
MYS	502	19	MY CELCOM	CELCOM
AUS	505	1	Telstra Mobile	Telstra
AUS	505	2	YES OPTUS	Optus
AUS	505	3	vodafone AU	voda AU
AUS	505	6	3 AUS	3 AUS
IDN	510	0	ACeS	ACeS
IDN	510	1	IND INDOSAT	INDOSAT
IDN	510	8	LIPPO TEL	LIPPOTEL
IDN	510	10	IND TELKOMSEL	T-SEL
IDN	510	11	IND - Excelcom	proXL
IDN	510	21	IND INDOSAT	INDOSAT
TLS	514	2	TLS-TT	TT
PHL	515	1	ISLACOM	ISLACOM
PHL	515	2	Globe Telecom-PH	GLOBE
PHL	515	3	SMART	SMART
PHL	515	5	PH Sun Cellular	SUN
PHL	515	11	ACeS	ACeS
THA	520	1	TH GSM	TH GSM
THA	520	15	TH ACT 1900	ACT-1900
THA	520	18	TH-DTAC	DTAC
THA	520	20	ACeS	ACeS
THA	520	23	TH GSM 1800	GSM 1800
THA	520	99	Orange Th	Orange
SGP	525	1	SingTel	SingTel
SGP	525	2	SingTel-G18	SingTel
SGP	525	3	SGP-M1-3GSM	M1-3GSM
SGP	525	5	STARHUB-SGP	STARHUB
NZL	530	1	vodafone NZ	voda NZ
PNG	537	1	PNGBMobile	BMobile
TON	539	1	U-CALL	U-CALL
VUT	541	1	VUT SMILE	SMILE
FJI	542	1	FJ VODAFONE	VODAFONE
AS	544	11	Blue Sky	Blue Sky
KIR	545	9	KL-Frigate	KI-FRIG

29th September 2004

Country Initials	MCC	MNC	Preferred Presentation of Country Initials and Mobile Network Name	Abbreviated Mobile Network Name
NCL	546	1	NCL MOBILIS	MOBNCL
FRA	547	20	F-VINI	VINI
COK	548	1	CK KOKANET	KOKANET
FSM	550	1	FSM Telecom	FSMTC
EGY	602	1	EGY MobiNiL	MobiNiL
EGY	602	2	vodafone EG	voda EG
DZA	603	1	ALGERIAN MOBILE NETWORK	AMN
DZA	603	2	Djezzy	Djezzy
DZA	603	3	DZA-WTA	WTA
MOR	604	0	MOR MEDITEL	MEDITEL
MOR	604	1	MOR IAM	IAM
TUN	605	2	TUNISIE TELECOM	TUNTEL
TUN	605	3	TUNISIANA	TUNSIANA
GMB	607	1	GAMCEL	GAMCEL
GMB	607	2	AFRICELL	AFRICELL
SEN	608	1	SN ALIZE	ALIZE
SEN	608	2	SN-SENTEL SG	SENTEL
MRT	609	1	MR MATTEL	MATTEL
MRT	609	10	MAURITEL	MAURITEL
MLI	610	1	MALITEL ML	MALITEL
MLI	610	2	IKATEL ML	IKATEL
GIN	611	2	GN LAGUI	LAGUI
CIV	612	3	Orange CI	Orange
CIV	612	5	TELECEL-CI	TELCEL
BFA	613	2	BF Celtel	celtel
NER	614	2	NE CELTEL	NECELTEL
NER	614	3	NE TELECEL	TELECEL
TGO	615	1	TG-TOGO CELL	TGCELL
BEN	616	2	TELECEL BENIN	TLCL-BEN
BEN	616	3	BJ BENINCELL	BENCELL
BEN	616	4	BELL BENIN COMMUNICATION	BBCOM
MRU	617	1	CELLPLUS-MRU	CELL +
MRU	617	10	EMTEL-MRU	EMTEL
LBR	618	1	LBR Lonestar Cell	LoneStar
LBR	618	2	LIBERCELL	LIBERCEL
SLE	619	1	CELTEL SL	CELTEL
SLE	619	2	MILLICOM SL	MILLICOM

29th September 2004

Country Initials	MCC	MNC	Preferred Presentation of Country Initials and Mobile Network Name	Abbreviated Mobile Network Name
GHA	620	1	GH SPACEFON	SPACE
GHA	620	2	GH ONEtouch	ONEtouch
GHA	620	3	GH-MOBITEL	mobitel
NGA	621	20	ECONET NG	ECONET
NGA	621	30	MTN - NG	MTN-NG
NGA	621	40	NG Mtel	Mtel
NGA	621	50	Glo NG	glo
TCD	622	1	CELTEL TCD	CELTEL
TCD	622	2	TD LIBERTIS	LIBERTIS
CMR	624	1	MTN CAM	62401
CMR	624	2	Orange CAM	Orange
CPV	625	1	CPV MOVEL	CMOVEL
STP	626	1	STP CSTmovel	CSTmovel
GNQ	627	1	GNQ01	GETESA
GAB	628	1	LIBERTIS	LIBERTIS
GAB	628	2	GAB TELECEL	TELECEL
GAB	628	3	CELTEL GA	CELTEL
COG	629	1	CELTEL CD	CELTEL
COG	629	10	COG LIBERTIS	LIBERTIS
COD	630	1	VODACOM CD	VODACOM
COD	630	2	CELTEL RC	CELTEL
COD	630	4	CELLCO GSM	CELLCO
COD	630	89	CD OASIS	OASIS
AGO	631	2	UNITEL	UNITEL
SEZ	633	1	SEYCEL	633-01
SEZ	633	10	SEZ AIRTEL	AIRTEL
SUD	634	1	MobiTel SDN	MobiTel
RWA	635	10	R-CELL	RCELL
ETH	636	1	ETH-MTN	ET-MTN
SOM	637	1	SOMTELESOM	TELESOM
SOM	637	82	Telsom Mobile	telsom
DJI	638	1	DJ EVATIS	EVATIS
KEN	639	2	Safaricom	SAF-COM
KEN	639	3	YES!	YES!
TZA	640	2	MOBITEL - TZ	MOBITEL
TZA	640	3	ZANTEL-TZ	ZANTEL
TZA	640	4	VodaCom	VodaCom

29th September 2004

Country Initials	MCC	MNC	Preferred Presentation of Country Initials and Mobile Network Name	Abbreviated Mobile Network Name
TZA	640	5	celtel	celtel
UGA	641	1	UG CelTel	CELTEL
UGA	641	10	MTN-UGANDA	MTN-UG
UGA	641	11	mango	mango
BDI	642	1	Spacetel BI	SPACETEL
BDI	642	2	BUSAFA	SAFARIS
MOZ	643	1	MOZ - mCel	mCel
MOZ	643	4	VodaCom-MZ	VodaCom
ZMB	645	1	ZM CELTEL	CELTEL
ZMB	645	2	TELECEL ZM	TELECEL
MDG	646	1	MG Madacom	Madacom
MDG	646	2	MG ANTARIS	ANTARIS
REU	647	0	Orange re	Orange
REU	647	2	F-OMT	OMT
FRA	647	10	SFR REUNION	SFR RU
ZWE	648	1	ZW NET*ONE	NETONE
ZWE	648	3	TELECEL ZW	TELECEL
ZWE	648	4	ZW ECONET	ECONET
NAM	649	1	MTC NAMIBIA	MTCNAM
MWI	650	1	MW CP 900	CP 900
MWI	650	10	CELTEL MW	CELTEL
LSO	651	1	VCL COMMS	VCLCOM
LSO	651	2	LS-ECONET-EZI-CEL	EZI-CEL
BWA	652	1	BW MASCOM	MASCOM
BWA	652	2	Orange	Orange
SWZ	653	10	Swazi-MTN	SwaziMTN
COM	654	1	HURI	HURI
ZAF	655	1	VodaCom-SA	VODA
ZAF	655	7	Cell C	Cell C
ZAF	655	10	MTN-SA	MTN
BLZ	702	67	BTL	BTL
BLZ	702	68	INTELCO	INTELCO
GTM	704	2	Comcel_GSM	COMCEL
GTM	704	3	MoviStar	MoviStar
ESV	706	1	ESV PERSONAL	PERSONAL
SLV	706	2	Digicel	DIGICEL
SLV	706	3	TELEMOVIL	TM

29th September 2004

Country Initials	MCC	MNC	Preferred Presentation of Country Initials and Mobile Network Name	Abbreviated Mobile Network Name
SLV	706	4	MoviStar	MoviStar
ESV	706	10	ESV PERSONAL	PERSONAL
HND	708	1	MEGATEL	HNDMGT
HND	708	2	CELTELHND	CELTEL
NIC	710	21	ENITEL	ENITEL
NIC	710	73	SERCOM	SERCOM
CRI	712	1	I.C.E.	I.C.E.
PAN	714	1	PANCW	PANCW
PE	716	10	TIM PERU	TIM
ARG	722	7	UNIFON	UNIFON
ARG	722	34	PERSONAL	AR TP
ARG	722	35	PORT-HABLE	P-HABLE
ARG	722	310	ARG CTI Movil	CTIMovil
BRA	724	2	TIM BRASIL	TIM
BRA	724	3	TIM BRASIL	TIM
BRA	724	4	TIM BRASIL	TIM
BRA	724	5	Claro	Claro
BRA	724	15	BRA SCTL	SCTL
BRA	724	16	BRA BrTCelular	BrTCel
BRA	724	31	Oi	Oi
CHL	730	1	ENTEL PCS	ENTEL PCS
CHL	730	2	TELEFONICA	TMOVIL
CHL	730	10	ENTEL PCS	ENTEL PCS
COL	732	101	COLOMBIA - COMCEL S.A	COMCEL
COL	732	111	COL MOVIL	COL MOVIL
VEN	734	1	VZ INFO	INFONT
VEN	734	2	DIGITEL TIM	DIGITEL
BOL	736	1	NUEVATEL	VIVA
BOL	736	2	EMOVIL	BOMOV
GUY	738	1	GUY TW	TWTGUY
ECU	740	1	PORTA GSM	PORTAGSM
PGY	744	1	HOLA PARAGUAY	VOX
PGY	744	2	PGY Porthable	Porth
PRY	744	4	Telecel GSM	Telecel
SUR	746	2	SR.TELESUR.GSM	TeleG
	901	5	Thuraya	Thuraya

29th September 2004

19.13 Data / Commands multiplexing protocol

19.13.1 Introduction

The Wavecom multiplexing protocol operates between a DCE (Data Communication Equipment: the product) and a DTE (Data Terminal Equipment). It allows a double session over a serial link interface : one for AT commands and one for DATA communications.

AT+WMUX=1 activates the Multiplexing Mode. With this mode, AT commands and DATA are encapsulated into packets. The header of these packets allows to recognize whether it is a DATA packet or an AT command packet. AT+WMUX=0 deactivates the Multiplexing Mode and gets the product back to the default mode.

This appendix presents how the multiplexing mode handles the DATA and the AT commands flow. It also describes the format of DATA packets and AT command packets.

19.13.2 AT command packets

An AT command is encapsulated into a packet with a header which allows to separate it from DATA packets. This packet is formed by a header (3 bytes), the AT command itself and a checksum (1 byte) :

B7	B6	B5	B4	B3	B2	B1	B0
Start pattern → 0xAA							
AT command length LSB							
AT command pattern → 0x1D					AT command length MSB		
AT command							
Checksum							

The 3 bytes of the header are:

- ➔ the first byte (0xAA) is used to identify the packet,
- ➔ the second byte represents the 8 LSB (Low Significant Bits) bits of the length of the AT command,
- ➔ the third byte is made of 2 parts :
 - the 3 LSB bits are the 3 MSB (Most Significant Bits) bits of the length of the AT command,
 - the 5 MSB bits (0x1D which equals to 0xE8 with the 3 bits offset) are used to identify an AT command.

The maximum length of an AT command could be 2047 bytes which is greater than all the existing AT commands.

The checksum is the addition (modulo 256) of all the transmitted bytes (header bytes and AT command bytes).

29th September 2004

19.13.3 Data packets

Like for AT commands, DATA are encapsulated into packets. These packets are composed of a header (3 bytes), the data bytes and the checksum (1 byte) :

B7	B6	B5	B4	B3	B2	B1	B0
Start pattern → 0xDD							
Data packet length LSB							
Data packet type					Data packet length MSB		
Data Bytes							
Checksum							

The 3 bytes of the header are:

- ➔ the first byte (0xDD) used to identify the packet,
- ➔ the second byte represents the 8 LSB bits of the length of the data field,
- ➔ the last byte is made of 2 parts :
 - the 3 LSB bits represent the 3 MSB bits of the length of the data field,
 - the 5 MSB bits represent the packet type.

Data packets can have different values according to the type of packet:

- ➔ 0 – DATA packet : the packet contains the data to transmit on the radio link or received from the radio link,
- ➔ 1 – STATUS packet: the packet contains the status of SA, SB, X bits⁽¹⁾ and the break condition coding as follow :

SA	SB	X	BRK	RI	Spare	Spare	Spare
----	----	---	-----	----	-------	-------	-------

- the length of data for the status packet is always equal to 1,
- whenever a status changes (except break), all the status bits are included,
- these bits are off by default (and therefore the bits DTR and RTS), so it is necessary to send a status packet to the target at the beginning of the multiplexing to start the transmission,
- ➔ 2 – READY packet : the packet indicates that the target is ready to receive data :
 - no data are transmitted in this packet (so the length is null),
- ➔ 3 – BUSY packet : the packet indicates that the target is busy and can not receive data :
 - like the ready packet, no data are transmitted,

1 These status bits contain the V24 control information :

- SA contains DTR (signal CT108 – from terminal to IWF) and DSR (signal CT107 – from terminal to IWF),
- SB contains RTS (signal CT105 – from terminal to IWF) and DCD (signal CT109 – from IWF to terminal),
- X contains CTS (signal CT106).

For more information, refer to GSM 07.02

29th September 2004

→ other values : currently, these values are not used (reserved for future enhancement).

The checksum is calculated like the AT command packet checksum (addition of all the transmitted bytes including the header bytes).

19.13.4 Examples

19.13.4.1 AT command and its answer

When there is no encapsulation the AT command transmitted on the serial link is like this (in ASCII and hexadecimal):

AT\r\n ⇔ 0x41 0x54 0x0D 0x0A

and the answer is like this :

\r\nOK\r\n ⇔ 0x0D 0x0A 0x4F 0x4B 0x0D 0x0A

With the encapsulation in the serial link, the packet transmitted is (in hexadecimal) :

0xAA 0x04 0xE8 0x41 0x54 0x0D 0x0A 0x42

and the answer is like this :

0xAA 0x06 0xE8 0x0D 0x0A 0x4F 0x4B 0x0D 0x0A 0x60

19.13.4.2 Initialisation and Data packet

When the Multiplexing Mode is activated (+WMUX=1), the product sends 2 Data packets after the establishment of a DATA call (after the CONNECT xxxx message) : 1 READY Packet and 1 STATUS Packet. To set the different signals to the right value, it is necessary to send a STATUS packet to the product.

Here are some examples of STATUS packets :

0xDD 0x01 0x08 0x40 0x26 ⇔ bit RTS is on

to start a data call, all the bits should be on :

0xDD 0x01 0x08 0xC0 0xA6 ⇔ bits DTR and RTS are on

19.13.5 Restriction

The autobauding mode is not available when the Multiplexing Mode is activated : the serial link speed must be set to a fixed rate.

19.14 CPHS Information field

CPHS Information		
Signification	Data field	Bit Field
All information	0	None
CSP service activated and allocated	1	0
SST service activated and allocated	2	1
Mailbox Number service activated and allocated	3	2
Operator Name Shortform service activated and alloc.	4	3
Information Numbers service activated and allocated	5	4
RFU	6	5
RFU	7	6
RFU	8	7
Voice Message Waiting indicator for Line 1	9	8
Voice Message Waiting indicator for Line 2	10	9
Data Message Waiting indicator	11	10
Fax Message Waiting indicator	12	11
Call Forward Activated indicator for Line 1	13	12
Call Forward Activated indicator for Line 2	14	13
Call Forward Activated indicator for Data	15	14
Call Forward Activated indicator for Fax	16	15
Reserved	17	16
Reserved	18	17
Reserved	19	18
Reserved	20	19
Line 1 Mailbox Number available	21	20
Line 2 Mailbox Number available	22	21
Data Mailbox Number available	23	22
Fax Mailbox Number available	24	23
EF Mn Updatable	25	24

19.15 CSP constants**19.15.1 Service Group : Call Offering**

Service	External value
Call Forwarding Unconditional	1
Call Forwarding On User Busy	2
Call Forwarding on No Reply	3
Call Forwarding On User Not Reachable	4
Call Transfer	5

19.15.2 Service Group : Call Restriction

Service	External value
Barring of All Outgoing Calls	9
Barring of Outgoing International Calls	10
Barring of Outgoing International Calls except those directed to the Home PLMN country	11
Barring of All Incoming Calls when Roaming Outside the Home PLMN country	12
BIC roam	13

19.15.3 Service Group : Other Supplementary Services

Service	External value
Multi-Party Service	17
Closed User Group	18
Advice Of Charge	19
Preferential CUG	20
CUG Outgoing Access	21

29th September 2004

19.15.4 Service Group : Group Completion

Service	External value
Call Hold	25
Call Waiting	26
Completion of Call to Busy Subscriber	27
Restriction of the menus allowing use of user to user signalling	28

19.15.5 Service Group : Teleservices

Service	External value
Short Message – Mobile Terminated	33
Short Message – Mobile Originated	34
Short Message – Cell Broadcast	35
Restricts menu options for the ability to set reply path active on outgoing Short Messages	36
SMS Delivery Confirmation	37
Restriction of menus for SMS Protocol ID options	38
Validity Period, restriction of menus for SMS Validity period options	39

19.15.6 Service Group : CPHS Teleservices

Service	External value
Alternate Line Service	41

19.15.7 Service Group : CPHS Features

Service	External value
Reserved : SST in phase 1 CPHS	49

29th September 2004

19.15.8 Service Group : Number Identification

Service	External value
Calling Line Identification Presentation	57
Connected Line Identification Restriction	59
Connected Line Identification Presentation	60
Malicious Call Indicator	61
CLI per call mode – default block CLI – menu to send CLI	63
CLI per call mode – default send CLI – menu to block CLI	64

19.15.9 Service Group : Phase 2+ Services

Service	External value
Menus concerned with GPRS functionality	65
Menus concerned with High Speed Circuit Switched Data functionality	66
ASCI Voice Group call menus	67
ASCI Voice Broadcast service menus	68
Multi Subscriber profile menus	69
Multiple band : Restriction of menus allowing user to select a particular GSM 900/ 1800 or 1900 band	70

19.15.10 Service Group : Value Added Services

Service	External value
Restriction of menu options for manual PLMN selection	73
Restriction of menu options for Voice Mail or other similar menus	74
Restriction of menu options for the ability to send Short messages with type Paging	75
Restriction of menu options for the ability to send Short messages with type Email	76
Restriction of menu options for Fax calls	77
Restriction of menu options for Data calls	78
Restriction of menus allowing the user to change language	80

29th September 2004

19.15.11 Service Group : Information Numbers

Service	External value
The ME shall only present Information numbers to the user if this field is set to FF	81

Note :

External values not used in these tables are reserved for further use.

29th September 2004

20 APPENDIX A (informative)

This chapter gives illustrative examples of the general AT commands used for a communication. The presentation of commands and responses is as close as possible to what a user can see on its test monitor. Blank lines have been intentionally removed.

20.1 Examples with the PIN required

20.1.1 when the ME has to be powered ON.

```
AT+CMEE=1          Enable the report mobile equipment errors
    OK
AT+CREG=1          Report registration
    OK
AT+CPAS           Query ME Status
    +CPAS: 5      (ME is asleep)
    OK
AT+CFUN=1         Set ME to full functionality
    OK
AT+COPS=0         Ask for automatic operator selection and registration.
    +CME ERROR: 11      SIM PIN required.
AT+CPIN=1234      User entered a wrong PIN
    +CME ERROR: 16      Incorrect password.
AT+CPIN=0000
    OK              PIN Ok
AT+COPS=0         Ask for automatic operator selection and registration.
    OK
    +CREG:1        Registered on the network
AT+COPS=3,0       Select the long name alphanumeric format.
    OK
AT+COPS?          Get the operator name
    +COPS: 0,0,"I OMNITEL"
    OK
```

20.1.2 When the ME has already been powered on.

```
AT+CMEE=1          Enable the report mobile equipment errors
    OK
AT+CPAS           Get the ME Status
    +CPAS: 0        ME is ready to receive commands
    OK
AT+CPIN?          Is ME requiring a password?
```

29th September 2004

+CPIN: SIM PIN *Yes, SIM PIN required*
AT+CPIN=0000
OK *PIN Ok*

20.2 Examples where a voice call is originated.

20.2.1 When the ME is powered on and the SIM PIN has been entered.

AT+CMEE=1 *Enable the reporting of mobile equipment errors*
OK
AT+WIND=63 *Ask to display the general indications.*
OK
AT+CPIN? *Is ME requiring a password?*
+CPIN: READY *product is ready*
ATD0607103543; *Make a voice call*
+WIND: 5,1 *Indication of call*
+WIND: 2 *Remote party is ringing.*
OK *Call setup was successful*
Conversation...
ATH *Release the call*
OK

20.2.2 When a voice call is attempted from a phonebook :

ATD>"John Pamborn";
+CME ERROR: 22 *The "John Pamborn" entry is not found.*
ATD>"Joel Guerry";
+WIND: 5,1 *Indication of outgoing call.*
+WIND: 2 *Remote party is ringing.*
OK *Call setup was successful*
Conversation...
ATH *Release the call*
OK

20.3 Example with incoming calls

20.3.1 When the ME is powered on and the SIM PIN has been entered.

AT+CMEE=1 *Enable the report mobile equipment errors*
OK
AT+WIND=63 *Ask to display the general indications.*

29th September 2004

OK

AT+CLIP=1 *Enable the calling line identification presentation.*

OK

AT+CRC=1 *Enable extended format of incoming indication.*

OK

AT+CNUM *Query own number (voice number) or MSISDN.*

+CNUM: "Speech", "+33608971019", 145

OK

Call this number from another equipment.

+WIND: 5, 1 *Indication of call (Ring)*

+CRING: VOICE *Type of call is VOICE.*

+CLIP: "+33607103543", 145,,, "John Panborn" *Identification of the remote party.*

+CRING: VOICE

ATA *Answer the call.*

OK

...Conversation...

NO CARRIER *The call has been released by the remote party.*

+WIND: 6,1 *Indication of call release.*

20.4 Example of a call forwarding

20.4.1 When the ME is powered on and the SIM PIN has been entered.

AT+CMEE=1 *Enable the report mobile equipment errors*

OK

AT+CCFC=1,3,"0607492638" *Register to a call forwarding when ME is busy.*

OK

AT+CCFC=2,3,"0149293031",129 *Register to a call forwarding when it does answer.*

+CME ERROR: 30 *No network service*

AT+CCFC=1,2 *Interrogate*

+CCFC: 1,1,"+33607492638",145 *Call forwarding active for a voice call.*

AT+CCFC=1,4 *Delete call forwarding ME busy*

OK

20.5 Example of a multiparty call

When the ME is powered on and the SIM PIN has been entered.

AT+CMEE=1 *Enable the report mobile equipment errors*

OK

29th September 2004

AT+WIND=63 *Ask to display the general indications.*
OK

AT+CCWA=1,1 *Enable call waiting.*
OK

ATD>"John Panborn";
+WIND: 5,1 *Indication of call.*
+WIND: 2 *Remote party is ringing.*
OK *Call setup was successful*

...Conversation (call1)...
+WIND: 5,2 *Indication of another call.*
+CCWA: "+33595984834",145,"Dolores Claiborne" *Another call is waiting.*

AT+CHLD=2 *Put first call on hold and answer the second one.*
OK

...Conversation (call2)...
AT+CHLD=3 *Every call is part of a multiparty conversation.*
OK

AT+CHLD=11 *Release the first call (with John Panborn) and recover the second call (with Dolores Claiborne)*
...Conversation (call2)...
ATH *Release the second call.*

20.6 Examples about phonebooks

For each example illustrated in this section: the ME is supposed to have been powered on and the SIM PIN entered.

20.6.1 The whole phonebook of the ME is read

AT+CPBS=? *Query supported phonebook memories*
+CPBS: ("SM","FD","ON") *ADN, FDN, and MSISDN phonebooks supported.*
AT+CPBS="SM" *Select ADN phonebook.*
OK

AT+CPBR=? *Read the index range and the length of the elements.*
+CPBR: (1-80),20,14 *80 locations (from 1 to 80), max length of 20 for the phone number, 14 characters max for the text.*

AT+CPBR=1,80 *Read all entries (only the ones set are returned).*
+CPBR: 1,"0346572834",129,"Dolores Claiborne"
+CPBR: 2,"1284374523",129,"Thad Beaumont"
+CPBR: 3, "1243657845",129,"John Panborn"
OK

20.6.2 Erase or Write a phonebook entry

AT+CPBW=? *Get the phonebook type.*

29th September 2004

+CPBW: (1-80),20,(129,145),14 *80 locations, max length of 20 for the phone number, TON/NPI of 129 or 145 and 14 characters max for the text.*

AT+CPBW=3 *Erase location 3*

OK

AT+CPBW=3,"4356729012",129,"Carry" *Write at location 3.*

OK

AT+CPBR=1,80 *Read all entries (only the ones set are returned).*

+CPBR: 1,"0346572834",129,"Dolores Claiborne"

+CPBR: 2,"1284374523",129,"Thad Beaumont"

+CPBR: 3,"4356729012",129,"Carry"

OK

20.6.3 Find phonebook entries

AT+CPBF=? *Get the phonebook type.*

+CPBF: 20,14 *Max length of 20 for the phone number, 10 characters for the text.*

AT+CPBF="D" *Read entries starting with "D".*

+CPBF: 1,"0346572834",129,"Dolores Clairborne"

OK

AT+CPBF="W" *Read entries with "W".*

+CME ERROR: 22 *Entry not found.*

29th September 2004

20.7 Examples about short messages

20.7.1 Send a short message

AT+CNMI=0,1,1,1,0 *SMS-DELIVERs are directly stored, SMS-STATUS-REPORTs are displayed*

OK

AT+CSMP=17,169,0,0 *SMS-SUBMIT message with a validity period (one day)*

OK

AT+CMGF=1 " " *Text mode to send a Short Message*

OK

AT+CSCA="+33608080706" *Set Service Center Address to +33608080706*

OK

AT+CMGS=0601290800 *Send a SMS-SUBMIT to mobile phone*

Product sends a 4 characters sequence: 0x0D 0x0A 0x3E 0x20

This is the first text line *Edit first line and press carriage return (<CR>, 0x0D)*

This is the last text line *Edit last line and send message by pressing <ctrl-Z> (0x1A)*

+CMGS: 5 *Success: message reference 5 is returned from the SMS Service Center*

+CDS: 2,5,"0601290800",129,"99/05/01 14:15:10+04

" " " *Success: report of successful message delivery received*

20.7.2 Read short messages

AT+CMGF=1 *Text mode to read Short Messages*

AT+CMGL="ALL" *List all stored messages*

+CMGL: 1,"REC READ","+336290918",,"99/05/01 14:15:10+04"

I will be late *This is the first message*

+CMGL: 2,"REC UNREAD","+336290918",,"99/05/01 14:19:44+04"

Traffic jam on Broadway *This is the second message*

OK

AT+CMGR=1 " " *Read the first message*

+CMGR: "REC READ","+336290918",,"99/05/01 14:19:44+04"

OK

20.8 Examples about Fax class 2

The normal characters are DTE generated. The bold characters are modem generated.

29th September 2004

20.8.1 Send a fax class 2

AT+FCLASS=2 *Select fax class 2*
OK

AT+FLID="LocalFax"
OK

ATD0601234567 *Call establishment*
+FCON *Connection OK*
[+FCSI:"RemoteFax"]
+FDIS:0,3,0,2,0,0,0,0
OK

AT+FDT *Beginning of the data transfer*
+FDCS:0,3,0,2,0,0,0,0
CONNECT
<0x11h> *Send carrier*
First page data terminated by <0x10h><0x03h>
OK *Page transmitted*

AT+FET=0 *Send another page*
+FPTS:1 *First page acquitted*
OK

AT+FDT
CONNECT
<0x11h> *Send carrier*
Second page data terminated by <0x10h><0x03h>
OK *Page transmitted*

AT+FET=2 *No more page*
+FPTS:1 *First page acknowledged*
+FHNG:0 *Normal end of connection*
OK

29th September 2004

20.8.2 Receive a fax class 2

```
AT+FCR=1
      OK
AT+FLID="LocalFax"
      OK
      RING                               Incoming call
ATA                                     Answer
+FCON                                  Connection OK
      [+FTSI:"RemoteFax"]
      +FDCS:0,3,0,2,0,0,0,0
      OK
AT+FDR
      +FCFR
      +FDCS:0,3,0,2,0,0,0,0
      CONNECT
      <0x12h>                             Receive page carrier
      First page data terminated by
      <0x10h><0x03h>
      OK                                  Page received
+FPST:1                               First page acknowledged
+FET:0                                 To receive another page
      OK
AT+FDR
      +FDCS:0,3,0,2,0,0,0,0
      CONNECT
      <0x12h>                             Receive page carrier
      Second page data terminated by
      <0x10h><0x03h>
      OK                                  Page received
+FPST:1                               Second page acknowledged
+FET:2                                 No more page to receive
      OK
AT+FDR
      +FHNG:0                             Normal end of connection
      OK
```

20.9 +CSIM and +CRSM Examples

NOTE : if SIM answer is not specified in the following examples, it will mean that the answer will depend on the SIM content.

29th September 2004

20.9.1 DF GSM selection and then status

```
at+csim=14,"A0A40000027F20"  
+CSIM=4,"9F16"
```

```
at+csim=10,"A0F2000016"  
+CSIM=48,"..."
```

20.9.2 DF Telecom selection and then status

```
at+csim=14,"A0A40000027F10"  
+CSIM=4,"9F16"
```

```
at+csim=10,"A0F2000016"  
+CSIM=48,"..."
```

20.9.3 EF ADN selection and then status

DF Telecom selection is mandatory just before the following AT commands.

```
at+csim=14,"A0A40000026F3A"  
+CSIM=4,"9F0F"
```

```
at+csim=10,"A0C000000F"  
+CSIM=34,"..."
```

20.9.4 Status commands

Status – No File Id – without P1,P2, P3

```
at+crsm=242
```

Status – 6F3A (EF ADN) – without P1, P2, P3

```
at+crsm=242,28474
```

Status – 6F07 (EF IMSI) – without P1, P2, P3

```
at+crsm=242,28423
```

Status – 3F00 (MF) – without P1, P2, P3

```
at+crsm=242,16128
```

29th September 2004

Status - 7F10 (DF Telecom) - without P1, P2, P3
at+crsm=242,32528

Status - 7F20 (DF Gsm) - without P1, P2, P3
at+crsm=242,32544

20.9.5 Get Response commands

Get Response - (EF ADN) - without P1, P2, P3
at+crsm=192,28474

Get Response - (EF IMSI) - without P1, P2, P3
at+crsm=192, 28423

Get Response - (MF) - without P1, P2, P3
at+crsm=192,16128

Get Response - (DF Telecom) - without P1, P2, P3
at+crsm=192,32528

Get Response - (DF Gsm) - without P1, P2, P3
at+crsm=192,32544

Get Response - 6F07 (EF IMSI)
at+crsm=192, 28423,0,0,15

20.9.6 Read Record commands

Read Record - EF ADN (Pin Code validated)
at+crsm=178,28474,1,4,28

29th September 2004

21 APPENDIX B: Support of SIM ToolKit by the M.E.

TABLE 1 – Support of SIM Toolkit classes

This has been extracted from the GSM Technical specification 11.14.

Command description	Classes		
	1	2	3
CALL CONTROL		X	X
CELL BROADCAST DOWNLOAD		X	X
DISPLAY TEXT		X	X
EVENT DOWNLOAD			
- MT call			X
- Call connected			X
- Call disconnected			X
- Location status			X
- User activity			X
- Idle screen available			X
GET INKEY		X	X
GET INPUT		X	X
GET READER STATUS \$(MultipleCard)\$			Lc
MENU SELECTION		X	X
MO SHORT MESSAGE CONTROL			X
MORE TIME		X	X
PERFORM CARD APDU \$(MultipleCard)\$			Lc
PLAY TONE		X	X
POLLING OFF		X	X
POLL INTERVAL		X	X
POWER ON CARD \$(MultipleCard)\$			Lc
POWER OFF CARD \$(MultipleCard)\$			Lc
PROVIDE LOCAL INFORMATION		X	X
REFRESH	X	X	X
RUN AT COMMAND \$(AT\$)			Lc
SELECT ITEM		X	X
SEND SHORT MESSAGE		X	X
SEND SS		X	X
SEND USSD			X
SET UP CALL		X	X
SET UP EVENT LIST			X
SET UP IDLE MODE TEXT \$(IdleModeText)\$			X
SET UP MENU		X	X
SMS-PP DOWNLOAD	X	X	X
TIMER MANAGEMENT \$(Timer)\$			Lc
TIMER EXPIRATION \$(Timer)\$			Lc

29th September 2004

TABLE 2 - Compatibility between available Terminal Responses and Proactive Commands

Terminal Responses	Proactive commands											
	Setup Menu (0)	Display Text(1)	Get Inkey (2)	Get Input (3)	Setup Call (4)	Play Tone (5)	Select Item (6)	Refresh (7)	Send SS (8)	Send SMS (9)	Send USSD (10)	Setup event list (11)
Backward Move (95)		•	•	•			•					
Command beyond ME capabilities (96)	•	•	•	•	•	•	•	•	•	•	•	•
ME currently unable to process command (97)	•	•	•	•	•	•	•	•	•	•	•	•
No response from the user (98)		•	•	•			•					
SIM session terminated by the user (99)		•	•	•	•	•	•					

22 APPENDIX C: Structure of TERMINAL PROFILE

First byte (Download):

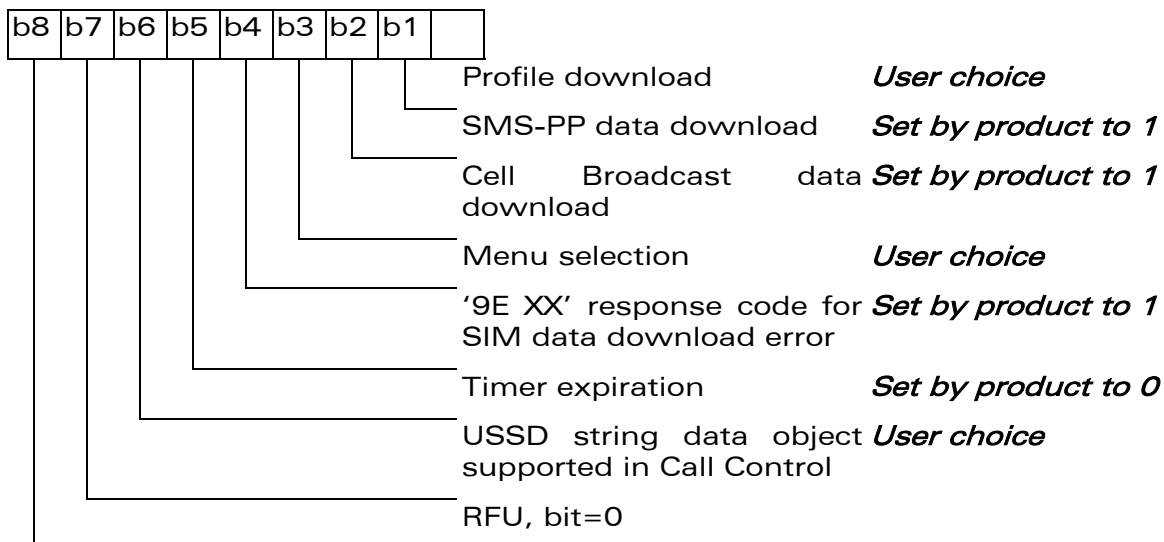

Second byte (Other):

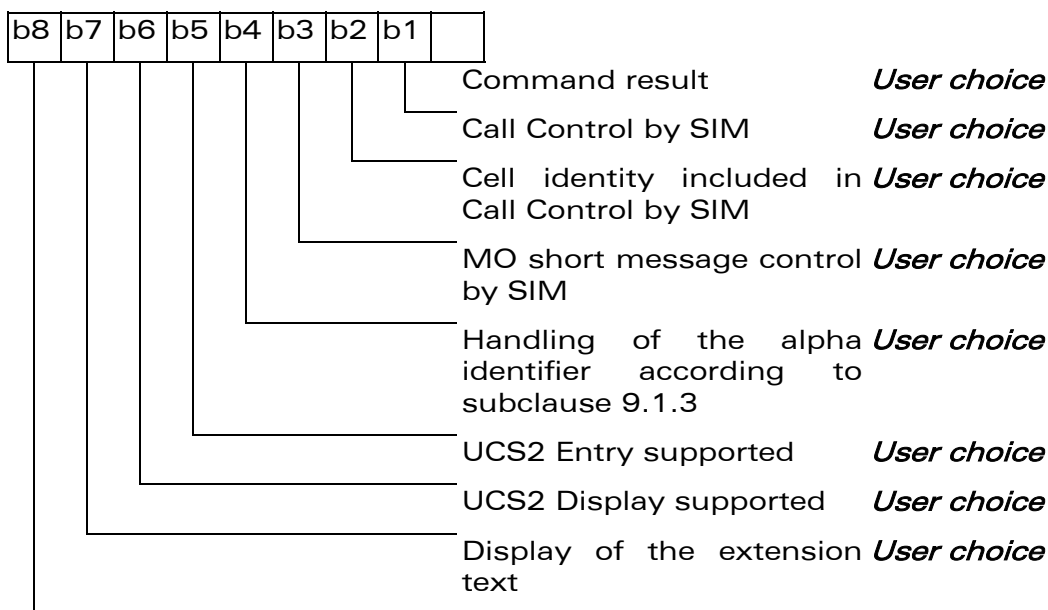

29th September 2004

Third byte (Proactive SIM):

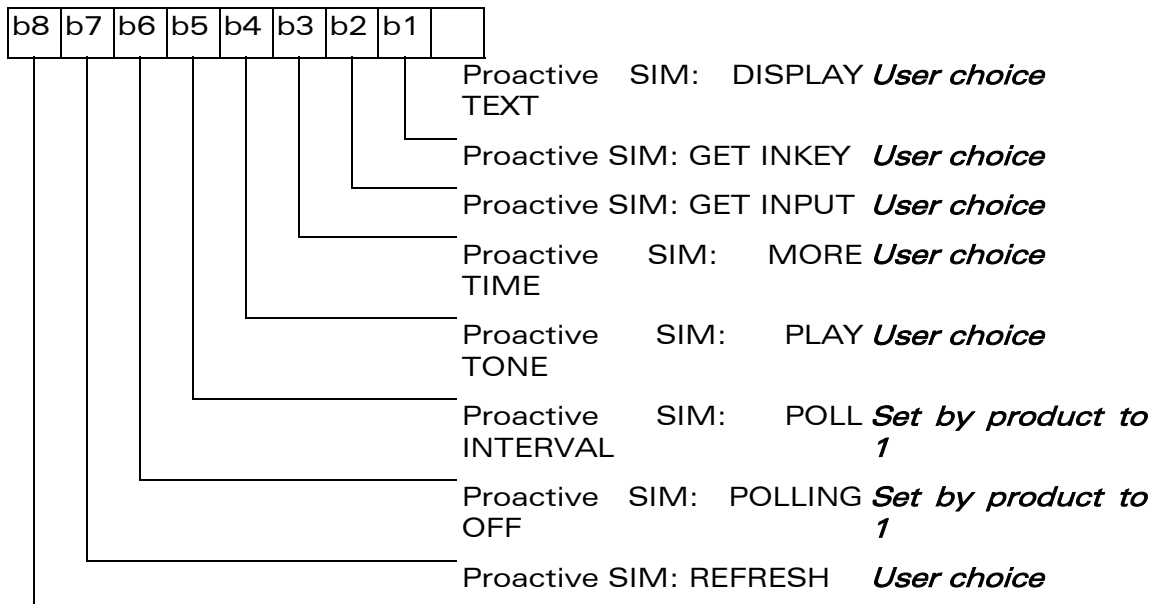

Fourth byte (Proactive SIM):

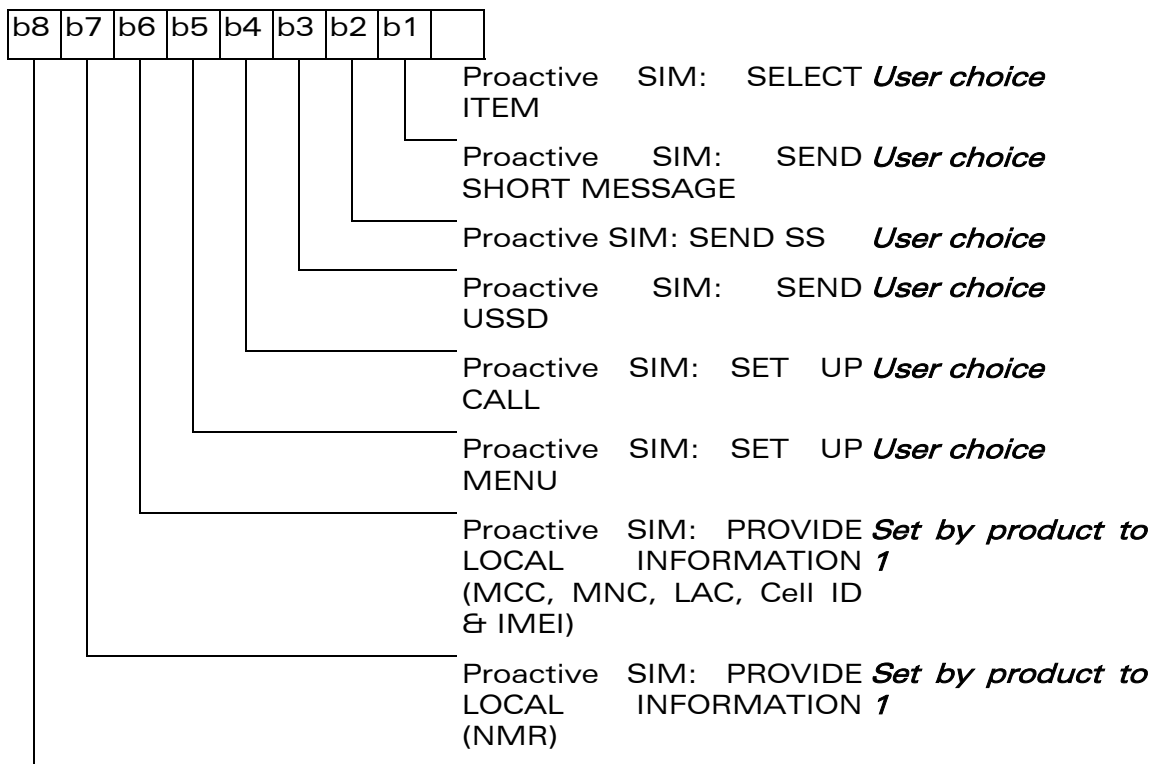

29th September 2004

Fifth byte (Event driven information):

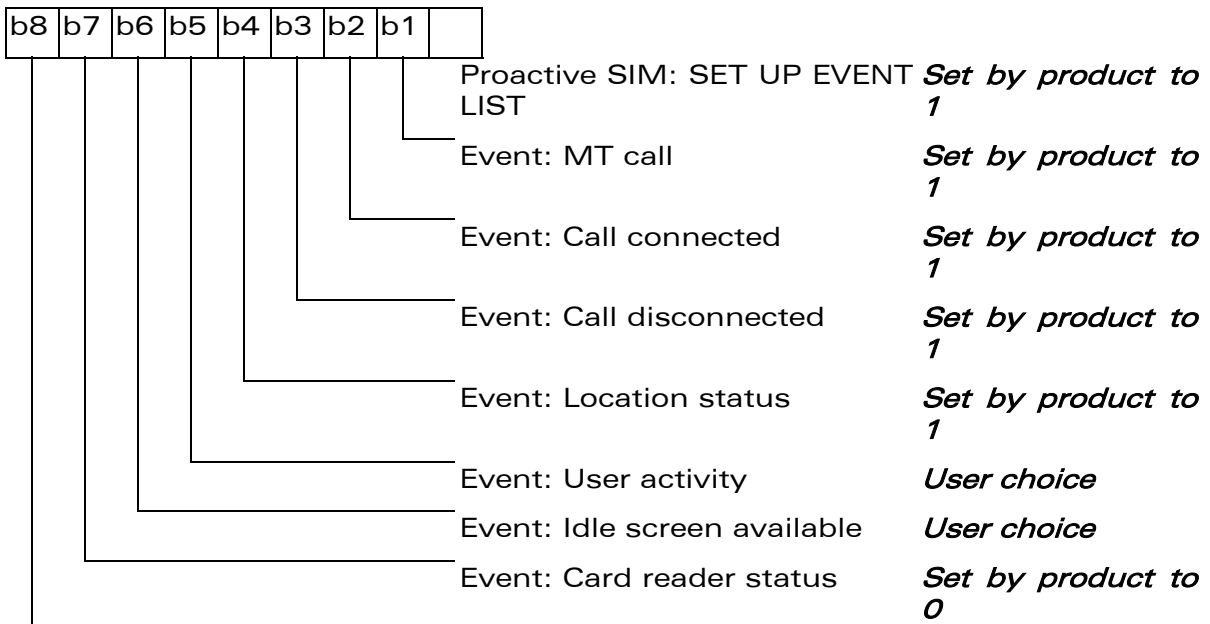

Sixth byte: (reserved for Event driven information extensions)

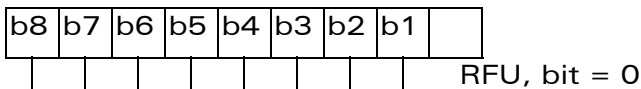

Seventh byte (Multiple card proactive commands) for class "a"

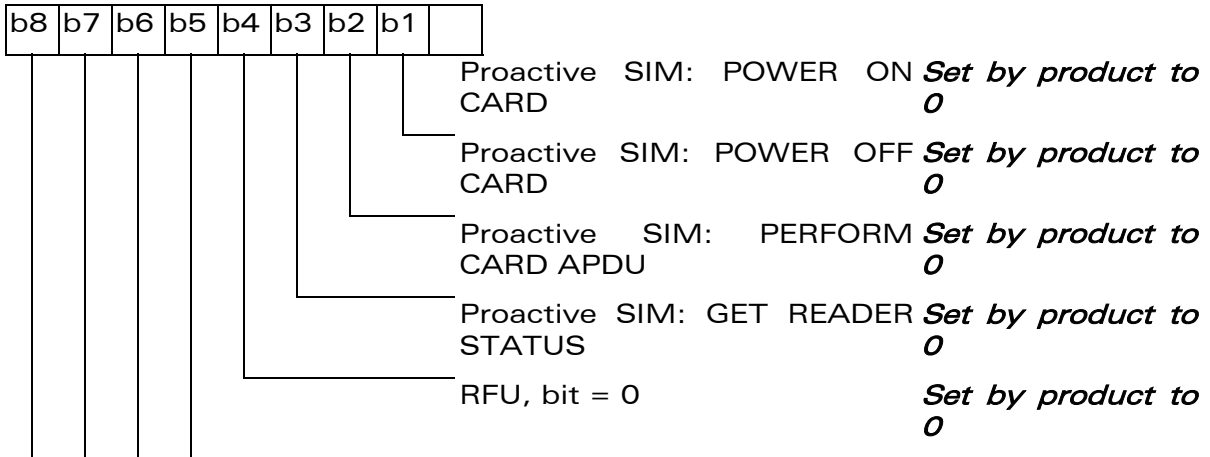

29th September 2004

Eighth byte (Proactive SIM):

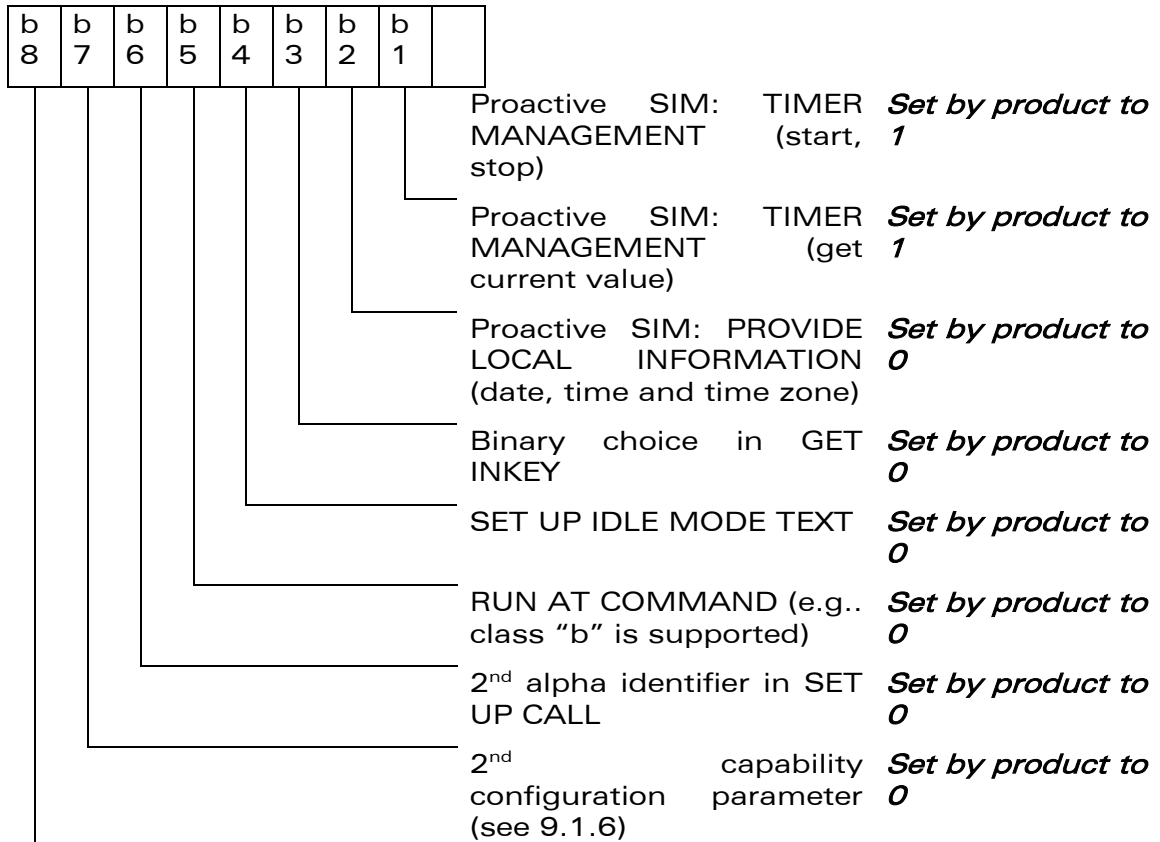

Ninth byte:

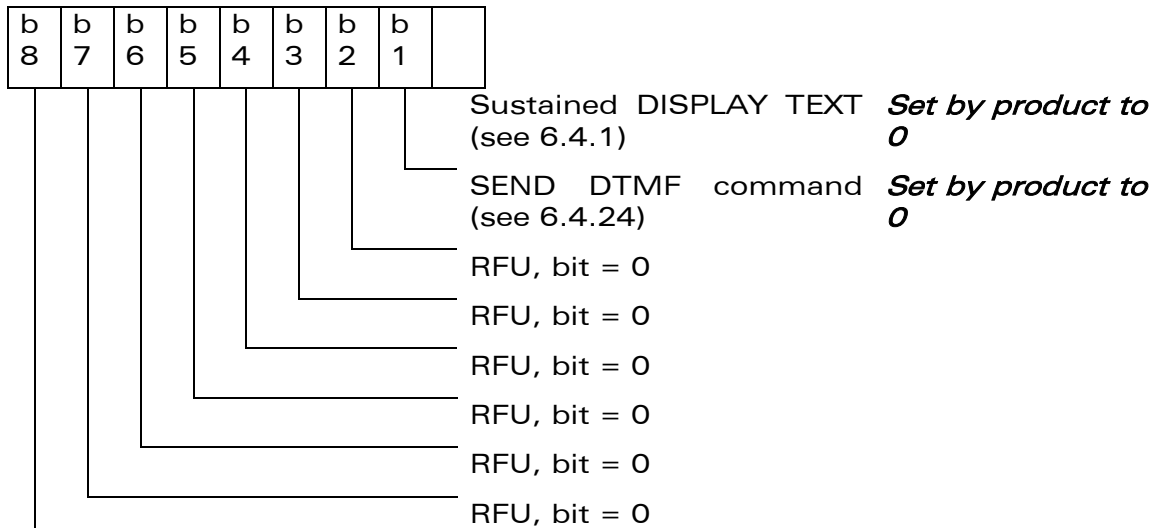

Subsequent bytes:

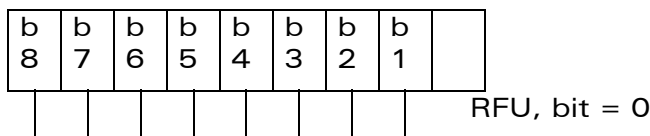

29th September 2004

Information about BCCH channel list

(this is an extract of GSM Rec 11.14)

Byte(s)	Description	Length
1	BCCH channel list tag	1
2	Length (X) of bytes following	1
3 to X+2	BCCH channel list	X

- BCCH channel list

Contents: the list of absolute RF channels for BCCH carriers, as known by the ME from the SYSTEM INFORMATION messages. The BCCH channel list is composed of one to three BCCH channel sub lists, each sub list is derived from the set of frequencies defined by reference neighbour cells description information element or elements. In the latter case the set is the union of the different subsets defined by the neighbour cells description information elements (see TS 04.08 [8]). The length of the BCCH channel list field depends on the length of the received BCCH channel list derived from the different SYSTEM INFORMATION messages to be considered.

Coding: Each ARFCN (*Absolute Radio Frequency Channel Number*) is represented by 10 bits. Spare bit(s) are to be filled with 0.

	Bit 8	Bit 7	Bit 6	Bit 5	Bit 4	Bit 3	Bit 2	Bit 1
Byte 1	ARFCN#1 (high part)							
Byte 2	ARFCN#1 (low part)			ARFCN#2 (high part)				
Byte 3	ARFCN#2 (low part)				ARFCN#3 (high part)			
...	...							
Byte X-1	ARFCN#m-1 (low part)				ARFCN#m (high part)			
Byte X	ARFCN#m (low part)						Spare bit (0)	Spare bit(0)

SIM applications should take into account that early implementations of SIM application toolkit may have coded this field differently, because of an inconsistency between the content and the coding of this element in previous versions of 11.14. The SIM is able to identify MEs that are using the coding described above by evaluating the indication "BCCH Channel List coding" in the TERMINAL PROFILE command.

29th September 2004

23 APPENDIX D: Command Type and Next Action Indicator.

This table has been extracted from the GSM Technical specification 11.14.

Value	Name	Used for Type of Command coding	used for Next Action Indicator coding
'00'		-	-
'01'	REFRESH	X	
'02'	MORE TIME	X	
'03'	POLL INTERVAL	X	
'04'	POLLING OFF	X	
'05'	SET UP EVENT LIST	X	
'10'	SET UP CALL	X	X
'11'	SEND SS	X	X
'12'	SEND USSD	X	X
'13'	SEND SHORT MESSAGE	X	X
'14'	SEND DTMF	X	
'20'	PLAY TONE	X	X
'21'	DISPLAY TEXT	X	X
'22'	GET INKEY	X	X
'23'	GET INPUT	X	X
'24'	SELECT ITEM	X	X
'25'	SET UP MENU	X	X
'26'	PROVIDE LOCAL INFORMATION	X	
'27'	TIMER MANAGEMENT	X	
'28'	SET UP IDLE MODEL TEXT	X	X
'30'	PERFORM CARD APDU	class "a" only X	X
'31'	POWER ON CARD	class "a" only X	X
'32'	POWER OFF CARD	class "a" only X	X
'33'	GET READER STATUS	class "a" only X	X
'34'	RUN AT COMMAND	class "b" only X	
'81'	End of the proactive session	not applicable	X

29th September 2004

24 APPENDIX E: Coding of Alpha fields in the SIM for UCS2

The coding can take one of the three following structures, or GSM default alphabet. If the ME supports UCS2 coding of alpha fields in the SIM, it will support all three coding schemes for character sets containing 128 characters or less. For character sets containing more than 128 characters, the ME will at least support the first coding scheme. Within a record, only one coding scheme, either GSM default alphabet, or one of the three described below, can be used.

1) If the **first byte in the alpha string is '0x80'**, then the other bytes are 16 bit UCS2 characters. The most significant byte (MSB) of the UCS2 character is coded in the lower numbered byte of the alpha field, and the less significant byte (LSB) of the UCS2 character is coded in the higher numbered alpha field byte. In other words, byte 2 of the alpha field contains the most significant byte (MSB) of the first UCS2 character, and byte 3 of the alpha field contains the less significant byte (LSB) of the first UCS2 character (as shown below). Unused bytes shall be set to 'FF' : if the alpha field has an even length in bytes, the last (unusable) byte will be set to 'FF'.

Example 1

Byte 1	Byte 2	Byte 3	Byte 4	Byte 5	Byte 6	Byte 7	Byte 8	Byte 9
'80'	Ch1 _{MSB}	Ch1 _{LSB}	Ch2 _{MSB}	Ch2 _{LSB}	Ch3 _{MSB}	Ch3 _{LSB}	'FF'	'FF'

2) If the **first byte of the alpha string is '0x81'**, then the 2nd byte contains a value indicating the number of characters in the string. The 3rd byte contains an 8 bit number which defines bits 15 to 8 of a 16 bit base pointer, where bit 16, and bits 7 to 1 would be set to zero. These sixteen bits represent a base pointer to a "half-page" in the UCS2 code space, to be used with some or all of the remaining bytes in the string. The 4th and subsequent bytes in the string contain codings as follows :

- if bit 8 of the byte is set to zero, the remaining bits of the byte contain a GSM Default Alphabet character
- if bit 8 of the byte is set to one, the remaining bits are an offset value to add to the 16 bit base pointer defined by byte 3, and the resulting 16 bit value is a UCS2 code point, and defines a UCS2 character.

Example 2

Byte 1	Byte 2	Byte 3	Byte 4	Byte 5	Byte 6	Byte 7	Byte 8	Byte 9
'81'	'05'	'13'	'53'	'95'	'A6'	'28'	'FF'	'FF'

In the example above;

- Byte 2 indicates there are 5 characters in the string
- Byte 3 indicates bits 15 to 8 of the base pointer, and indicates a bit pattern of 0hhh hhhh h000 0000 as the 16 bit base pointer number. Bengali characters for example start at code position 0980 (0000 1001 1000 0000), which is indicated by the coding '13' in byte 3 (shown by the italicised underlined digits).
- Byte 4 indicates GSM Default Alphabet character '53', e.g.. "S".
- Byte 5 indicates a UCS2 character offset to the base pointer of '15', expressed in binary as follows 001 0101, which, when added to the base pointer value results in a sixteen bit value of 0000 1001 1001 0101, e.g.. '0995', which is the Bengali letter KA.
- Byte 8 contains the value 'FF' : as the string length is 5, this a valid character in the string, where the bit pattern 111 1111 is added to the base pointer, yielding to a sixteen bit value of 0000 1001 1111 1111 for the UCS2 character (that is '09FF').
- Byte 9 contains the padding value 0xFF.

29th September 2004

3) If the first byte of the alpha string is set to '0x82', then the 2nd byte contains the length of the string (number of characters).

The 3rd and 4th bytes contain a 16 bit number which defines the complete 16 bit base pointer to a "half-page" in the UCS2 code space, for use with some or all of the remaining bytes in the string.

The 5th and subsequent bytes in the string contain coding as follows :

- if bit 8 of the byte is set to zero, the remaining seven bits of the byte contain a GSM Default Alphabet character,
- if bit 8 of the byte is set to one, the remaining seven bits are an offset value added to the base pointer defined in bytes 3 and 4, and the resulting 16 bit value is a UCS2 code point, and defines a UCS2 character.

Example 3

Byte 1	Byte 2	Byte 3	Byte 4	Byte 5	Byte 6	Byte 7	Byte 8	Byte 9
'82'	'05'	'05'	'30'	'2D'	'82'	'D3'	'2D'	'31'

In the example above :

- Byte 2 indicates there are 5 characters in the string
- Bytes 3 and 4 contain a 16 bit base pointer number of '0530', pointing to the first character of the Armenian character set.
- Byte 5 contains a GSM Default Alphabet character of '2D', which is a dash "-".
- Byte 6 contains a value '82', which indicates it is an offset of '02' added to the base pointer, resulting in a UCS2 character code of '0532', which represents Armenian character Capital BEN.
- Byte 7 contains a value 'D3', an offset of '53', which when added to the base pointer results in a UCS2 code point of '0583', representing Armenian Character small PIWR.

29th September 2004

25 APPENDIX F: Specification of Power Down Control via RS232

This appendix describes how to activate and deactivate the power down mode of the product via the RS232 serial link. Refer to +W32K to activate or deactivate the power down mode.

In this document, the term "DTE" refers to the customer device driving the product, which is referred to as the "DCE".

The terms referring to the RS232 signals and levels are used according to the V.24 and V.28 recommendations. Here are some points to remind :

- DTR is the circuit 108/2,
- TX is the circuit 103,
- RX is the circuit 102,
- CTS is the circuit 106.
- The logical level "HIGH or ON" corresponds to the electrical level of +12 V, and the level "LOW or OFF" corresponds to -12 V.
- The activation and deactivation are always initiated from the DTE and is carried out through the handshaking of DTR and CTS.

The power down mode can be triggered only when the DCE is idle, that means when there is no connection to the network in progress.

When the DTE requests the DCE to enter the power down mode, it (DTE) drops (ON-to-OFF transition) DTR. From this time on, it (DTE) **must not send** any more characters on the TX line : the TX FIFO must be empty.

The DCE acknowledges its entry in the power down mode by dropping CTS, within a time interval of 5s. after the DTR drop. During that period the DTE is prohibited from sending any more AT commands.

AT responses can be sent to the DTE even if the DCE is in power down mode : for this, it (DCE) suspends its power down mode, sends the requested AT response and recovers the power down mode. Therefore the DTE can trigger DCE power down mode without having to take care of any AT responses

The DCE exits the power down mode by raising the DTR. DCE is not ready to receive further AT commands until it raises in turn CTS, within a time interval of 2s. after the DTR raise.

29th September 2004

Here below is a diagram depicting the handshaking:

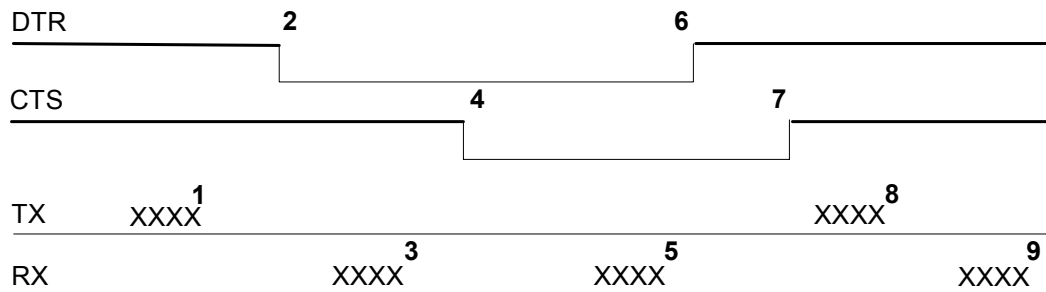

Description of the steps:

1: the DTE sends an AT command

2: the DTE drops DTR to make the DCE enter the power down mode. Warning: this mode will not really enter until CTS is dropped (step 4). The DTE could also have dropped DTR after having received the AT response (step 3).

3: the DCE sends back the AT response (if any)

4: the DCE drops CTS : it enters the power down mode.

5: the DCE sends back an unsolicited response (for instance a RING or +SMTI (incoming SMS indication))

6: the DTE wants to reply to that unsolicited response so it raises the DTR, causing the DCE to exit the power down mode.

7: the DCE acknowledges the exit of the power down mode by raising CTS.

8) & 9) exchange of AT commands/responses.

Note 1): The DTE must not send any AT commands from steps 2 to 7.

Note 2): During the latency period (between steps 2 and 4) should the DTE want to abort the power down mode, it raises DTR and should wait for 150µs before assessing CTS. If CTS is still high than the DCE has aborted the power down mode and is ready to receive AT commands.

The 150µs wait should get around the race condition between DTR raise and CTS drop.

Warning: The diagram above is V.28 compliant (PC interface), meaning the HIGH level corresponds to +12V, and the LOW level to -12V.

29th September 2004

26 APPENDIX G: Conditions for command execution and dependence to SIM

These arrays list all the AT command. For each, a column indicates the command execution condition (if +WIND:4 must have occurred OK, for example). SIM dependency column indicates if the command behaviour will vary if another card is used (for example, it will be the case for phonebook reading commands). The Intermediate column indicates if intermediate responses can occur for the considered command.

26.1 General commands

AT commands	Conditions	SIM dependence	Intermediate
AT+CGMI	None	N	N
AT+CGMM	None	N	N
AT+CGMR	None	N	N
AT+CGSN	None	N	N
AT+CSCS	+WIND: 4	N	N
AT+WPCS	+WIND: 4	N	N
AT+CIMI	+WIND: 4	Y	N
AT+CCID	+WIND: 1	Y	N
AT+GCAP	None	N	N
A/	Depends on previous command	Depends on prev. command	N
AT+CPOF	+WIND: 3 without SIM, +WIND: 1 with SIM	N	N
AT+CFUN	None	N	N
AT+CPAS	None	N	N
AT+CMEE	None	N	N
AT+CKPD	Depends of the sequence used	Y/N	N
AT+CCLK	+WIND: 4	Y	N
AT+CALA	None	N	Y
AT+CRMP	None	N	N
AT+CRSL	None	N	N

29th September 2004

26.2 Call Control commands

AT commands	Conditions	SIM dependence	Intermediate
ATD	Depends of sequence used	Y/N	Y
ATH	None	N	N
ATA	None	N	N
AT+CEER	+WIND: 4	Y	N
AT+VTD	None	N	N
AT+VTS	+WIND:5	N	N
ATDL	None	N	Y
AT%D	None	N	N
ATSO	None	N	N
AT+CICB	None	N	N
AT+CSNS	None	N	N
AT+VGR	None	N	N
AT+VGT	None	N	N
AT+CMUT	None	N	N
AT+SPEAKER	None	N	N
AT+ECHO	None	N	N
AT+SIDET	None	N	N
AT+VIP	None	N	N

26.3 Network service commands

AT commands	Conditions	SIM dependence	Intermediate
AT+CSQ	None	N	N
AT+COPS	+WIND: 4	Y	N
AT+CREG	None	N	Y
AT+WOPN	None	N	N
AT+CPLS	PIN	Y	N
AT+CPOL	+WIND: 7	Y	Y
AT+COPN	+WIND: 1	N	N

26.4 Security commands

AT commands	Conditions	SIM dependence	Intermediate
AT+CPIN	+WIND: 1	Y	N
AT+CPIN2	after PIN entered	Y	N
AT+CPINC	+WIND: 1	Y	N
AT+CLCK	+WIND: 4	Y	N
AT+CPWD	+WIND: 4	Y	N

26.5 Phonebook commands

AT commands	Conditions	SIM dependence	Intermediate
AT+CPBS	+WIND: 4	Y	N
AT+CPBR	+WIND: 4	Y	Y
AT+CPBF	+WIND : 4	Y	Y
AT+CPBW	+WIND: 4	Y	N
AT+CPBP	+WIND : 4	Y	Y
AT+CPBN	+WIND: 4	Y	Y
AT+CNUM	+WIND: 4	Y	N
AT+WAIP	None	N	N
AT+WDCP	+WIND: 4	Y	N
AT+CSVM	+WIND: 4	N	N

26.6 Short Messages commands

AT commands	Conditions	SIM dependence	Intermediate
AT+CSMS	+WIND: 4	Y	N
AT+CNMA	+WIND: 4	Y	N
AT+CPMS	+WIND: 4	Y	N
AT+CMGF	none	N	N
AT+CSAS		Y	N
AT+CRES		Y	N
AT+CSDH	+WIND: 4	Y	N
AT+CNMI	+WIND: 4	Y	N
AT+CMGR	+WIND : 4	Y	Y
AT+CMGL	+WIND: 4	Y	Y
AT+CMGS	+WIND: 4	Y	N
AT+CMGW	+WIND: 4	Y	Y

29th September 2004

AT commands	Conditions	SIM dependence	Intermediate
AT+CMMS	+WIND:4	Yes	No
AT+CMSS	+WIND: 4	Y	N
AT+CSMP	+WIND: 4	Y	N
AT+CMGD	+WIND: 4	Y	N
AT+CSCA		Y	N
AT+CSCB	+WIND: 4	Y	N
AT+WCBM	+WIND: 4	Y	N
AT+WMSC	+WIND : 4	Y	Y
AT+WMGO	+WIND: 4	Y	N
AT+WUSS	None	N	N

26.7 Supplementary Services commands

AT commands	Conditions	SIM dependence	Intermediate
AT+CCFC	+WIND: 4	Y	N
AT+CLCK	+WIND: 4	Y	N
AT+CPWD	+WIND: 4	Y	N
AT+CCWA	+WIND: 4	Y	N
AT+CLIR	+WIND: 4	Y	N
AT+CLIP	+WIND: 4	Y	N
AT+COLP	+WIND: 4	Y	N
AT+CAOC	+WIND: 4	Y	Y
AT+CACM	+WIND: 4	Y	N
AT+CAMM	+WIND: 4	Y	N
AT+CPUC	+WIND: 4	Y	N
AT+CHLD	+WIND: 4	Y	N
AT+CLCC	None	N	N
AT+CSSN	None	N	N
AT+CUSD	None	N	N
AT+CCUG	+WIND : 4	Y	Y

26.8 Data commands

AT commands	Conditions	SIM dependence	Intermediate
AT+CBST	None	N	N
AT+FCLASS	None	N	N
AT+CR	None	N	N
AT+CRC	None	N	N
AT+ILRR	+WIND: 4	N	N
AT+CRLP	None	N	N
AT+DOPT	None	N	N
AT%C	None	N	N
AT+DS	None	N	N
AT+DR	None	N	N
\N	None	N	N

26.9 Fax commands

AT commands	Conditions	SIM dependence	Intermediate
AT+FTM	None	N	N
AT+FRM	None	N	N
AT+FTH	None	N	N
AT+FRH	None	N	N
AT+FTS	None	N	N
AT+FRS	None	N	N

26.10 Class 2 Commands

AT commands	Conditions	SIM dependence	Intermediate
AT+FDT	None	N	N
AT+FDR	None	N	N
AT+FET	None	N	N
AT+FPTS	None	N	N
AT+FK	None	N	N
AT+FBOR	None	N	N
AT+FBUF	None	N	N
AT+FCQ	None	N	N
AT+FCR	None	N	N

29th September 2004

AT commands	Conditions	SIM dependence	Intermediate
AT+FDIS	None	N	N
AT+FDCC	None	N	N
AT+FLID	None	N	N
AT+FPHCTO	None	N	N

26.11 V24-V25 commands

AT commands	Conditions	SIM dependence	Intermediate
AT+IPR	None	N	N
AT+ICF	None	N	N
AT+IFC	None	N	N
AT&C	None	N	N
AT&D	None	N	N
AT&S	None	N	N
ATO	+WIND: 4	N	N
ATQ	None	N	N
ATV	None	N	N
ATZ	None	N	N
AT&W	None	N	N
AT&T	None	N	N
ATE	None	N	N
AT&F	None	N	N
AT&V	None	N	N
ATI	None	N	N
AT+WMUX	None	N	N

26.12 Specific AT commands

AT commands	Conditions	SIM dependence	Intermediate
AT+CCED	None	N	N
AT+WIND	None	N	N
AT+ADC	None	N	N
AT+CMER	None	N	N
AT+CIND	None	N	N
AT+CMEC	None	N	N
AT+WLPR	+WIND: 1	N	N
AT+WLPW	+WIND: 1	N	N
AT+WIOR	None	N	N
AT+WIOW	None	N	N
AT+WIOM	None	N	N
AT+WAC	None	N	N
AT+WTONE	None	N	N
AT+WDTMF	None	N	N
AT+WDWL	None	N	N
AT+WVR	None	N	N
AT+WDR	None	N	N
AT+WHWV	None	N	N
AT+WDOP	None	N	N
AT+WSVG	None	N	N
AT+WSTR	None	N	N
AT+WSCAN	None	N	N
AT+WRIM	None	N	N
AT+W32K	None	N	N
AT+WCDM	None	N	N
AT+WSSW	None	N	N
AT+WCCS	+WIND: 4	N	N
AT+WLCK	None (PIN for auto CNL)	N (Y for auto CNL)	N
AT+CPHS	+WIND: 4	Y	N
AT+WBCM	None	N	N
AT+WFM	None	N	N
AT+WCFM	None	N	N
AT+WMIR	None	N	N
AT+WCDP	None	N	N
AT+WMBN	PIN	Y	N
AT+WALS	+WIND:4	Y	N

29th September 2004

AT commands	Conditions	SIM dependence	Intermediate
AT+WOPEN	None	N	N
AT+WRST	None	N	N
AT+WSST	None	N	N
AT+WLOC	PIN Code	Y	N
AT+WBR	None	N	N
AT+WBW	None	N	N
AT+WBM	None	N	N
AT+WATH	None	N	N
AT+WIMEI	None	N	N
AT+WSVN	None	N	N
AT+WMBS	None	N	N
AT+WMBS	None	Y	N
AT+WBHV	None	N	N

26.13 SIM Toolkit commands

AT commands	Conditions	SIM dependence	Intermediate
AT+STSF	None	N	N
AT+STIN	+WIND: 4	Y	N
AT+STGI	+WIND: 4	Y	N
AT+STGR	+WIND: 4	Y	N

26.14 GPRS commands

AT commands	Conditions	SIM dependence	Intermediate
AT+CGDCONT	+WIND:4		
AT+CGQREQ	+WIND:4		
AT+CGQMIN	+WIND:4		
AT+CGATT	+WIND:4		
AT+CGACT	+WIND:4		
AT+CGDATA	+WIND:4		
AT+CGCLASS	+WIND:3	N	N
AT+CGCLASS	+WIND:4		
AT+CGSMS	+WIND:4		
AT+CGREP	+WIND:4		
AT+CGREG	+WIND:4		
AT+CGAUTO	+WIND:4		

29th September 2004

AT commands	Conditions	SIM dependence	Intermediate
AT+CGANS	+WIND:4		
AT+CGADDR	+WIND:4		
AT+WGPRS	+WIND:4		

29th September 2004

27 APPENDIX H: Interoperability commands always reply OK

All the commands listed below are only used for interoperability with other applications. They have no action and always reply OK.

Command	Responses
ATB	OK
ATC	OK
ATG	OK
ATL	OK
ATM	OK
ATN	OK
ATP	OK
ATT	OK
ATW	OK
ATX	OK
ATY	OK
ATK	OK
AT&E	OK
AT&G	OK
AT&K	OK
AT&P	OK
AT&Q	OK
AT&R	OK
AT&Y	OK
AT+GOI	OK
AT+GCI	OK

28 Alphabetical Index for AT commands and responses

AT command / response	Type of Command	Paragraph Nb
\N	Data	11.12
%C	Data	11.9
%D	Call Control	5.8
&C	V24-V25	14.4
&D	V24-V25	14.5
&F	V24-V25	14.14
&S	V24-V25	14.6
&T	V24-V25	14.12
&V	V24-V25	14.15
&W	V24-V25	14.11
+ADC	Specific	15.3
+CACM	Supplementary services	10.9
+CALA	General	4.17
+CAMM	Supplementary services	10.10
+CAOC	Supplementary services	10.8
+CBST	Data	11.2
+CCED	Specific	15.1
+CCFC	Supplementary services	10.1
+CCID	General	4.8
+CCLK	General	4.16
+CCUG	Supplementary services	10.16
+CCWA	Supplementary services	10.4
+CEER	Call Control, GPRS	5.5, 17.18
+CIEV	Specific	15.4
+CFUN	General	4.12
+CGACT	GPRS	17.5
+CGANS	GPRS	17.14
+CGATT	GPRS	17.4
+CGAUTO	GPRS	17.13
+CGCLASS	GPRS	17.7
+CGDATA	GPRS	17.6
+CGDCONT	GPRS	17.1
+CGEREP	GPRS	17.9

29th September 2004

AT command / response	Type of Command	Paragraph Nb
+CGMI	General	4.1
+CGMM	General	4.2
+CGMR	General	4.3
+CGPADDR	GPRS	17.15
+CGQMIN	GPRS	17.3
+CGQREQ	GPRS	17.2
+CGREG	GPRS	17.10
+CGSMS	GPRS	17.8
+CGSN	General	4.4
+CHLD	Supplementary services	10.12
+CICB	Call Control	5.10
+CIMI	General	4.7
+CIND	Specific	15.5
+CKEV	Specific	15.4
+CKPD	General	4.15
+CLCC	Supplementary services	10.13
+CLCK	Security, Supplementary services	7.4, 10.2
+CLIP	Supplementary services	10.6
+CLIR	Supplementary services	10.5
+CMEC	Specific	15.7
+CMEE	General	4.14
+CMER	Specific	15.4
+CMGD	Short Messages	9.16
+CMGF	Short Messages	9.5
+CMGL	Short Messages	9.11
+CMGR	Short Messages	9.10
+CMGS	Short Messages	9.12
+CMGW	Short Messages	9.13
+CMSS	Short Messages	9.14
+CMUT	Call Control	5.13
+CNMA	Short Messages	9.3
+CNMI	Short Messages	9.9
+CNUM	Phonebook	8.7
+COLP	Supplementary services	10.7
+COPN	Network services	6.7
+COPS	Network services	6.2

29th September 2004

AT command / response	Type of Command	Paragraph Nb
+CPAS	General	4.13
+CPBF	Phonebook	8.3
+CPBN	Phonebook	8.6
+CPBP	Phonebook	8.5
+CPBR	Phonebook	8.2
+CPBS	Phonebook	8.1
+CPBW	Phonebook	8.4
+CPHS	Specific	15.29
+CPIN	Security	7.1
+CPIN2	Security	7.2
+CPINC	Security	7.3
+CPLS	Network services	6.5
+CPMS	Short Messages	9.4
+CPOF	General	4.11
+CPOL	Network services	6.6
+CPUC	Supplementary services	10.11
+CPWD	Security	7.5
	Supplementary services	10.3
+CR	Data	11.4
	GPRS	17.17
+CRC	Data	11.5
	GPRS	17.16
+CREG	Network services	6.3
+CRES	Short Messages	9.7
+CRLP	Data	11.7
+CRMP	General	4.18
+CRSL	General	4.19
+CRSM	General (RIL)	4.21
+CSAS	Short Messages	9.6
+CSCA	Short Messages	9.17
+CSCB	Short Messages	9.18
+CSCS	General	4.5
+CSDH	Short Messages	9.8
+CSIM	General (RIL)	4.20
+CSMP	Short Messages	9.15
+CSMS	Short Messages	9.2
+CSNS	Call Control	5.11

29th September 2004

AT command / response	Type of Command	Paragraph Nb
+CSQ	Network services	6.1
+CSSN	Supplementary services	10.14
+CSVM	Phonebook	8.10
+CUSD	Supplementary services	10.15
+DOPT	Data	11.8
+DR	Data	11.11
+DS	Data	11.10
+ECHO	Call Control	5.15
+FBOR	Class 2	13.6
+FBUF	Class 2	13.7
+FCLASS	Data	11.3
+FCFR	Class 2	13.14
+FCON	Class 2	13.14
+FCQ	Class 2	13.8
+FCR	Class 2	13.9
+FCSI	Class 2	13.14
+FDCC	Class 2	13.11
+FDCS	Class 2	13.14
+FDIS	Class 2	13.10, 13.14
+FDR	Class 2	13.2
+FDT	Class 2	13.1
+FET	Class 2	13.3, 13.14
+FHNG	Class 2	13.14
+FPTS	Class 2	13.4, 13.14
+FTSI	Class 2	13.14
+FK	Class 2	13.5
+FLID	Class 2	13.12
+FPHCTO	Class 2	13.13
+FRH	Fax	12.4
+FRM	Fax	12.2
+FRS	Fax	12.6
+FTH	Fax	12.3
+FTM	Fax	12.1
+FTS	Fax	12.5
+GCAP	General	4.9
+ICF	V24-V25	14.2
+IFC	V24-V25	14.3

29th September 2004

AT command / response	Type of Command	Paragraph Nb
+ILRR	Data	11.6
+IPR	V24-V25	14.1
+SIDET	Call Control	5.16
+SPEAKER	Call Control	5.14
+STCR	SIM toolkit (unsolicited.response)	16.3.4
+STGI	SIM Toolkit	16.3.3
+STGR	SIM Toolkit	16.3.5
+STIN	SIM Toolkit	16.3.2
+STSF	SIM Toolkit	16.3.1
+VGR	Call Control	5.12
+VGT	Call Control	5.12
+VIP	Call Control	5.17
+VTD	Call Control	5.6
+VTS	Call Control	5.6
+W32K	Specific	15.24
+WAC	Specific	15.12
+WAIP	Phonebook	8.8
+WALS	Specific	15.42
+WATH	Specific	15.50
+WBCI	Specific	15.36
+WBCM	Specific	15.35
+WBHV	Specific	15.56
+WBM	Specific	15.49
+WBR	Specific	15.47
+WBW	Specific	15.48
+WCCS	Specific	15.27
+WCBM	Short Messages	9.19
+WCDM	Specific	15.25
+WCDP	Specific	15.40
+WCFM	Specific	15.38
+WCPI	Specific	15.33
+WCSP	Specific	15.34
+WCTM	Specific	15.55
+WDCI	Specific	15.31
+WDCP	Phonebook	8.9
+WDOP	Specific	15.19

29th September 2004

AT command / response	Type of Command	Paragraph Nb
+WDR	Specific	15.17
+WDTMF	Specific	15.14
+WDWL	Specific	15.15
+WFM	Specific	15.37
+WGPRS	GPRS	17.19
+WHCNF	Specific	15.57
+WHWV	Specific	15.18
+WIMEI	Specific	15.51
+WIND	Specific	15.2
+WIOM	Specific	15.11
+WIOR	Specific	15.9
+WIOW	Specific	15.10
+WLCK	Specific	15.28
+WLOC	Specific	15.46
+WLPR	Specific	15.7
+WLPW	Specific	15.8
+WMBN	Specific	15.41
+WMBS	Specific	15.53
+WMGO	Short Messages	9.21
+WMIR	Specific	15.39
+WMSC	Short Messages	9.20
+WMSN	Specific	15.54
+WMUX	V24-V25	14.17
+WNON	Specific	15.32
+WOPEN	Specific	15.43
+WOPN	Network services	6.4
+WPCS	General	4.6
+WRIM	Specific	15.23
+WRST	Specific	15.44
+WSCAN	Specific	15.22
+WSST	Specific	15.45
+WSSW	Specific	15.26
+WSTR	Specific	15.21
+WSVG	Specific	15.20
+WSVN	Specific	15.52
+WTONE	Specific	15.13
+WUSS	Short Messages	9.22

29th September 2004

AT command / response	Type of Command	Paragraph Nb
+WVMI	Specific	15.30
+WVR	Specific	15.16
A	Call Control GPRS	5.3 17.12.2
A/	General	4.10
D	Call Control GPRS	5.1 17.11
DL	Call Control	5.7
E	V24-V25	14.13
H	Call Control GPRS	5.2 17.12.3
I	V24-V25	14.16
O	V24-V25	14.7
Q	V24-V25	14.8
S0	Call Control GPRS	5.9 17.12.1
V	V24-V25	14.9
Z	V24-V25	14.10